



XCT8 VRF System

More than a century of cool

In 1902, a determined engineer answered one of mankind's most nagging questions: How do we make hot, sticky, indoor air go away? In creating the world's first modern air conditioning system, Willis Carrier forever changed indoor life, and, more than a century later, the corporation that bears his name takes inspiration from his example.

Carrier strives to improve on our founder's breakthroughs, introducing new technologies that make life at home even cooler. Today, a nationwide network of experts continues to advance Willis Carrier's lifework. Your expert Carrier dealer is equipped to evaluate your home and create a customized system designed around your lifestyle.



Choose Carrier
XCT8 VRF systems
for Flexibility,
Efficiency
& Performance



carrier.com 1-C-VRF-011323-EN-1-SEA

©2025 Carrier. All Rights Reserved.

Manufacturer reserves the right to discontinue, or change at any time, specifications or designs without notice or without incurring obligations. Third-party trademarks and logos are the property of their respective owners.



Content ▶

Our Legacy	01
VRF System.....	05
Outdoor Unit	09
• Top-discharge VRF	
• Side-discharge Mini VRF	
• Modular Side-discharge VRF	
Indoor Unit	53
• High-Wall	
• 1-Way Cassette	
• 2-Way Cassette	
• Compact Cassette	
• Round Way Cassette	
• Floor-Ceiling	
• Low Static Duct	
• Medium Static Duct	
• Free Static Duct	
• High Static Duct	
• Vertical Duct	
• Fresh Air Processor	
Controller	102
• Individual Controller	
• Central Controller	
• Network Central Controller	
• BMS Gateway	
Accessories	114
• AHU Kit	
• Pipe Connection Accessories	

Carrier's Heritage: The Invention that Changed the World

On July 17, 1902, Willis Carrier designed the modern air-conditioning system to solve a production problem at the Sackett & Wilhelms printing plant in Brooklyn, New York, launching an industry that would fundamentally improve the way we live, work and play.



Willis Carrier changed the world in 1902 when he designed the first modern air-conditioning system.

1902

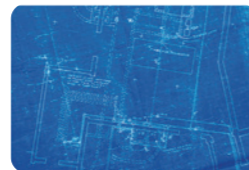

Carrier hires America's first female air-conditioning engineer right around the time the decision to allow American women to vote was being debated by lawmakers.

1917

1911

Willis Carrier's Rational Psychrometric Formulae brought science to what had previously been the often hit-or-miss design of air-conditioning systems, and in the process made Carrier an international name.

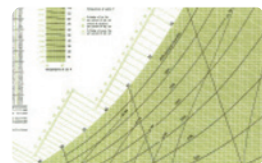

1922

Carrier unveiled the first centrifugal chiller which opened the door to large-scale comfort air-conditioning.

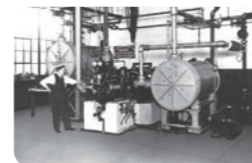

1931

The M.V. Victoria became the first vessel to make its maiden voyage equipped with Carrier air conditioning.



2021

Launch of XCT7 Carrier VRF in Southeast Asia.



Carrier introduces the first home air conditioner.

1926

Willis Carrier is named among Time magazine's 100 Most influential People of the Century.

1998

Launch of XCT8 Carrier VRF in Southeast Asia.



2025



Our Company

Carrier Global Corporation, global leader in intelligent climate and energy solutions, is committed to creating solutions that matter for people and our planet for generations to come. From the beginning, we've led in inventing new technologies and entirely new industries. Today, we continue to lead because we have a world-class, diverse workforce that puts the customer at the center of everything we do.



~48,000

Employees



80+

New products
launched in 2024



\$22.5B

Net sales in 2024



~160

Countries

Innovation

A Leading Legacy

Carrier was built on a legacy of innovation, beginning with our founders. We are innovators at heart and inventors by heritage. Right from the start, we've pioneered new technologies and enabled entirely new industries that have changed the world. Today, building on our legacy of innovations, we're boldly advancing the industries we created to make a difference in people's lives.

Innovating Everywhere

Our industry-leading solutions and services are keeping buildings and homes across the globe comfortable, safe, and secure.



Understanding VRF Systems

Setting the standard for flexibility, efficiency & performance

Variable Refrigerant Flow (VRF) systems are large-scale ductless HVAC systems performing at high capacity. VRF technology has the unmatched ability for multiple indoor units or zones to operate on the same outdoor system.

It is a multi-outdoor-unit solution that carefully computes the precise amount of refrigerant required by each indoor unit to achieve individualized temperature control for each comfort zone.

Because of its flexibility, VRF systems can be customized to meet the specific demands of any project. It controls the refrigerant flow according to the heat load requirement to avoid over cooling or heating effectively.

Why Choose VRF Systems?

Your choice makes a difference. When you invest in Carrier VRF, you create a system that delivers on the promises of comfort, performance, and reliability - the backbone of the Carrier confidence.



Flexibility

Whether you're looking to maximize comfort in a new building or retrofit an existing one, VRF systems join design flexibility with potential energy savings.



Efficiency

VRF systems use minimal ductwork, and sometimes, none at all (depending on the application). This makes installation and maintenance far easier, and also precisely matches power requirement for improved efficiency.



Performance

System performance is significantly enhanced because of the heat transfer properties of refrigerant over other mediums, while the zone temperature control brings ideal comfort.

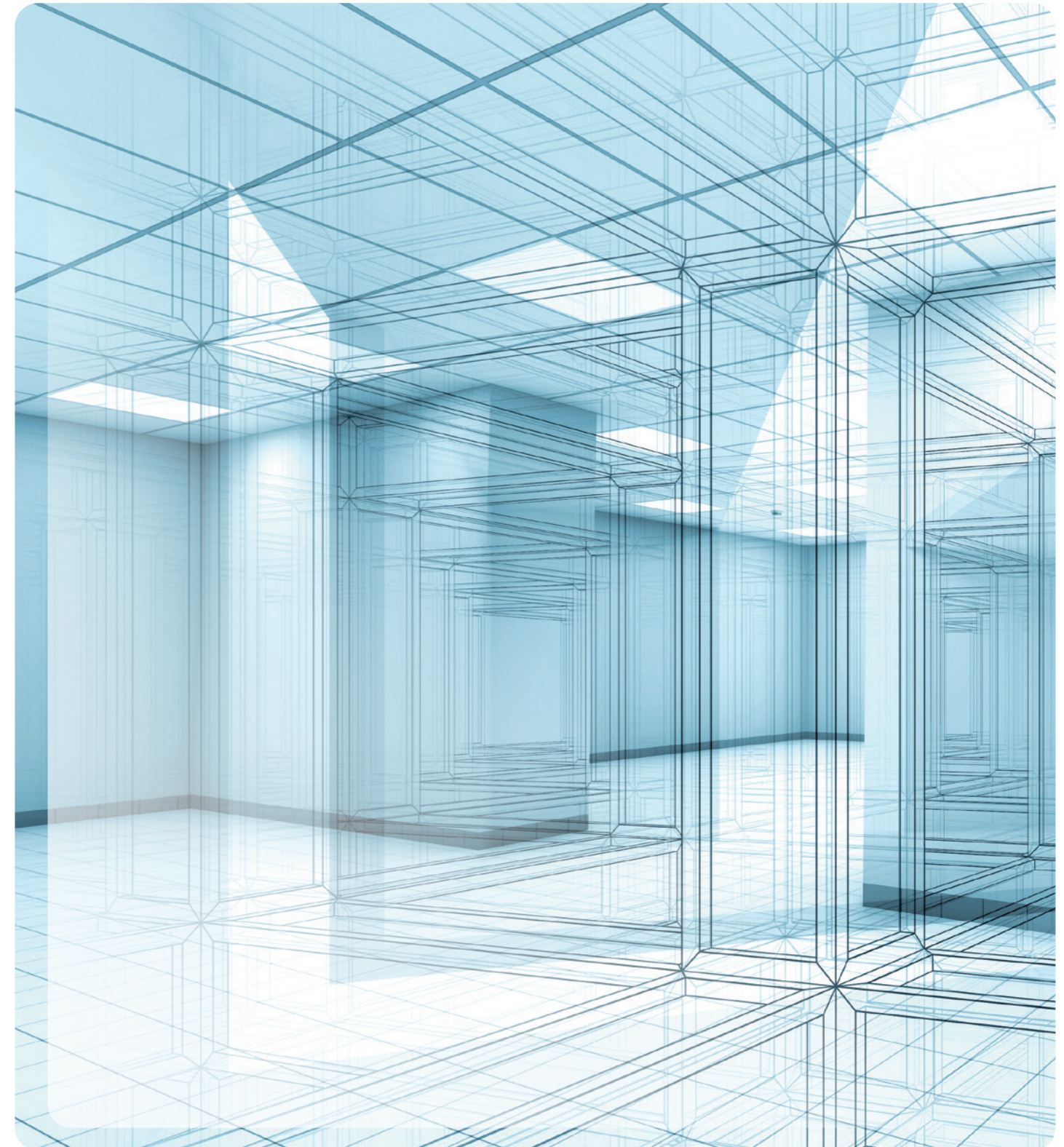

Why Choose Carrier VRF?

Your choice makes a difference. When you invest in Carrier VRF, you create a system that delivers on the promises of comfort, performance, and reliability-the backbone of the Carrier confidence.

High efficiency

- Advanced DC Twin-rotary compressor.
- Large-diameter DC Fan.
- Golden fin heat exchanger.

Ultimate reliability

- The rotation operation of outdoor module balances the life span of each module, which also extend the life span of whole system.
- Multi-layer oil return technology: 6-stage oil return technology for smooth lubrication.
- Multiple temperature and pressure sensors continuously monitor the system operating conditions to ensure optimal performance.

Incredible flexibility

- Piping design: up to 110m height difference for high rise buildings
- High static pressure: Outdoor unit achieves up to 85 Pa

Easy installation

- All-Units-On Operation automatically activates all indoor units simultaneously, reducing testing and commissioning time.
- Doctor Kit monitors the system data in real time with full control of indoor unit operations, enables quicker and easier testing and commissioning.

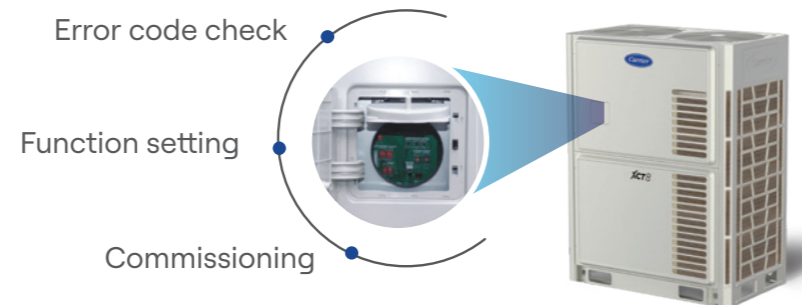
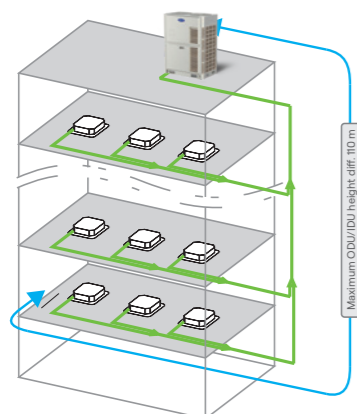

Enhanced user comfort

- The intelligent defrost effectively prolongs the normal heating time, improves comfort, and achieves energy-saving.
- Evaporation /Condensation temperature adaptive technology reduce the indoor temperature fluctuations for improving comfort.



Large operating range

- Heating operation at minimum -15°C.*
- Cooling operation at maximum +55°C.
- Refrigerant cooled PCB enables stable operation at high outdoor temperature.

* : For Top-discharge 380V HP



Wide range of options

- Outdoor Units: Large capacity top-discharge VRF up to 32HP single module, and new modular side-discharge VRF up to 24HP single module.
- Complete range of indoor units and AHU DX Kit
- User friendly control solutions.
- Up to 100 indoor units per system.



Enhanced system performance

- Power Saving Mode enables energy saving by limiting power consumption of outdoor unit from 100% to 40% in 7 steps.
- Activate the subsequent outdoor unit module when the capacity demand exceeds 85% capacity of the outdoor unit in operation - optimising cooling and efficiency performance.

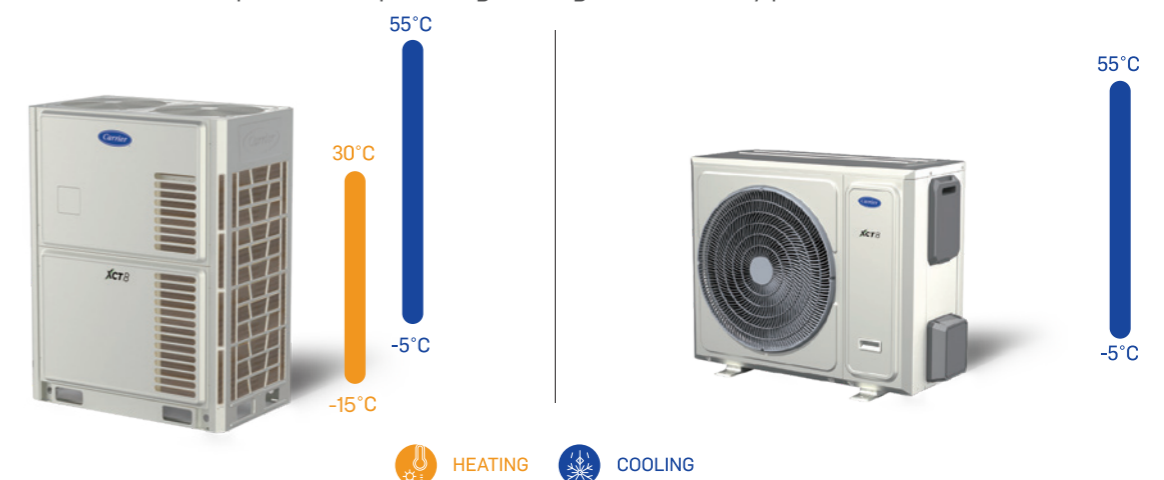

Top-discharge VRF

Outdoor Units Lineup



Heat Pump Series



8/10/12HP 14HP 16/18/20HP 22HP 24HP 26/28/30HP

Capacity (HP)	8	10	12	14	16	18	20	22	24	26	28	30
Power supply	380~415V/50Hz/3Ph, 380~415V/60Hz/3Ph											
8	•											
10		•										
12			•									
14				•								
16					•							
18						•						
20							•					
22								•				
24									•			
26										•		
28											•	
30												•
32					••							
34			•						•			
36				•					•			
38					•				•			
40					•					•		
42							•		•			
44								••	•			
46								•	•			
48									••			
50								•			•	
52									•		•	
54									•			•
56										••		
58											•	•
60												••
62					•			•	•			
64							•	••	•			
66								••	•			
68								••	•			
70								•	••			
72									••			
74								•	•		•	
76									••		•	
78									••			•
80									•		••	
82									•		•	•
84									•			••
86										•		••
88											•	••
90												••
92								••	••			••
94								•	••			••
96									•••			••

Outdoor Units Lineup

Cooling Only Series



Capacity (HP)	8	10	12	14	16	18	20	22	24	26	28	30	32
Power supply	380~415V/50Hz/3Ph, 380~415V/60Hz/3Ph												
8	•												
10		•											
12			•										
14				•									
16					•								
18						•							
20							•						
22								•					
24									•				
26										•			
28											•		
30												•	
32													•
34			•					•					
36				•				•					
38					•			•					
40						•		•					
42							•	•					
44								••					
46								•					
48									••				
50								•			•		
52									•		•		
54									•			•	
56										••			
58									•		•		
60											•	•	
62												•	•
64													••
66								•••					
68								••	•				
70								•	••				
72									•••				
74								•	•				
76									••		•		
78									••			•	
80									•		••		
82									•		•	•	
84									•			••	
86										•		•	
88											•	••	
90												•••	
92												••	•
94												•	••
96													•••

Outdoor Units Lineup

Cooling Only Series



Capacity (HP)	8	10	12	14	16	18	20	22	24
Power supply	208~230V/60Hz/3Ph								
8	•								
10		•							
12			•						
14				•					
16					•				
18						•			
20							•		
22								•	
24									•
26		•			•				•
28			•		•				
30			•		•	•			
32					••	•			
34			•					•	
36				•					•
38									•
40					•				•
42						•			•
44								••	
46								•	•
48								•	••
50					•			•	
52					•			•	•
54						••		•	
56						••			•
58					•			•	•
60					•				••
62						•		•	•
64						•			••
66							•		••
68								•	••
70								•	••
72									•••
74						•		•	•
76						•		•	••
78						•			•••
80						•		••	•
82						•		•	••
84							•	••	•
86							•	•	••
88						•			•••
90							•		•••
92								•	•••
94								•	•••
96									••••

High Efficiency

High Efficiency

Brushless DC Motor

- The brushless DC fan motor offers seamless speed modulation, automatically adjusting to system demands to maintain peak performance and operational efficiency at all times.



Stepless Control

- Operating on demand, high efficiency and energy saving.

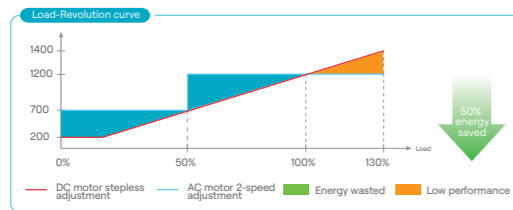

Inner-grooved Tube

- Increased surface area to enhance heat exchange efficiency.

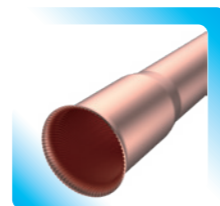

Subcool Technology

- Subcool technology reduces capacity deration under high ambient temperature condition, enhance cooling and efficiency performance.

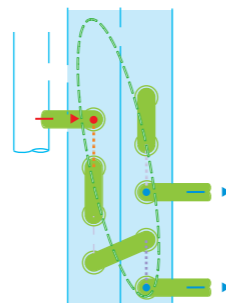

2-in-1 Refrigerant Flow Path

- Optimizes the volume, flow rate, and proportion of liquid refrigerant within the heat exchanger to enhance efficiency.

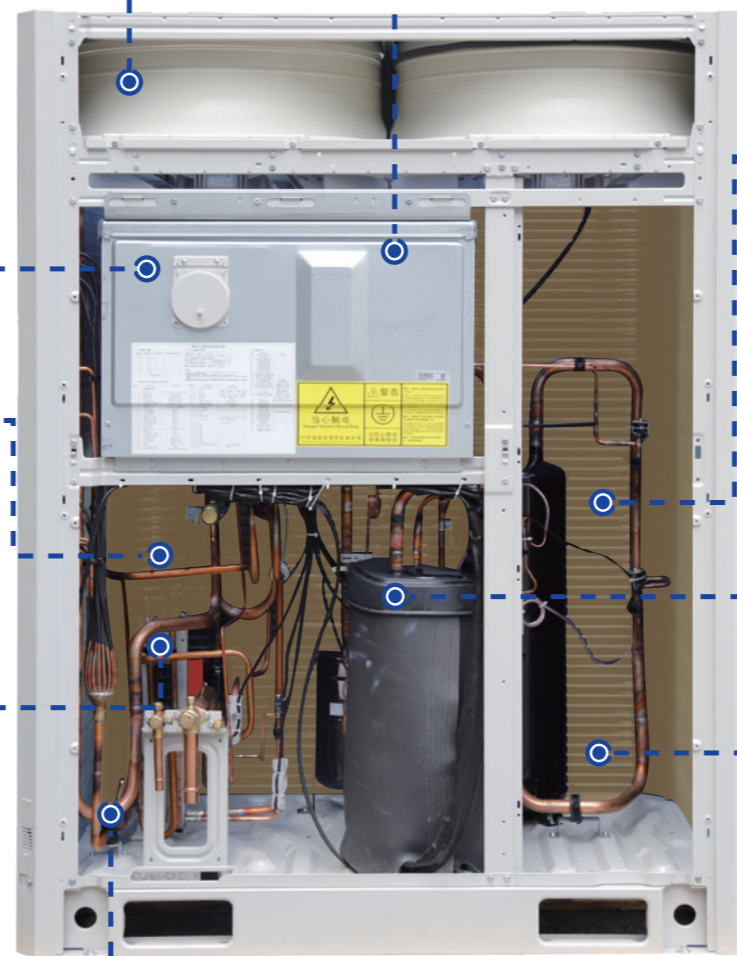

180° Sine Wave Control

- High precision rotor speed control.

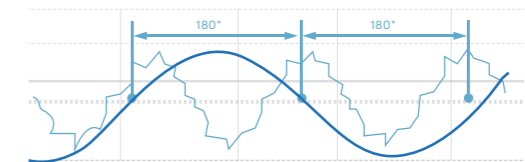

Golden Fins

- Golden fins enhance corrosion resistance performance, while improving heat exchange rate for better efficiency.

DC Inverter Compressor

- The Carrier XCT8 VRF system features a full DC inverter compressor paired with advanced 180° sine wave DC inverter control technology via the IPM board. This enables stepless modulation of compressor output to precisely match varying capacity demands. Equipped with high-efficiency twin-rotary compressor coupled with oil separator, the system ensures reliable performance with reduced noise levels.

G Shape Heat Exchanger

- Expanded heat exchanger surface area increases efficiency (Applicable to 22, 26, 28, 30 and 32HP).

Ultimate Reliability



Backup Operation

- Compressor backup operation***

In the event of a compressor failure, the system continues operation with the remaining compressor, maximising up time and user comfort.



*: Manual setup required at the outdoor unit.

- Module backup operation**

If one module of the outdoor unit fails, other modules continue operating, maximising up time and user comfort.



Refrigerant Leveling Technology

Built-in smart refrigerant monitoring function that measures the refrigerant pressure and triggers an error alert if it is undercharged or overcharged, ensuring the right amount of refrigerant charge during T&C for optimal system operation.



- 13 Extremely insufficient
- 12 Insufficient
- 11 Slightly insufficient
- 0 Normal
- 1 Slightly excess
- 2 Highly excess

Intelligent Rotation Operation Technology

Rotation operation of the combined modules enhance the operational lifespan of the compressor and overall system.

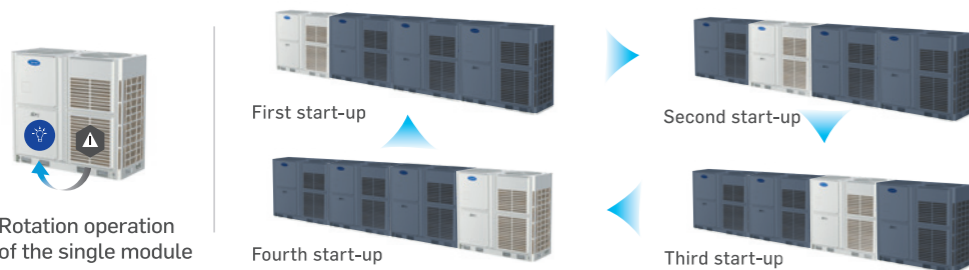

Ultimate Reliability

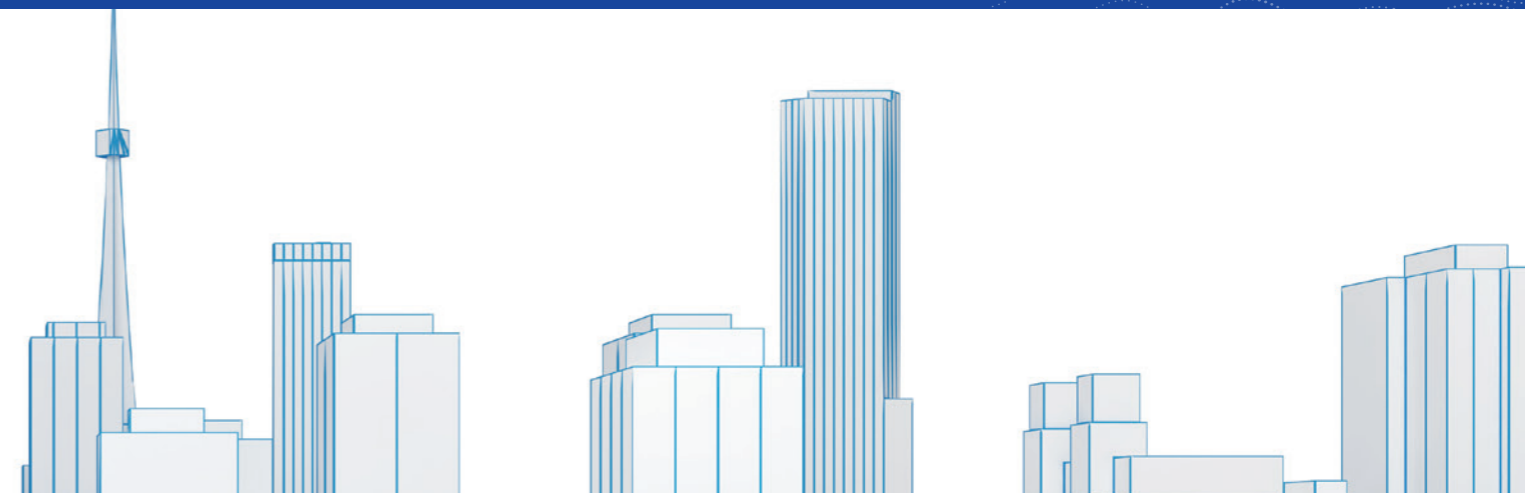

Reliable Multi-stage Oil Return Technology

The advanced 6-stage oil return technology ensures consistent oil return to safeguard the compressor and maintain system reliability.

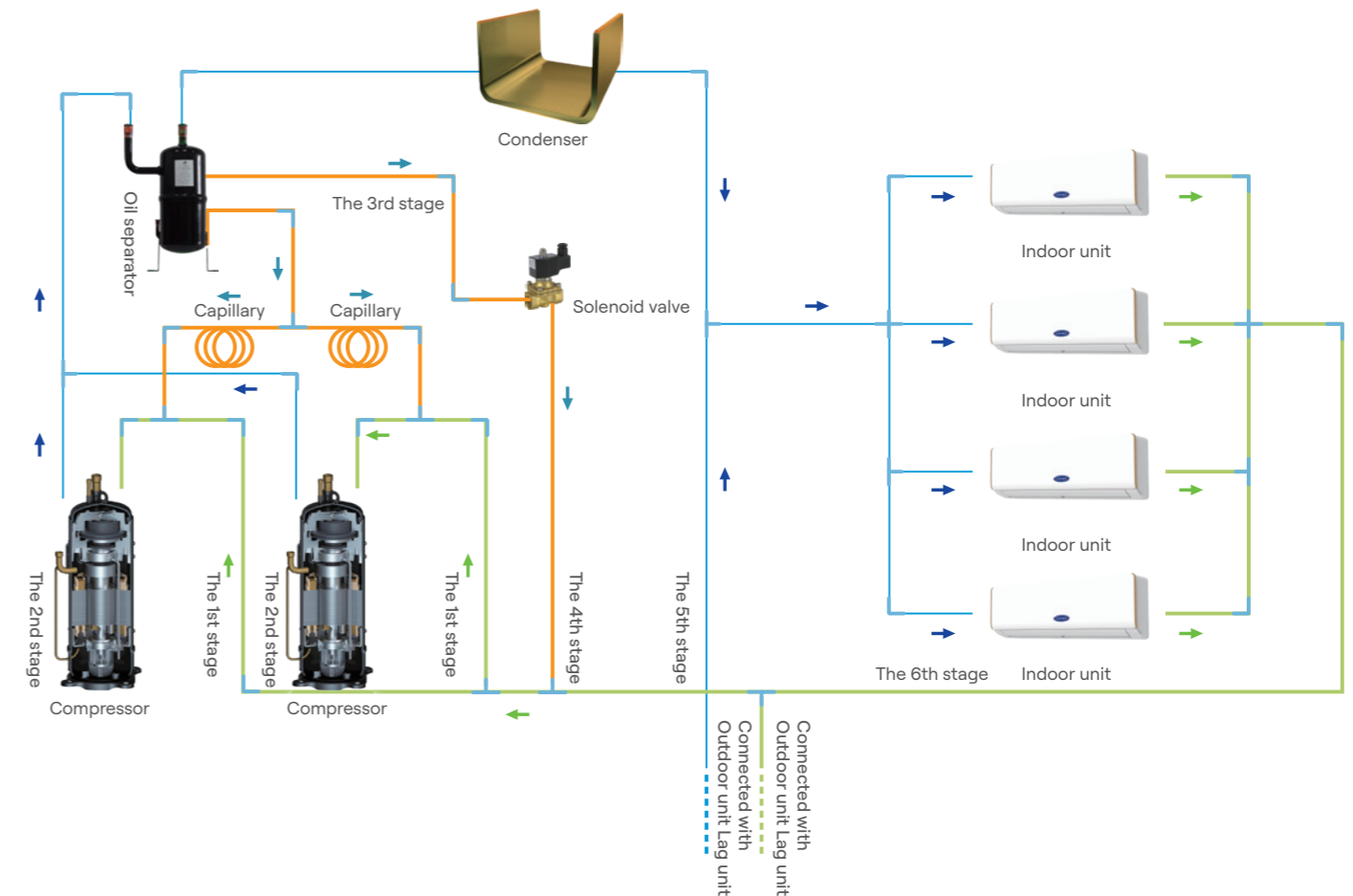

Incredible Flexibility

Large Operating Range

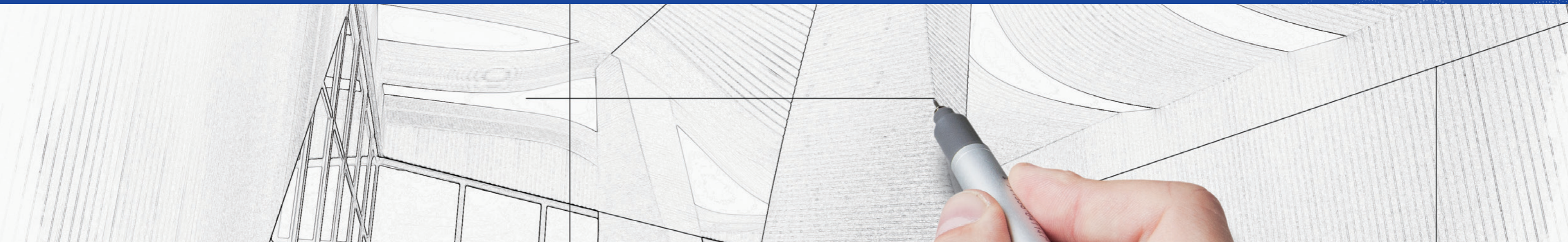

High External Static Pressure

The outdoor unit achieves high external static pressure up to 85 Pa*

Maximum 85Pa



*: Setting adjustment required at the outdoor unit.

Wide Operation Range

- Cooling at -5-55°C.
- Heating at -15-30°C.*



* : Applicable to Heat Pump line up

Flexible Long Piping Length Design

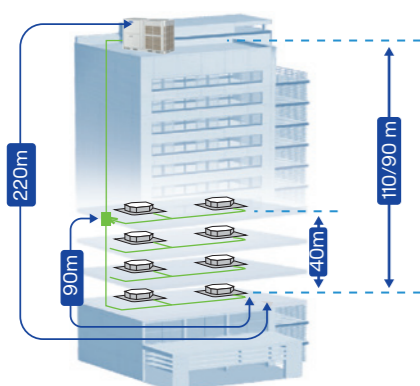

110	Maximum height difference between outdoor unit and indoor unit: • 110m (outdoor unit located below indoor unit) • 90m (outdoor unit located above indoor unit)
220	Maximum equivalent single way piping length 220m (longest actual single pipe is 190m)
90	Maximum piping length after first branch
40	Maximum height difference between indoor units
1000	Maximum total piping length 1000m

Refrigerant Cooling Technology

The Carrier XCT8 keeps PCB cool with low-temperature refrigerant, delivering enhanced cooling stability even in high outdoor temperature.



Easy Installation



All-Units-On Operation

Automatically detects and verifies system connections, communication, and operational status, then activates all indoor units simultaneously, eliminating the need for manual startup of each unit and reducing testing and commissioning time.



360° Pipe Connection

Designed for flexibility, the refrigerant pipeline allows connections from either direction, while the front-mounted compressor enables easier maintenance.



Auto Refrigerant Charge

Monitors, analyzes, and determines refrigerant levels in real time, automatically charging the precise amount required for optimal system performance.

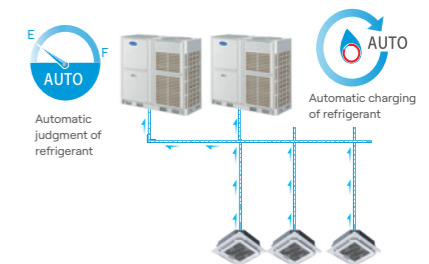

* This is an optional add-on function upon request.

Smart Positioning

The outdoor and indoor units are easy to locate and identify on-site - through gentle, audible sound produced by the units connected on the same system.

Automatic Addressing

The indoor unit address will be assigned automatically by the system.

- Saves manpower and setting time.
- Avoid repeated addresses.

Easy for Transportation & Positioning

Compact modular design minimizes space constraints during transport and installation.

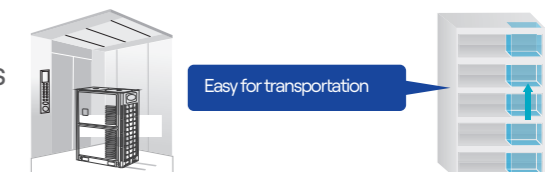

Easy Installation Enhanced System Performance



Doctor Kit

- Real-time monitoring of indoor and outdoor units operating parameters.
- Automatically performs a full system diagnostic, streamlining troubleshooting and enabling monitoring of system status.
- Full control of indoor unit settings.

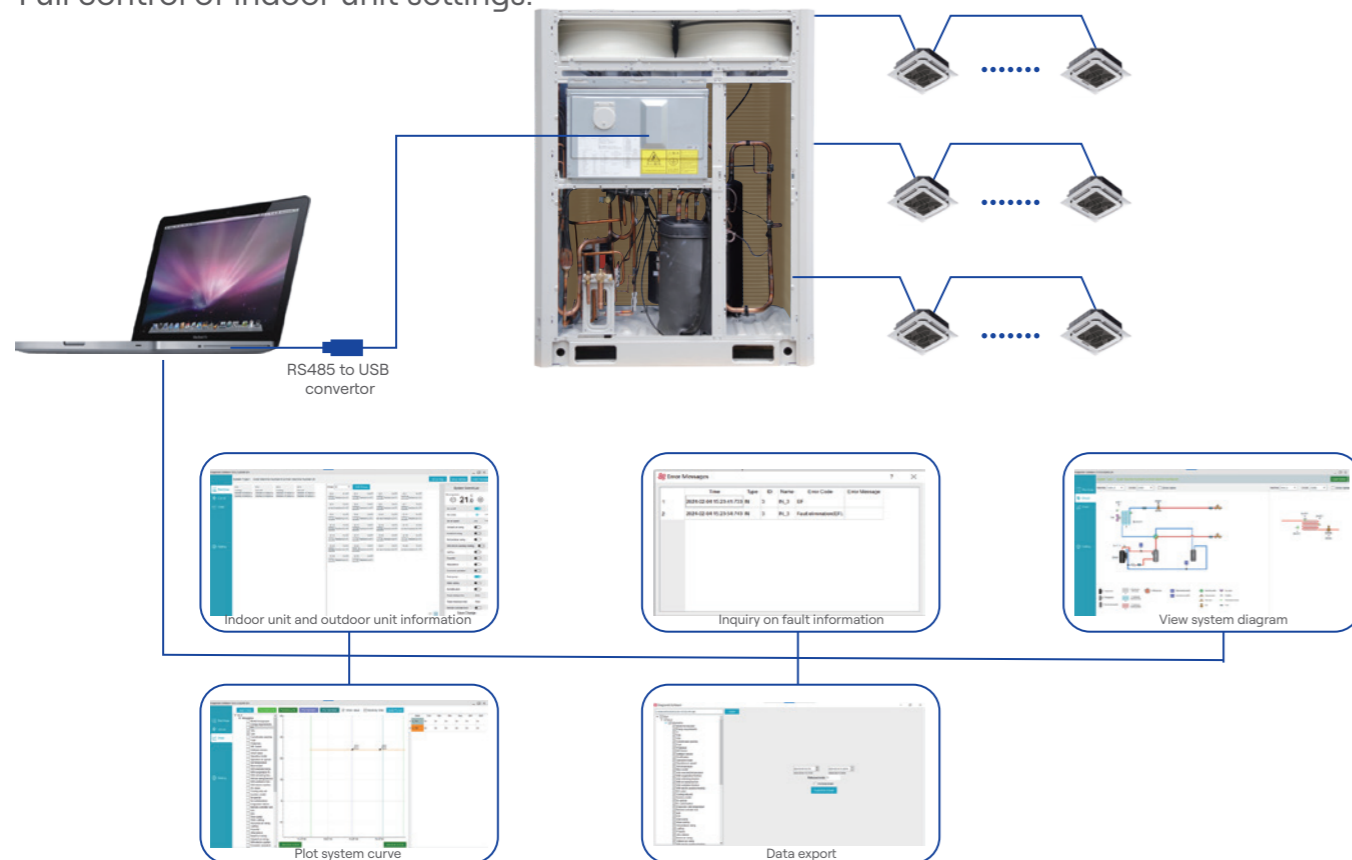

Power Saving Mode

The outdoor unit offers 7 levels of adjustable power limit settings, reducing energy consumption while maintaining continuous system operation.



Intelligent Allocation of Capacity Technology

Intelligent load distribution is managed based on the outdoor unit operational status and refrigerant pipe pressure. When cooling demand reaches 85% of the unit capacity, the next module is automatically activated to ensure seamless performance.

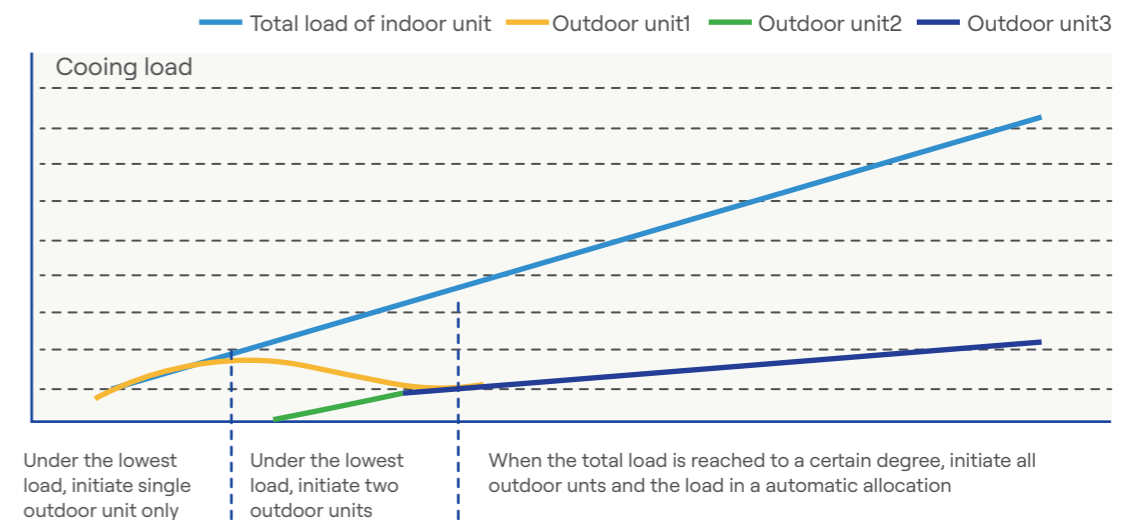

Enhanced User Comfort



Enhanced User Comfort



Night-time Noise Control

The compressor and fan motor operate in low noise mode with Night-time noise control function, enabling noise level reductions of 8dB(A). A total of four options are available for customisation of night-mode initiation time from peak temperature and duration of night-mode operation.

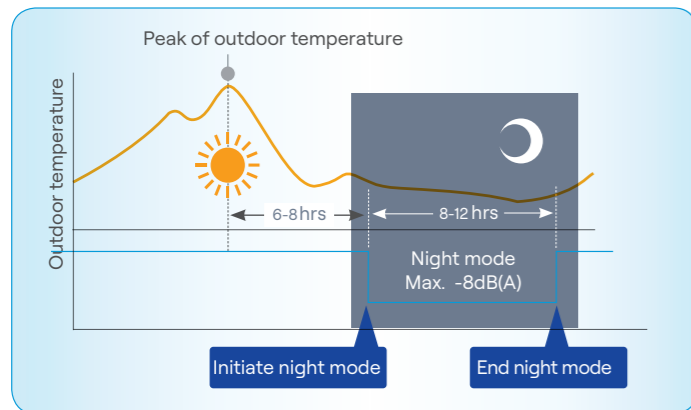

Setting	Night-mode Initiation from Peak Temperature	Night-mode Duration
Option 1 (Standard)	6 hours	10 hours
Option 2	8 hours	10 hours
Option 3	6 hours	12 hours
Option 4	8 hours	8 hours

Low Noise Fan

The aerodynamic design of the fan blade is optimized to minimize vibration and reduce pressure loss during operation, enhancing overall airflow efficiency and acoustic performance.



Intelligent Defrost

Utilizing a precision temperature sensor to monitor the condenser coil, this sensor-driven logic intelligently initiates defrost cycles only when necessary, thereby extending continuous heating periods, enhancing thermal comfort, and improving overall energy efficiency.

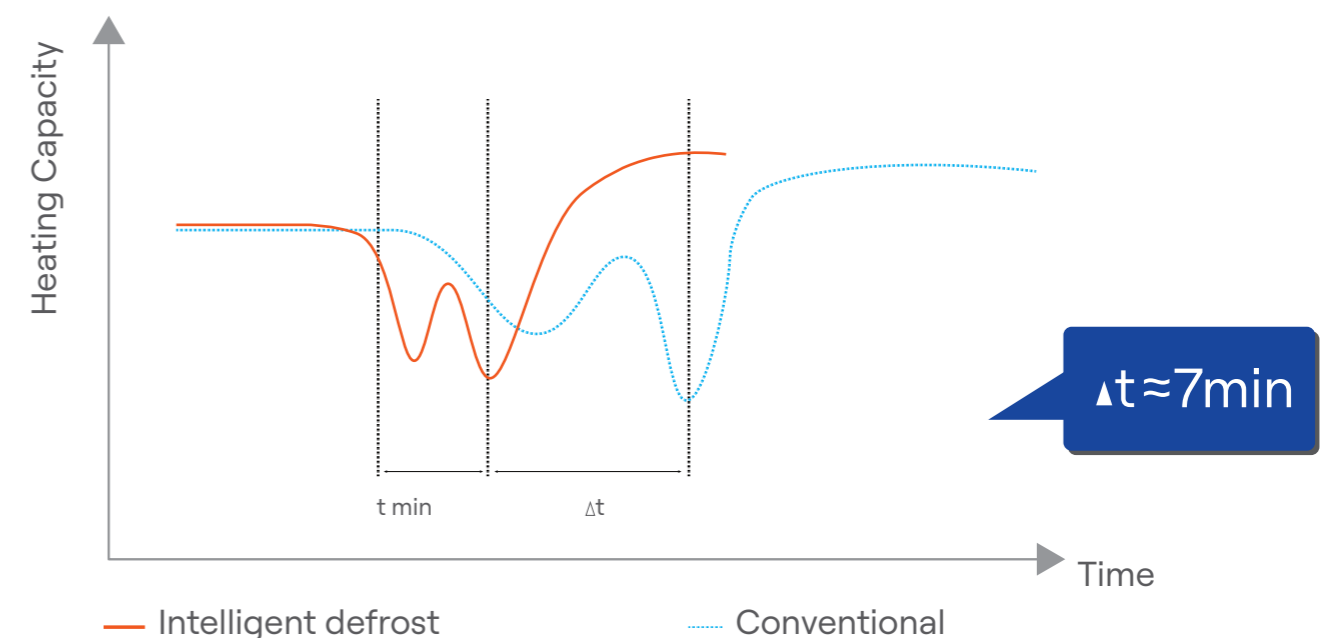

Enhanced User Comfort



Enhanced User Comfort



Precise Temperature Control

The Carrier XCT8 series incorporates adaptive control technology to dynamically regulate evaporation and condensation temperatures. During cooling, it optimizes the evaporation temperature, while in heating mode, it adjusts the condensation temperature. This intelligent modulation minimizes indoor temperature fluctuations, ensuring consistent comfort and improved efficiency performance.

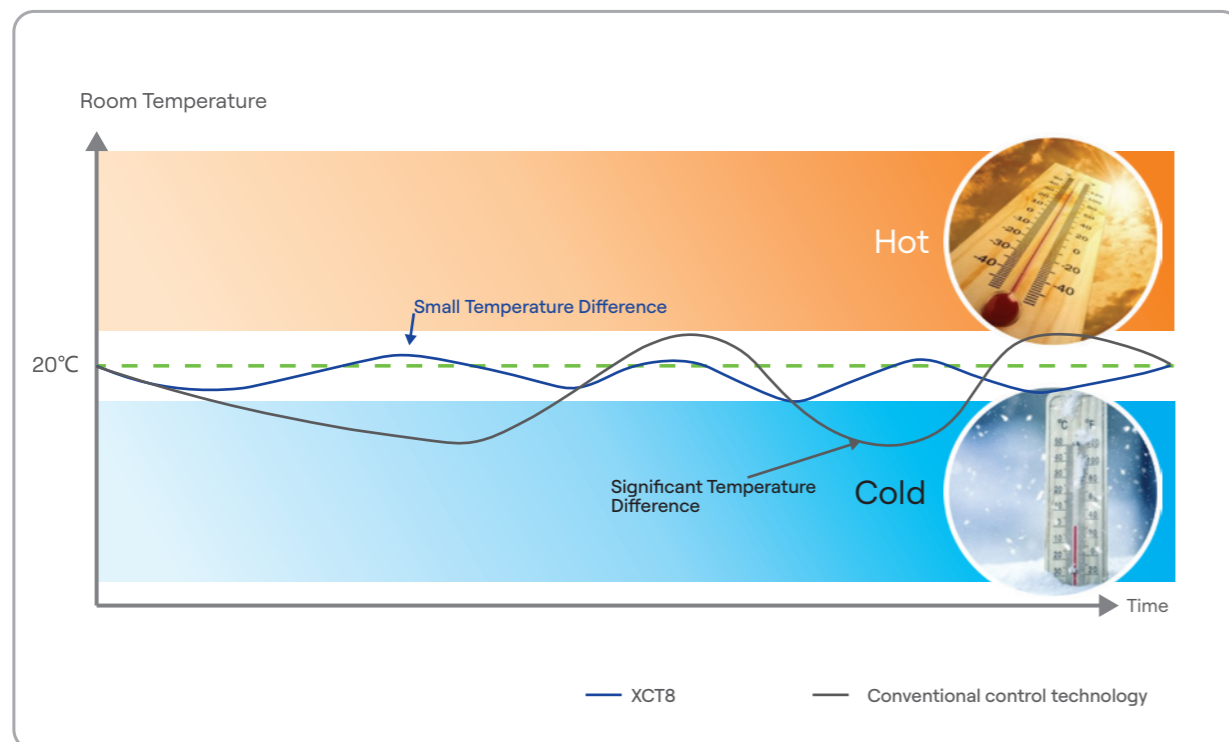

Intelligent Control

• Intelligent gateway control system

- One central controller connects up to 120 systems.
- One central controller controls up to 1024 indoor units.
- Each gateway monitors and controls all indoor units.
- Top-discharge VRF, side-discharge VRF and modular side-discharge VRF with built-in Modbus.

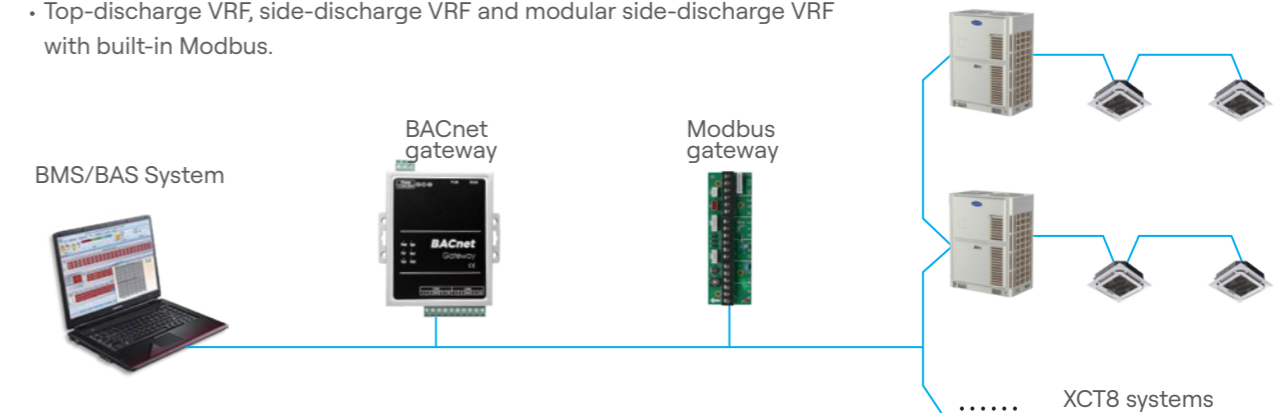

• Key card control

- The air-conditioning unit is compatible with key card access control and power management systems. This integration ensures the unit operates only when a key card is inserted, automatically shutting off when the card is removed, effectively reducing unnecessary energy consumption and enhancing operational efficiency.

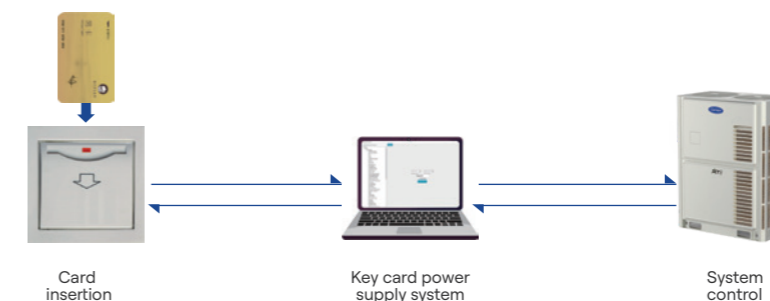

Enhanced User Comfort

Wide Range of Options



Intelligent Control

• Smart App-based remote control system

Compatible with both Android and iOS devices, the system supports central control via Carrier GCS App on smartphones and tablets. It enables multiple users to manage the same indoor unit and allows seamless coordination of multiple units from a single interface—ideal for both residential and commercial environments.

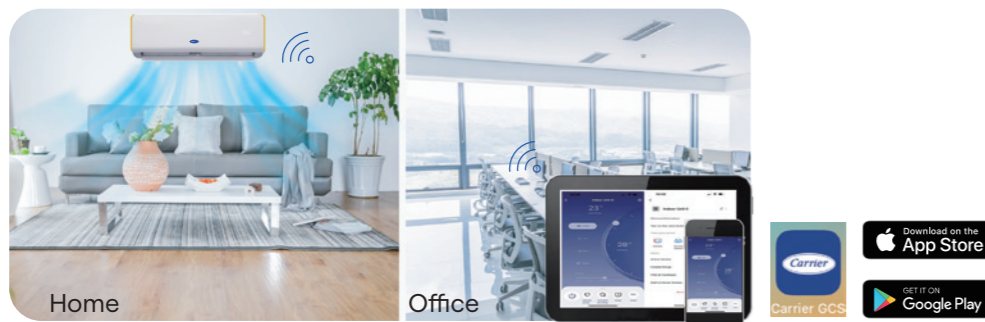

• Smart scenario

Scenario-based control represents a significant advancement in air conditioning technology, offering users unparalleled flexibility in managing HVAC operations. By leveraging IoT integration, the system intelligently adapts to real-time weather conditions and air quality based on data sourced from the internet. This dynamic approach elevates operational performance, ensuring comfort, reliability, and energy efficiency.

- Up to 100 scenarios
- Up to 10 conditions for each scenario
- Up to 150 actions possible for each scenario

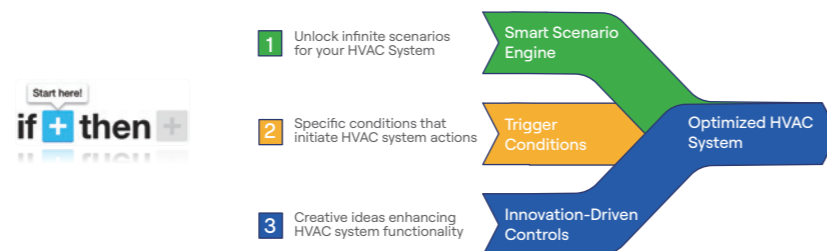

3 Outdoor Modules Series



Free Combination

Flexibility in the choice of outdoor unit combination to meet the cooling capacity, efficiency and space requirement.



- Note
- Combinations using 8~24HP: Maximum 4 units in total.
 - Combinations using 26~32HP: Maximum 3 units in total.
 - The capacity different between the largest and smallest unit in the combination must be ≤10HP.

Complete Line Up of Indoor Units

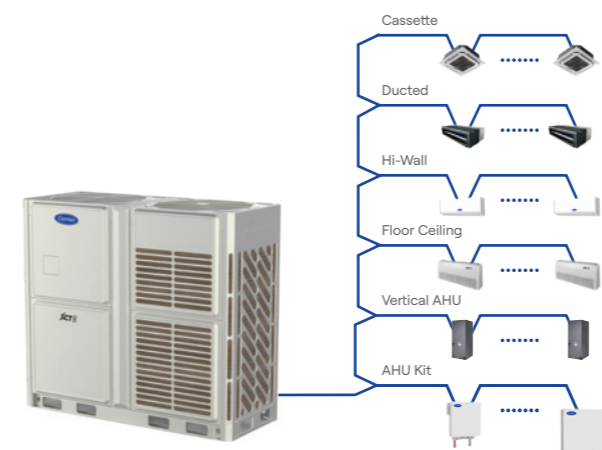

More Connectible Indoor Units

- Accommodates up to 100 indoor units per System.
- Indoor unit to outdoor unit diversity ratio up to 130%.

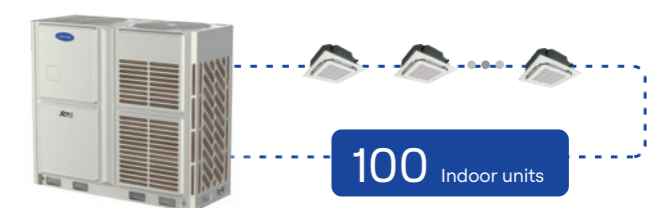

Specifications

Heat Pump Series



Model	38VT008 183HGSS	38VT010 183HGSS	38VT012 183HGSS	38VT014 183HGSS	38VT016 183HGSS	38VT018 183HGSS	38VT020 183HGSS	38VT022 183HGSS	38VT024 183HGSS	38VT026 183HGSS	38VT028 183HGSS	38VT030 183HGSS		
Power supply	380~415V/50Hz/3Ph, 380~415V/60Hz/3Ph													
Cooling	Capacity	HP	8.0	10.0	12.0	14.0	16.0	18.0	20.0	22.0	24.0	26.0	28.0	30.0
		kW	25.2	28.0	33.5	40.0	45.0	50.0	56.0	61.5	67.0	73.0	80.0	85.0
		kBtu/h	86.0	95.5	114.0	136.5	153.5	170.6	191.0	209.8	228.6	249.0	272.9	290.0
	Running current	A	8.49	9.73	12.44	15.38	17.93	19.68	23.16	25.57	28.73	29.09	33.09	36.84
	Power input	kW	5.20	5.96	7.61	9.41	10.98	12.05	14.18	15.65	17.59	17.80	20.25	22.55
	EER	W/W	4.85	4.70	4.40	4.25	4.10	4.15	3.95	3.93	3.81	4.10	3.95	3.77
Heating	Capacity	kW	27.0	31.5	37.5	45.0	50.0	56.0	63.0	69.0	75.0	81.5	88.0	95.0
		kBtu/h	92.1	107.5	128.0	153.5	170.6	191.0	214.9	235.4	255.8	278.1	300.3	324.1
	Running current	A	8.90	10.50	13.10	16.60	18.90	20.80	25.10	27.98	31.10	31.40	35.90	40.20
	Power input	kW	5.45	6.44	8.02	10.19	11.57	12.70	15.32	17.13	19.02	19.24	22.00	24.63
COP	W/W	5.20	5.15	4.92	4.65	4.55	4.64	4.33	4.24	4.15	4.46	4.21	4.06	
Number of connectible indoor units		13	16	19	23	26	29	33	36	39	43	46	50	
Diversity ratio		50%~130%												
Airflow	m ³ /h	11000	11000	12000	14000	16000	16000	16000	16000	24000	25000	25000	24000	
External static pressure	Pa	85*												
Compressor	Quantity	1						2						
	Type	Twin Rotary												
Motor	Type	DC												
	Quantity	1						2						
Refrigerant	Type	R410A												
	Charging amount	kg	9	9	11	14	14	16	16	16	16	20	20	23
Dimension(WxHxD)	mm	990×1740×840				1340×1740×840				1990×1740×840				
Weight	kg	205	205	210	250	270	300	300	309	352	412	412	452	
Sound pressure level	dB(A)	58	58	58	60	61	63	63	63	63	66	66	66	
Refrigerant piping	Total piping length	m	1000	1000	1000	1000	1000	1000	1000	1000	1000	1000	1000	
	Height difference (Outdoor unit above)	m	90	90	90	90	90	90	90	90	90	90	90	
	Height difference (Outdoor unit below)	m	110	110	110	110	110	110	110	110	110	110	110	
	Liquid side	mm	Ø12.7	Ø12.7	Ø12.7	Ø15.88	Ø15.88	Ø15.88	Ø15.88	Ø15.88	Ø15.88	Ø22.2	Ø22.2	Ø22.2
	Gas side	mm	Ø22.2	Ø22.2	Ø22.2	Ø28.6	Ø28.6	Ø28.6	Ø28.6	Ø28.6	Ø28.6	Ø35	Ø35	Ø35
Cooling operation range	Outdoor unit	°C	-5~55											
	Indoor unit	°C	16~32											
Heating operation range	Outdoor unit	°C	-15~30											
	Indoor unit	°C	16~32											

Notes:
 1. Setting adjustment required at the outdoor unit.*
 2. The cooling conditions: indoor side 27°C(80.6°F) DB, 19°C(60°F)WB outdoor side 35°C(95°F) DB.
 3. Sound level: measured at a point 1 m in front of the unit at a height of 1.5 m. During actual operation, these values are normally somewhat higher as a result of ambient conditions.
 4. The above data may be changed without notice for future improvement on quality and performance.

Specifications

Cooling Only Series



Model	38VT008 183CGSS	38VT010 183CGSS	38VT012 183CGSS	38VT014 183CGSS	38VT016 183CGSS	38VT018 183CGSS	38VT020 183CGSS	38VT022 183CGSS	38VT024 183CGSS	38VT026 183CGSS	38VT028 183CGSS	38VT030 183CGSS	38VT032 183CGSS		
Power supply	380~415V/50Hz/3Ph, 380~415V/60Hz/3Ph														
Cooling	Capacity	HP	8.0	10.0	12.0	14.0	16.0	18.0	20.0	22.0	24.0	26.0	28.0	30.0	32.0
		kW	25.2	28.0	33.5	40.0	45.0	50.0	56.0	61.5	67.0	73.0	80.0	85.0	90.0
		kBtu/h	86.0	95.5	114.0	136.5	153.5	170.6	191.0	209.8	228.6	249.0	272.9	290.0	307.1
	Running current	A	8.49	9.73	12.44	15.38	17.93	20.17	23.16	25.76	29.50	29.82	33.09	37.84	44.02
	Power input	kW	5.20	5.96	7.61	9.41	10.98	12.35	14.18	15.77	18.06	18.25	20.25	23.16	26.95
	EER	W/W	4.85	4.70	4.40	4.25	4.10	4.05	3.95	3.90	3.71	4.00	3.95	3.67	3.34
Number of connectible indoor units		13	16	19	23	26	29	33	36	39	43	46	50	53	
Diversity ratio		50%~130%													
Airflow	m ³ /h	11000	11000	12000	14000	14000	16000	16000	16000	16000	24000	25000	25000	24000	
External static pressure	Pa	85*													
Compressor	Quantity	1						2							
	Type	Twin Rotary													
Motor	Type	DC													
	Quantity	1						2							
Refrigerant	Type	R410A													
	Charging amount	kg	9	9	11	14	14	14	16	16	16	16	20	20	23
Dimension(WxHxD)	mm	990×1740×840				1340×1740×840				1990×1740×840					
Weight	kg	205	205	210	250	250	270	300	300	309	352	412	412	452	
Sound pressure level	dB(A)	58	58	58	60	60	61	63	63	63	63	66	66	66	
Refrigerant Pipe	Total piping length	m	1000	1000	1000	1000	1000	1000	1000	1000	1000	1000	1000	1000	
	Height difference (Outdoor unit above)	m	90	90	90	90	90	90	90	90	90	90	90	90	
	Height difference (Outdoor unit below)	m	110	110	110	110	110	110	110	110	110	110	110	110	
	Liquid side	mm	Ø12.7	Ø12.7	Ø12.7	Ø15.88	Ø15.88	Ø15.88	Ø15.88	Ø15.88	Ø15.88	Ø22.2	Ø22.2	Ø22.2	
	Gas side	mm	Ø22.2	Ø22.2	Ø22.2	Ø28.6	Ø28.6	Ø28.6	Ø28.6	Ø28.6	Ø28.6	Ø28.6	Ø28.6	Ø35	Ø35
Cooling operation range	Outdoor unit	°C	-5~55												
	Indoor unit	°C	16~32												

Notes:
 1. Setting adjustment required at the outdoor unit.*
 2. The cooling conditions: indoor side 27°C(80.6°F) DB, 19°C(60°F)WB outdoor side 35°C(95°F) DB.
 3. Sound level: measured at a point 1 m in front of the unit at a height of 1.5 m. During actual operation, these values are normally somewhat higher as a result of ambient conditions.
 4. The above data may be changed without notice for future improvement on quality and performance.

Specifications

Side-discharge Mini VRF

Cooling Only Series



8/10/12HP



14/16/18HP



20/22HP



24HP

Model	38VT008 18ACGSS	38VT010 18ACGSS	38VT012 18ACGSS	38VT014 18ACGSS	38VT016 18ACGSS	38VT018 18ACGSS	38VT020 18ACGSS	38VT022 18ACGSS	38VT024 18ACGSS		
Power supply	208~230V/60Hz/3Ph										
Cooling	Capacity	HP	8.0	10.0	12.0	14.0	16.0	18.0	20.0	22.0	24.0
		kW	25.2	28.0	33.5	40.0	45.0	50.0	56.0	61.5	67.0
	kBtu/h	86.0	95.5	114.3	136.5	153.5	170.6	191.1	209.8	228.6	
	Running current	A	14.22	16.48	22.33	25.49	29.60	34.17	42.54	49.16	54.64
	Power input	kW	5.27	6.10	8.27	9.45	10.97	12.66	15.76	18.21	20.24
EER	W/W	4.79	4.59	4.05	4.24	4.10	3.95	3.55	3.38	3.31	
Number of connectible indoor units	13	16	19	23	26	29	33	36	39		
Diversity ratio	50%~130%										
Airflow	m ³ /h	10500	10500	10500	13500	13500	13500	16000	16000	16000	
External static pressure	Pa	85*									
Compressor	Quantity	1					2				
	Type	Twin Rotary									
Motor	Type	DC									
	Quantity	1					2				
Refrigerant	Type	R410A									
	Charging amount	kg	8	8	8	12	12	13	14	15	17
Dimension(WxHxD)	mm	990×1740×840					1340×1740×840				
Weight	kg	208	208	208	260	260	288	296	296	306	
Sound pressure level	dB(A)	59	61	62	62	63	64	64	66	66	
Refrigerant pipe	Total piping length	m	1000	1000	1000	1000	1000	1000	1000	1000	1000
	Height difference (Outdoor unit above)	m	90	90	90	90	90	90	90	90	90
	Height difference (Outdoor unit below)	m	110	110	110	110	110	110	110	110	110
	Liquid side	mm	Ø12.7	Ø12.7	Ø12.7	Ø15.88	Ø15.88	Ø15.88	Ø15.88	Ø15.88	Ø15.88
	Gas side	mm	Ø22.2	Ø22.2	Ø22.2	Ø28.6	Ø28.6	Ø28.6	Ø28.6	Ø28.6	Ø28.6
Cooling operation range	Outdoor unit	°C	-5~55								
	Indoor unit	°C	16~32								

Notes:
 1. Setting adjustment required at the outdoor unit*
 2. The cooling conditions: indoor side 27°C(80.6°F) DB, 19°C(60°F)WB outdoor side 35°C(95°F) DB.
 3. Sound level: measured at a point 1 m in front of the unit at a height of 1.5 m. During actual operation, these values are normally somewhat higher as a result of ambient conditions.
 4. The above data may be changed without notice for future improvement on quality and performance.



High Efficiency

High Efficiency

High Efficiency DC Motor

- High efficiency
- Low noise



Large Air Flow Fan Blade

- High air flow
- Low noise design
- Low vibration



Cross Flow Fins

- Reduce wind resistance and improve heat exchange efficiency.

High Efficiency Heat Exchanger

- Featuring anti-corrosive golden hydrophilic fins and a high-efficiency cross-flow, low-pressure design, this system enhances heat transfer performance, delivering superior heat exchange efficiency and long-lasting durability.

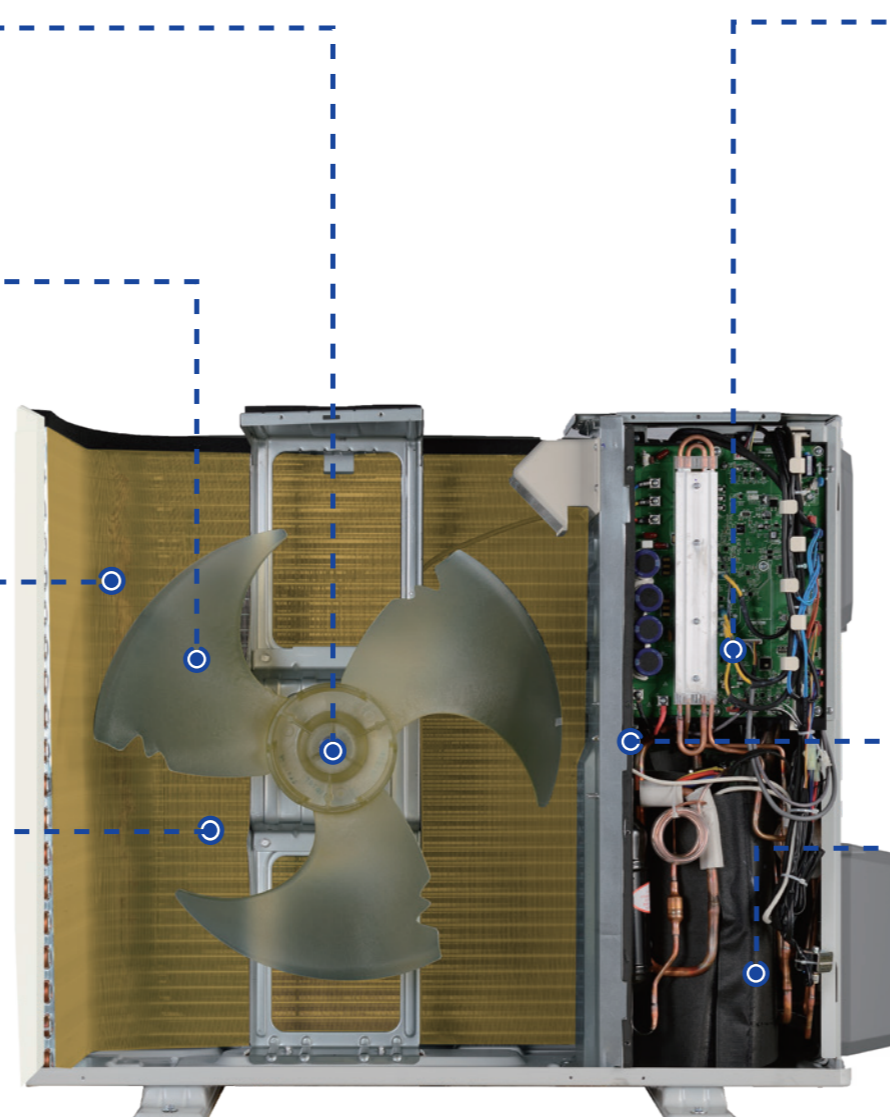
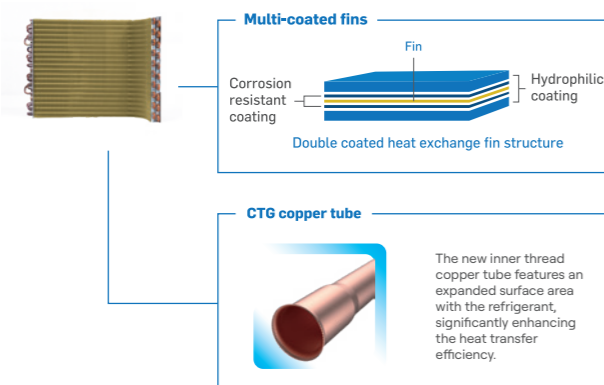

180° Sine Wave Technology

Powered by advanced 180° sine wave technology, this system significantly reduces motor vibration and electromagnetic noise for smoother, quieter operation.

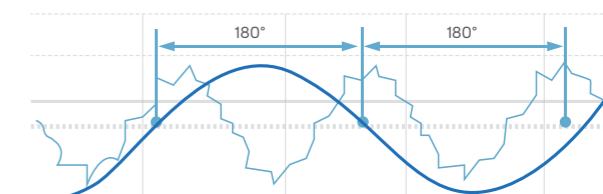

2-in-1 Refrigerant Flow Path

- Optimizes the volume, flow rate, and proportion of liquid refrigerant within the heat exchanger to enhance efficiency.

Twin-rotary Inverter compressor

Twin-rotary DC Inverter Compressor

- A high-efficiency, reliable compressor that delivers outstanding performance especially under part-load conditions.

High Efficiency, Low Noise

- Optimized system efficiency and reduced noise during operation with the latest technology.

Low Vibration

- Incorporating a 2-cylinder structure, the compressor design minimizes vibration during startup and operation



Enhanced User Comfort

Noise Control Design

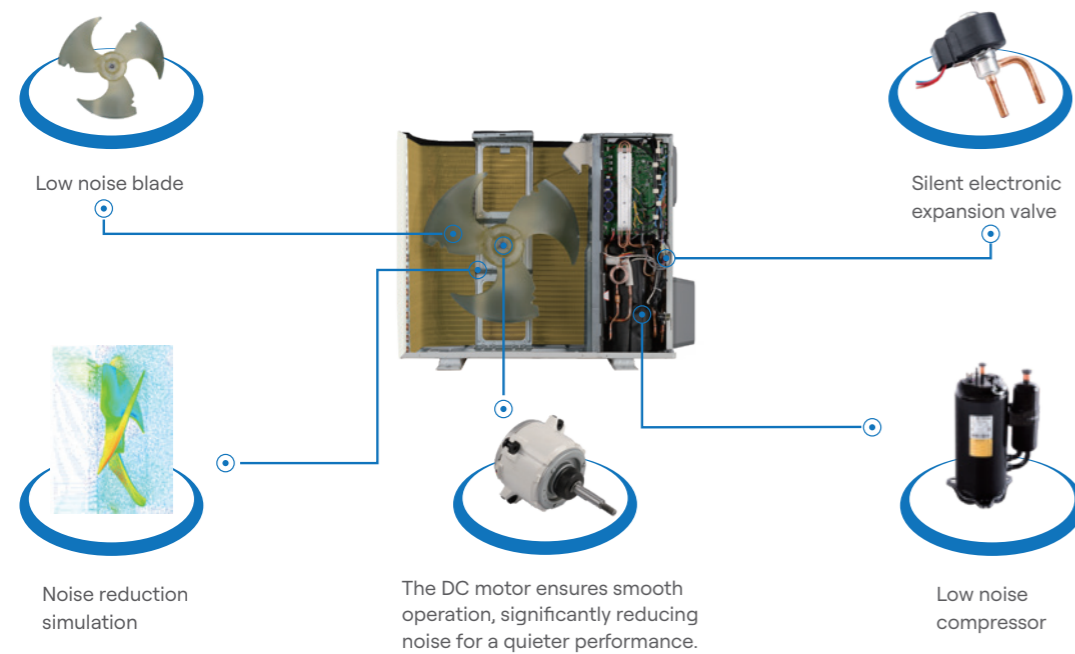

Night-time Noise Control

The compressor and fan motor are equipped with a low-noise operation mode, enabling a sound pressure level reduction of up to 8 dB(A) during night time operation.

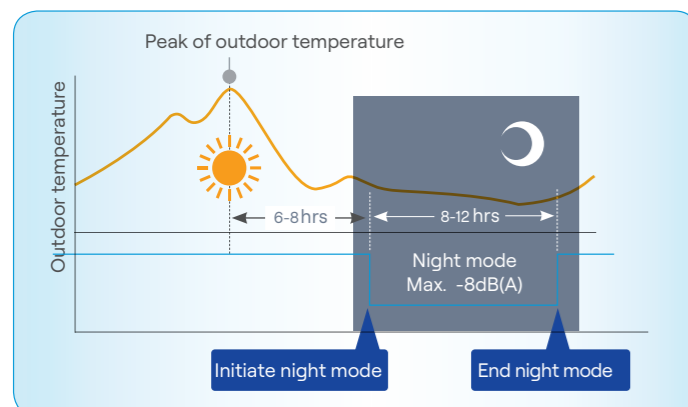

Setting	Night-mode Initiation from Peak Temperature	Night-mode Duration
Option 1 (Standard)	6 hours	10 hours
Option 2	8 hours	10 hours
Option 3	6 hours	12 hours
Option 4	8 hours	8 hours

Large Operating Range

Wide Operation Range

- Wide temperature range enables wider applications of the system in hotter regions.
- Maximum cooling operating temperature is designed up to 55°C.

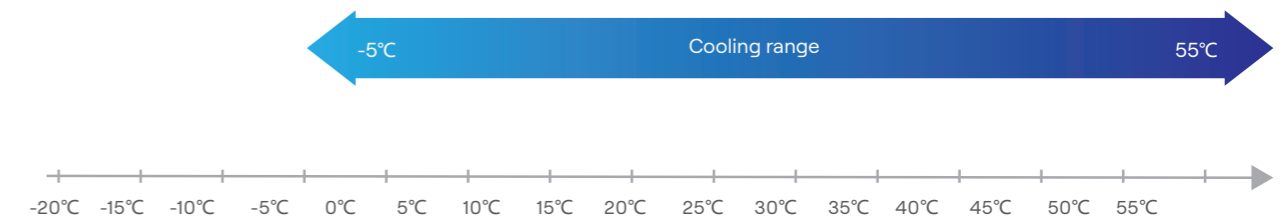

Incredible Flexibility

Long-pipe Connection

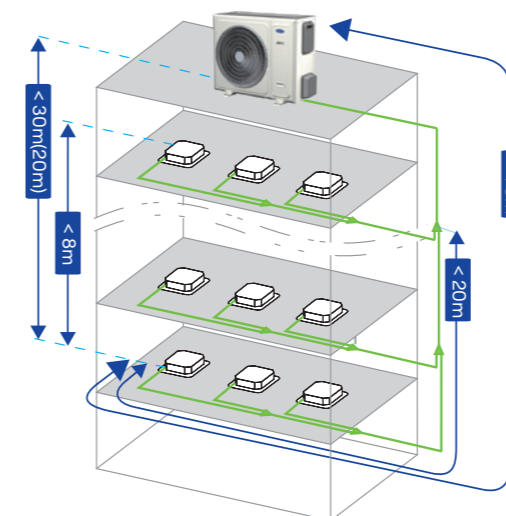

- 30 Maximum height difference between outdoor units and indoor units:
 - 20m (outdoor unit located below indoor unit)
 - 30m (outdoor unit located above indoor unit)
- 8 Height difference between indoor units: ≤8 m
- 70 Max. single way piping length: 60/70m (actual/equivalent)
- 20 Max. piping length after first branch to furthest indoor units: 20m
- 120 Max. total piping length: 100/120m (actual/equivalent)

Easy Installation & Service

All-Units-On Operation

Automatically detects and verifies system connections, communication, and operational status, then activates all indoor units simultaneously, eliminating the need for manual startup of each unit and reducing testing and commissioning time.

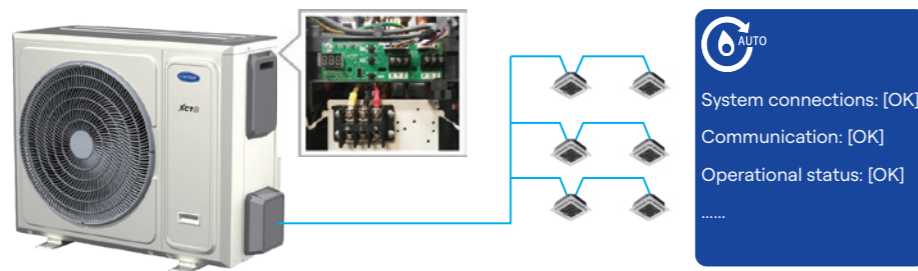

Automatic Addressing

The indoor unit address will be assigned automatically by the system.

- Saves manpower and setting time.
- Avoid repeated addresses.



Ultimate Reliability

Oil Return Technology

- The high-efficiency oil separator effectively extracts and stores oil, ensuring smooth return flow to the compressor.
- Oil return logic to control the oil level of each module.

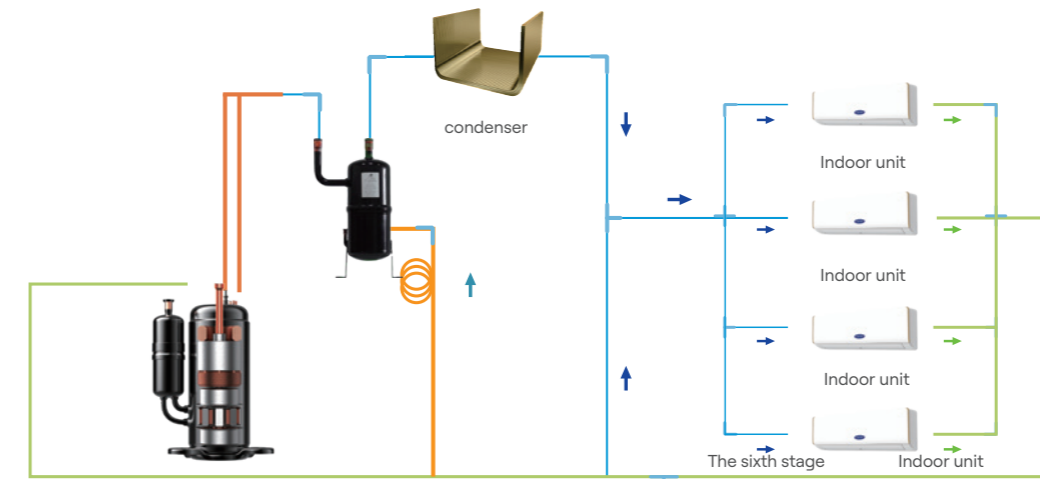

Refrigerant Cooling Technology

The Carrier XCT8 keeps PCB cool with low-temperature refrigerant—delivering enhanced cooling stability up to 55°C outdoor temperature.

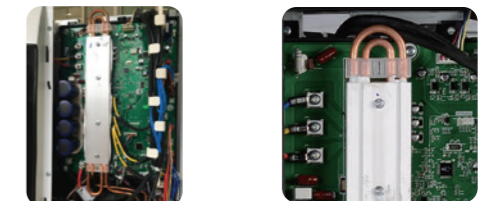

Digital Display

Digital display on PCB, shows system operation status and error codes.

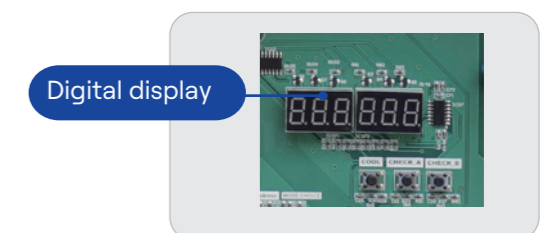

Specifications

Side-discharge Mini VRF Series



8kW
1Ph & 3Ph



10/11.2kW
1Ph & 3Ph



12/14/16/18kW
1Ph & 3Ph



12.5/14/16/18kW
3Ph



20/22.4kW
3Ph



26/28/33.5kW
3Ph

Model	38VS080 C8SCGSS	38VS100 C8SCGSS	38VS112 C8SCGSS	38VS120 C8SCGSS	38VS140 C8SCGSS	38VS160 C8SCGSS	38VS180 C8SCGSS	38VS125 C83CGSS	38VS140 C83CGSS	38VS160 C83CGSS		
Power supply	220-240V/50Hz/1Ph, 208-230V/60Hz/1Ph							380V-415V/50Hz/3Ph, 380V-415V/60Hz/3Ph				
Cooling	Capacity	HP	3.0	3.5	4.0	4.5	5.0	6.0	6.5	4.5	5.0	6.0
		kW	8.0	10.0	11.2	12.0	14.0	16.0	18.0	12.5	14.0	16.0
	kBtu/h	27.3	34.1	38.2	40.9	47.8	54.6	61.4	42.7	47.8	54.6	
	Running current	A	8.3	11.0	14.2	12.8	15.8	19.6	24.7	6.4	7.1	8.2
	Power input	kW	1.82	2.39	3.09	2.80	3.44	4.28	5.37	3.81	4.21	4.88
EER	W/W	4.40	4.18	3.63	4.29	4.07	3.74	3.35	3.28	3.30	3.30	
Number of connectible indoor units	6	6	7	8	8	9	9	8	8	9		
Diversity ratio	50-130%											
Airflow	m ³ /h	3300	4000	4000	5500	5500	5500	5500	4000	5500	5500	
External static pressure	Pa	10										
Compressor	Quantity	1										
	Type	Twin rotary										
Motor	Type	DC										
	Quantity	1										
Refrigerant	Type	R410A										
	Charging amount	kg	2.0	2.6	2.8	3.8	3.8	3.8	4.2	3.0	3.5	3.8
Dimension(WxHxD)	mm	935×702×383	1032×810×445		1100×870×528				1032×810×445	1100×870×528		
Weight	kg	47.0	60.0	63.0	91.0	91.0	91.0	92.5	67.4	87.5	90.0	
Sound pressure level	dB(A)	55	57	57	59	59	59	59	56	57	57	
Refrigerant pipe	Total piping length	m	100	100	100	100	100	100	100	100	100	
	Height difference (Outdoor unit above)	m	30	30	30	30	30	30	30	30	30	
	Height difference (Outdoor unit below)	m	20	20	20	20	20	20	20	20	20	
	Liquid side	mm	Ø9.52	Ø9.52	Ø9.52	Ø9.52	Ø9.52	Ø9.52	Ø9.52	Ø9.52	Ø9.52	Ø9.52
	Gas side	mm	Ø15.88	Ø15.88	Ø15.88	Ø15.88	Ø15.88	Ø15.88	Ø15.88	Ø15.88	Ø15.88	Ø15.88
Cooling operation range	Outdoor unit	°C	-5~55									
	Indoor unit	°C	16~32									

Notes:
 1. Cooling operating temperature range is from -5°C to 55°C.
 2. The cooling conditions: indoor side 27°C(80.6°F) DB, 19°C(60°F)WB outdoor side 35°C(95°F) DB.
 3. Sound level: measured at a point 1 m in front of the unit at a height of 1.5 m. During actual operation, these values are normally somewhat higher as a result of ambient conditions.
 4. The above data may be changed without notice for future improvement on quality and performance.

Specifications

38VS125 183CGSS	38VS140 183CGSS	38VS160 183CGSS	38VS180 183CGSS	38VS200 183CGSS	38VS224 183CGSS	38VS260 183CGSS	38VS280 183CGSS	38VS335 183CGSS
380-415V/50Hz/3Ph, 380-415V/60Hz/3Ph								
4.5	5.0	6.0	6.5	7.0	8.0	9.0	10.0	12.0
12.5	14.0	16.0	18.0	20.0	22.4	26.0	28.0	33.5
42.7	47.8	54.6	61.4	68.2	76.4	88.7	95.5	114.3
6.4	7.0	8.2	8.1	9.9	11.1	13.3	13.4	17.7
3.76	4.16	4.88	4.81	5.87	6.57	7.88	7.95	10.50
3.32	3.37	3.28	3.74	3.41	3.41	3.30	3.52	3.19
8	8	9	9	10	10	13	16	19
50%~130%								
6000	6000	6000	6000	8000	8000	10000	10000	10000
10								
1								
Twin rotary								
DC								
2								
R410A								
3.5	3.8	3.8	4.2	5.3	5.3	6.1	8.0	8.0
975×1335×400			1015×1430×450			1120×1549×528		
86.6	86.6	90.1	94.7	112.7	112.7	130.0	144.0	144.0
56	56	56	59	59	59	62	62	62
100	100	100	100	100	100	120	120	120
30	30	30	30	30	30	30	30	30
20	20	20	20	20	20	20	20	20
Ø9.52	Ø9.52	Ø9.52	Ø9.52	Ø9.52	Ø9.52	Ø9.52	Ø12.7	Ø12.7
Ø15.88	Ø15.88	Ø15.88	Ø19.05	Ø19.05	Ø19.05	Ø22.2	Ø28.6	Ø28.6
-5~55								
16~32								

Modular Side-discharge VRF

Outdoor Units Lineup



Cooling Only Series



8-24HP

Capacity (HP)	8	10	12	14	16	18	20	22	24
Power supply	380~415V/50Hz/3Ph, 380~415V/60Hz/3Ph								
8	•								
10		•							
12			•						
14				•					
16					•				
18						•			
20							•		
22								•	
24									•
26			•	•					
28				••					
30				•	•				
32				•	••				
34				•			•		
36					•		•		
38						•	•		
40							••		
42							•	•	
44							••	••	
46								•	•
48								•	••
50				•	•		•		
52					••		•		
54					••			•	
56					••				•
58					•		•	•	
60							•••		
62							••	•	
64							•	••	
66								•••	
68								••	•
70								•	••
72									•••
74							•••	•	
76							••	••	
78							•	•••	
80								••••	
82								•••	•
84								••	••
86								•	•••
88								••••	
90								•••	•
92								••	••
94								•	•••
96									••••

High Efficiency

Twin Rotary DC Compressor

- **Twin rotary design**
At high rotational speeds, multiple cylinders ensure uniform compression and enable precise flow rate control through direct drive, achieving precision control down to 0.1 Hz.
- **Enhanced external compressor structure**
By optimizing the connection between the compressor body and the gas-liquid separator, vibrations are minimized, leading to improved operational stability.
- **Compact structure**
Reduced structural friction and vibration, low oil discharge, low noise, high stability and high efficiency.

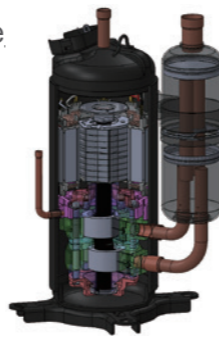

Brushless DC Motor

- The 3-phase DC motor balances power consumption, ensuring stable and efficient operation.
- Strong air flow, long distance up to 10m without duct.
- Maximum external static pressure up to 80Pa.*

Maximum
ESP
80Pa



* : Additional setting required at the outdoor unit to achieve maximum ESP 80Pa.

Inner-grooved Tube

The new copper tube with inner thread features an expanded surface area with the refrigerant, significantly enhancing the heat transfer efficiency.

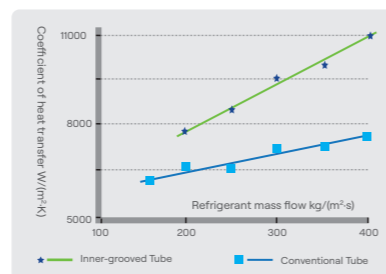
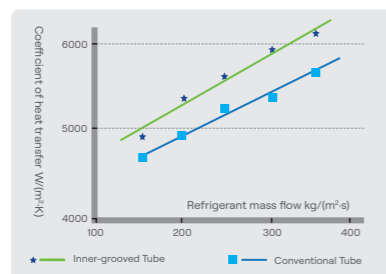
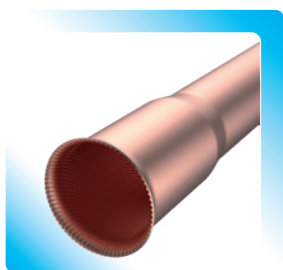

Incredible Flexibility

Long Refrigerant Piping

Total pipe length	560m
Height difference between indoor and outdoor unit	60m
Height difference between indoor units	20m

*Please refer to the installation manual for detailed length description.

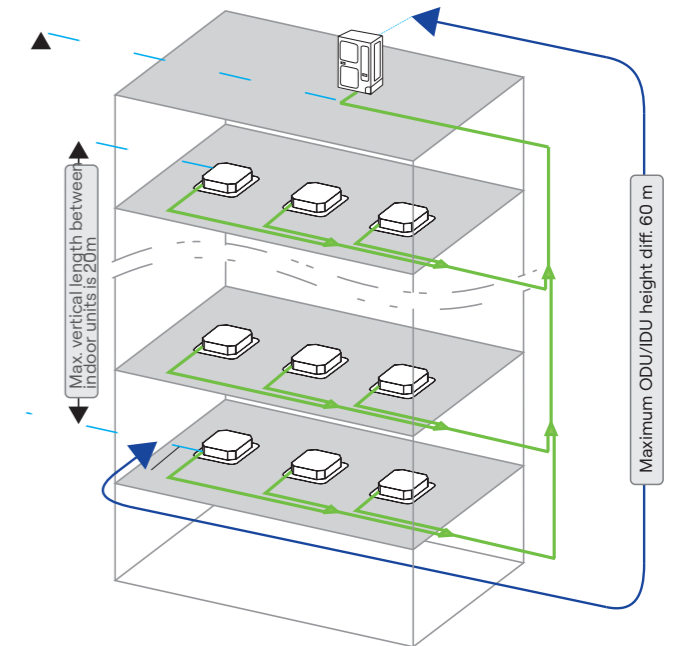

Small Footprint

The depth of modular side-discharge is only 570mm, which is 43% less than the top-discharge outdoor, require less space for installation and servicing.

Modular Top-discharge



96HP=24x4
Footprint: 5.4 m²

Modular Side-discharge



96HP=24x4
Footprint: 3.4 m²

Footprint
reduced by
37%

Ultimate Reliability

Back-up Running

If one module of the outdoor unit fails, other modules continue operating, maximising up time and user comfort.



Refrigerant Cooling Technology

The Carrier XCT8 keeps PCB cool with low-temperature refrigerant, delivering enhanced cooling stability even in high outdoor temperature.

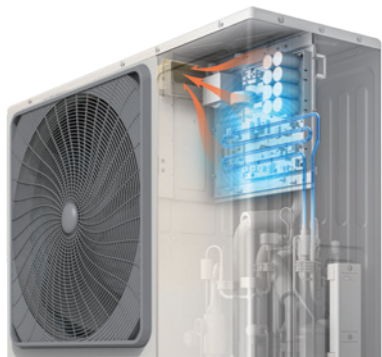

Digital Display

6-digit 7-segment digital tube display on PCB, shows system operation status and error codes.

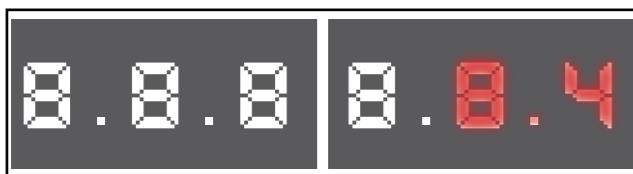

Ultimate Reliability

Reliable Multi-Layer Oil Return Technology

The advanced 6-stage oil return technology ensures consistent oil return to safeguard the compressor and maintain system reliability.

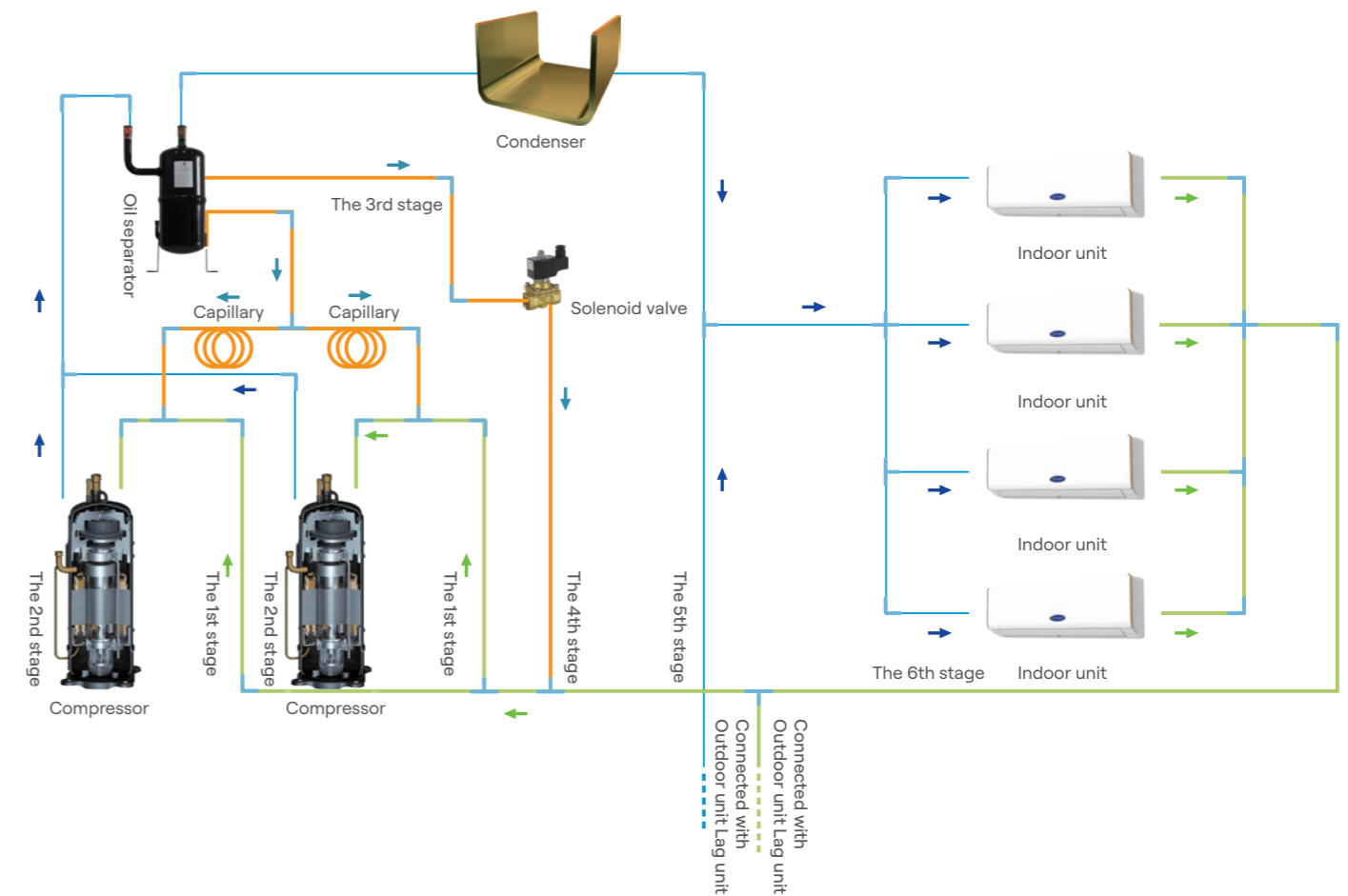

Wide Range of Options

Free Combination

- Single module from 8~24HP.
- Free combination with 4 modules, capacity up to 96HP.
- Connects up to 100 indoor units in one system.



Enhanced System Performance

Power Saving Mode

The outdoor unit offers 7 levels of adjustable power limit settings, reducing energy consumption while maintaining continuous system operation.

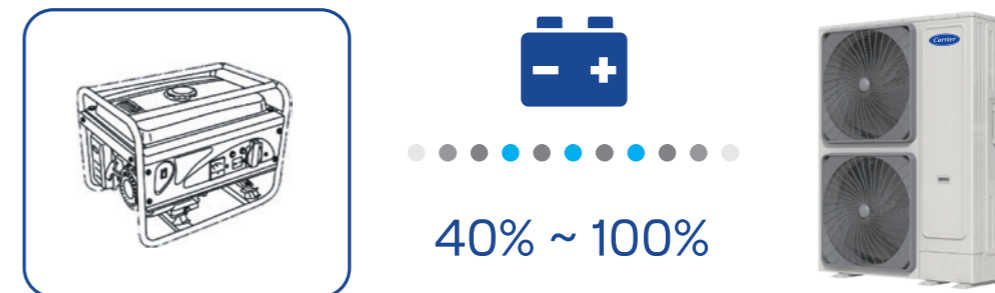

Large Operating Range

Wide Outdoor Temperature Operation Range

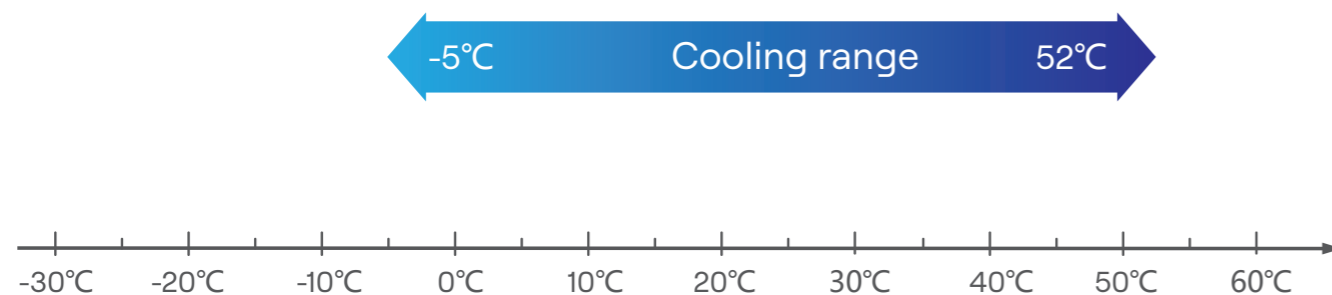

Intelligent Allocation of Capacity Technology

Intelligent load distribution is managed based on the outdoor unit operational status and refrigerant pipe pressure. When cooling demand reaches 85% of the unit capacity, the next module is automatically activated to ensure seamless performance.

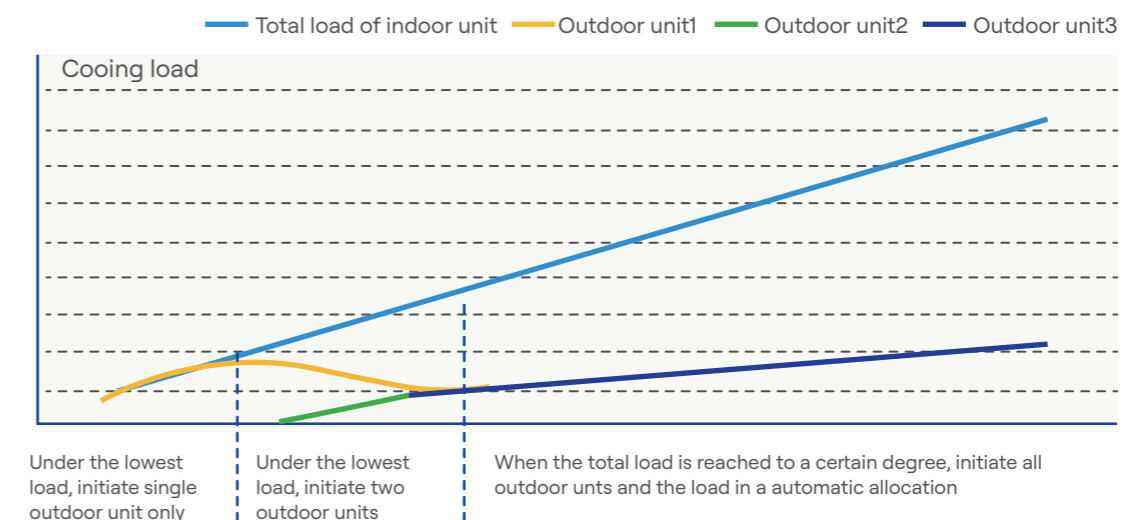

Easy Installation & Service

USB Port Available

USB port to support software update.

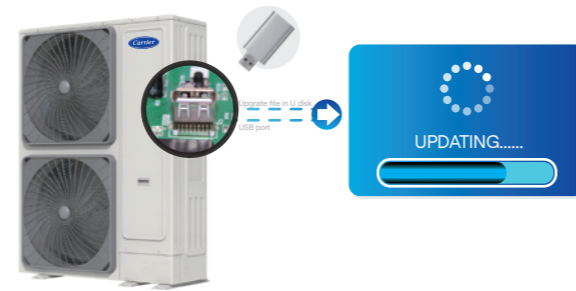

4 Directions Piping Connection

The outdoor unit's refrigerant piping supports four-directional extension, allowing flexible and versatile installation.

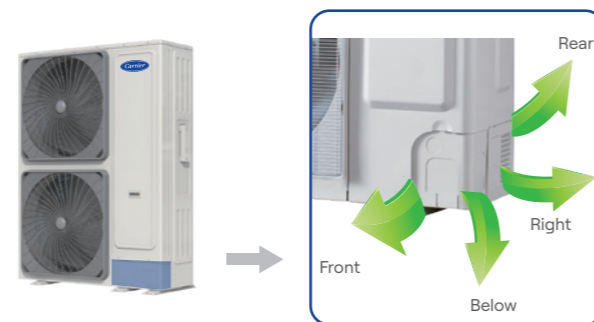

Maximum Operation Up Time

If one indoor unit experiences a failure and requires repair, it can be shut down individually while the remaining indoor units continue to operate normally.

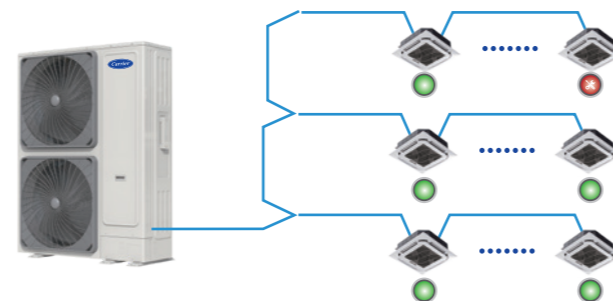

Error Code Log and Display

Engineered for easy maintenance and diagnostics, the outdoor unit features an integrated error code display and logging system with a history capacity of up to 64 error codes.

Easy Installation & Service

Doctor Kit

An advanced intelligent diagnostic and debugging software design for comprehensive diagnostics - enabling easy system testing and commissioning, and maintenance.

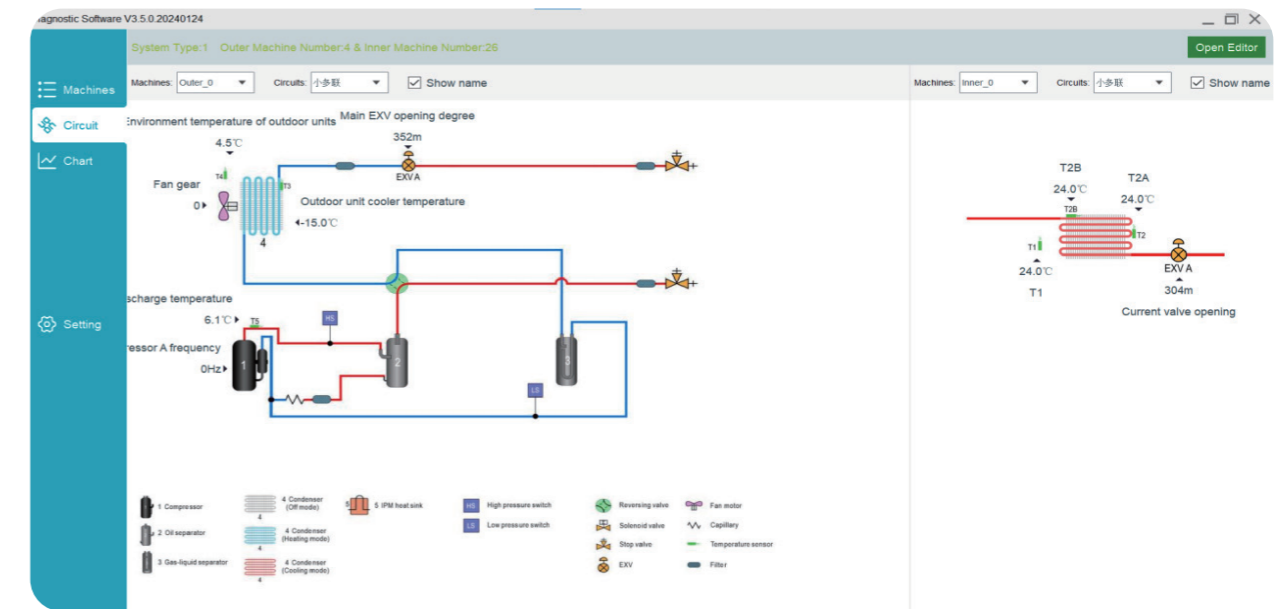

Installer Service Friendly



- 1 Access to electrical box maintenance through the removal of the front panel.
- 2 Features front and rear handles for convenient, and balanced lifting.
- 3 Easy access to charge valve for quick, safe and hassle-free maintenance.
 - Gas side stop valve • Liquid side stop valve • Repair needle valve

Enhanced User Comfort

Specifications

Night-time Noise Control

The compressor and fan motor are equipped with a low-noise operation mode, enabling a sound pressure level reduction of up to 8 dB(A) during night time operation.

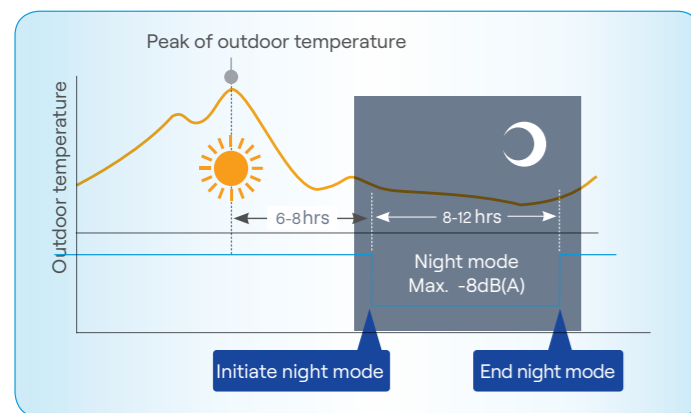

Setting	Night-mode Initiation from Peak Temperature	Night-mode Duration
Option 1 (Standard)	6 hours	10 hours
Option 2	8 hours	10 hours
Option 3	6 hours	12 hours
Option 4	8 hours	8 hours

Low Noise Design

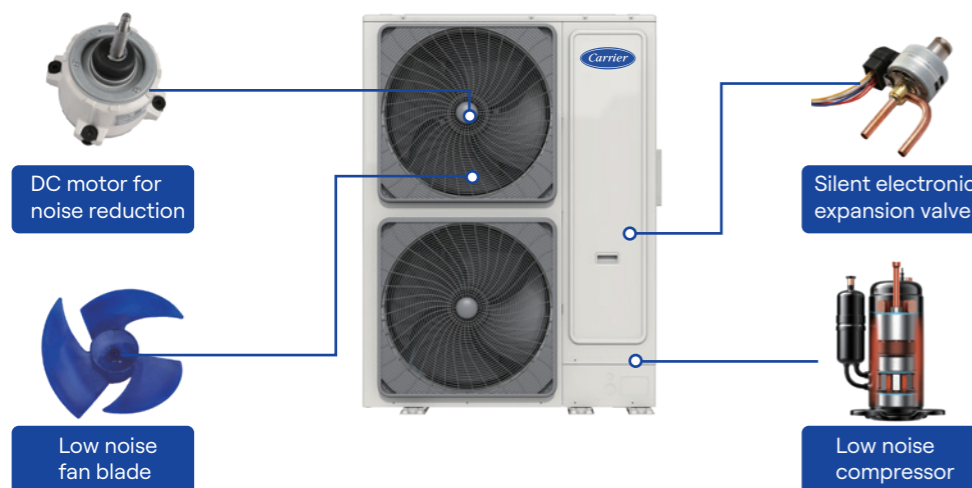

Modular Side-discharge VRF Series



8-24HP

Model	38VS008 M83CGSS	38VS010 M83CGSS	38VS012 M83CGSS	38VS014 M83CGSS	38VS016 M83CGSS	38VS018 M83CGSS	38VS020 M83CGSS	38VS022 M83CGSS	38VS024 M83CGSS			
Power supply	380~415V/50Hz/3Ph, 380~415V/60Hz/3Ph											
Cooling	Capacity	HP	8.0	10.0	12.0	14.0	16.0	18.0	20.0	22.0	24.0	
		kW	25.2	28.0	33.5	40.0	45.0	50.0	56.0	61.5	67.0	
	kBtu/h	86.0	95.5	114.3	136.5	153.5	170.6	191.1	209.8	228.6		
	Running current	A	8.2	9.5	12.2	15.2	17.8	20.5	23.2	25.8	29.5	
	Power input	kW	5.04	5.81	7.46	9.32	10.87	12.56	14.18	15.77	18.06	
EER	W/W	5.00	4.82	4.49	4.29	4.14	3.98	3.95	3.90	3.71		
Number of connectible indoor units	16	16	19	22	26	29	32	36	39			
Diversity ratio	80%~130%											
Airflow	m ³ /h	16500	16500	17500	18500	16500	16500	17500	18000	18000		
External static pressure	Pa	80*										
Compressor	Quantity	1										
	Type	Twin rotary										
Motor	Type	DC										
	Quantity	2										
Refrigerant	Type	R410A										
	Charging amount	kg	6.5	6.5	7.0	8.0	9.0	10.0	11.0	12.0	12.0	
Dimension(WxHxD)	mm	1320x1745x570										
Weight	kg	193	193	194	195	218	219	227	228	228		
Sound pressure level	dB(A)	57	57	58	59	60	61	61	63	63		
Refrigerant pipe	Total piping length	m	300	300	300	300	300	300	300	300		
	Height difference (Outdoor unit above)	m	50	50	50	50	50	50	50	50		
	Height difference (Outdoor unit below)	m	40	40	40	40	40	40	40	40		
	Liquid side	mm	Ø12.7	Ø12.7	Ø12.7	Ø12.7	Ø15.88	Ø15.88	Ø15.88	Ø15.88	Ø15.88	
	Gas side	mm	Ø28.6	Ø28.6	Ø28.6	Ø28.6	Ø28.6	Ø28.6	Ø28.6	Ø28.6	Ø28.6	
Cooling operation range	Outdoor unit	°C	-5~52									
	Indoor unit	°C	16~32									

Notes:
 1. Setting adjustment required at the outdoor unit. *
 2. The cooling conditions: indoor side 27°C(80.6°F) DB, 19°C(60°F)WB outdoor side 35°C(95°F) DB.
 3. Sound level: measured at a point 1 m in front of the unit at a height of 1.5 m. During actual operation, these values are normally somewhat higher as a result of ambient conditions.
 4. The above data may be changed without notice for future improvement on quality and performance.

Indoor Units Line-up



Indoor Units Line-up

Indoor unit		1-Way Cassette	2-Way Cassette	Compact Cassette	Round Way Cassette	High Wall	Vertical Duct	Floor Ceiling	Low Static Duct	Medium Static Duct	High Static Duct*	Free Static Duct	Fresh Air Processor*
Power supply (V/Hz/Ph)		220-240/50/1 208-230/60/1	220-240/50/1 208-230/60/1	220-240/50/1 208-230/60/1	220-240/50/1 208-230/60/1	220-240/50/1 208-230/60/1	220-240/50/1 208-230/60/1	208-230/60/1	220-240/50/1 208-230/60/1	220-240/50/1 208-230/60/1	220-240/50/1 208-230/60/1 208-230/60/3	220-240/50/1 208-230/60/1	220-240/50/1 208-230/60/1 380-415/50/3 208-230/60/3
Cap (kBTu/h)	Cap (kW)												
7.5	2.2	●		●		●			●				
9.6	2.8	●		●	●	●			●				
12.3	3.6	●		●	●	●		●	●				
15.4	4.5	●	●	●	●	●		●	●				
19.1	5.6	●	●		●	●		●	●				
24.2	7.1	●	●		●	●	●	●	●	●	●	●	
27.3	8.0		●		●			●		●	●	●	
30.7	9.0				●			●		●	●	●	
34.1	10.0				●		●	●		●	●	●	
38.2	11.2				●			●		●		●	
40.9	12.0										●		
42.7	12.5				●					●		●	
47.8	14.0				●			●		●		●	●
51.2	15.0									●	●		
54.6	16.0				●		●	●		●		●	
68.2	20.0										●		
67.4	22.4												●
85.3	25.0										●		
88.7	26.0										●		
95.5	28.0										●		●
119.4	35.0										●		
153.5	45.0										●		●
177.4	52.0										●		
191.1	56.0										●		●

*: Modular side-discharge outdoor unit could not match with high static duct(60Hz AC, 26~52kw and DC, 20~28kW) and fresh air processor.

High-Wall Features



Versatile application

- Retail shops
- Meeting rooms
- Small offices
- Security room

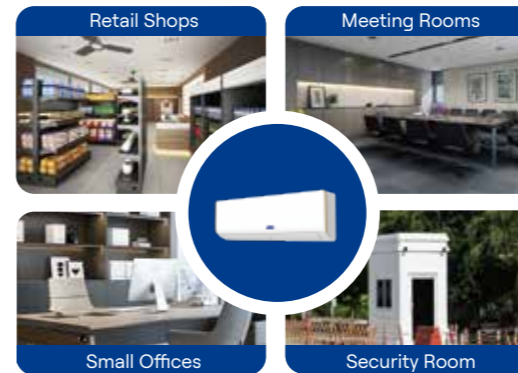

Wide angle airflow

- Large louver swing angle:
- Vertical airflow range 60°~90°
 - Horizontal airflow range 25°~140°

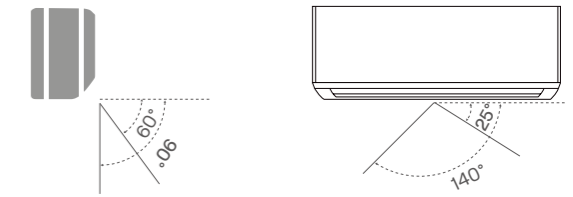

Flexible installation

Multi-direction piping connections provide versatile installation options to suit any layout.

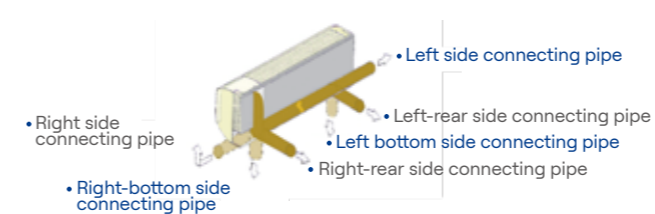

Washable filter

The long-life pre-filter can be easily removed from the air inlet grille for washing, helping maintain clean and healthy indoor air quality.

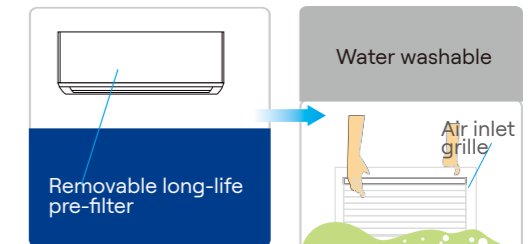

High-Wall

- Standard supply filter.
- 3D airflow distributes air evenly throughout a space.
- Flexible installation: refrigerant piping can be connected from 3 directions.
- Built-in key card function.
- Easy installation and maintenance.
- Whisper quiet performance, operating at noise level as low as 24 dB(A).



Standard supply	Optional	Optional	Optional
Wireless Remote Controller 40VC1518FGLY	Simple Wired Controller 40VCW618FGLY	Touch Key Wired Controller 40VCWT18FGLY	Touch Screen Wired Controller 40VCW518FGLY

Easy installation and maintenance

Easy-access panels, reach the wiring box with just one screw for efficient installation and hassle-free maintenance.



Key card integration

The High Wall units come equipped with integrated ON/OFF ports for the key card function, well suited for small hotels.

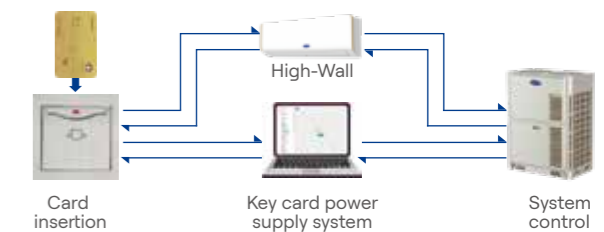

Specifications

1-Way Cassette

Model			40VK022S-8S-GSS	40VK028S-8S-GSS	40VK036S-8S-GSS	40VK045S-8S-GSS	40VK056S-8S-GSS	40VK071S-8S-GSS
Power supply			220~240V/50Hz/1Ph, 208~230V/60Hz/1Ph					
Cooling	Capacity	HP	0.8	1.0	1.3	1.6	2.0	2.5
		kW	2.2	2.8	3.6	4.5	5.6	7.1
		kBtu/h	7.5	9.6	12.3	15.4	19.1	24.2
	Running current	A	0.30	0.30	0.30	0.30	0.30	0.30
	Power input	W	10	10	13	15	18	28
Heating	Capacity	HP	0.9	1.1	1.4	1.8	2.3	2.9
		kW	2.6	3.2	4.0	5.0	6.3	8.0
		kBtu/h	8.9	10.9	13.6	17.1	21.5	27.3
	Running current	A	0.30	0.30	0.30	0.30	0.30	0.30
	Power input	W	10	10	13	15	18	28
Motor type			DC					
Airflow (Turbo/SH/H/M/ML/L/SL)		m ³ /h	440/380/380/360/360/340/340	440/380/380/360/360/340/340	500/440/440/420/410/400/380	650/600/600/580/560/540/520	720/650/650/620/580/570/560	890/800/780/750/720/680/650
Sound pressure level		dB(A)	24~33	24~33	28~34	28~34	33~40	35~44
Unit	Dimension (W×H×D)	mm	864×300×203			972×320×218		
	Weight	kg	10			12		
Refrigerant type			R410A					
Connection piping	Gas side	mm	Φ9.52	Φ9.52	Φ12.7	Φ12.7	Φ12.7	Φ15.88
	Liquid side	mm	Φ6.35	Φ6.35	Φ6.35	Φ6.35	Φ6.35	Φ9.52
Operation temperature	Cooling	°C	16~32					
	Heating	°C	16~32					



1-Way Cassette

- Standard supply filter.
- Built-in 700mm lift drain pump.
- Slim 250mm unit height*, ideal for tight ceiling spaces or low-clearance installations.
- Easily removable grilles allow convenient regular maintenance.
- Whisper quiet performance, operating at noise level as low as 27 dB(A).
- Wide angle airflow.

*: Selective capacities



Standard supply	Optional	Optional	Optional
Wireless Remote Controller 40VCI518FGLY	Simple Wired Controller 40VCW618FGLY	Touch Key Wired Controller 40VCWT18FGLY	Touch Screen Wired Controller 40VCW518FGLY

Features

Installation space

Featuring compact 250mm height*, designed for easy installation in tight or low-clearance spaces.

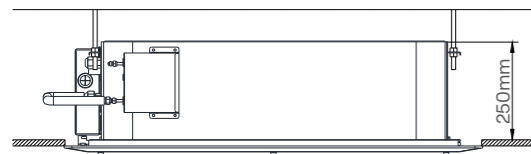

*: Selective capacities

Easy maintenance

Simply pull the lock catch to release the grille, allowing for easy removal during maintenance and cleaning.

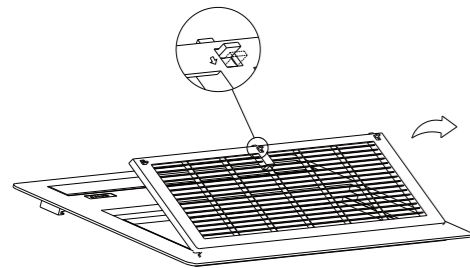

Versatile application

Creating more space around central area.



Wide angle airflow

Adjustable louver angle between 40° and 70° allows precise airflow control, enhancing comfort throughout the room.

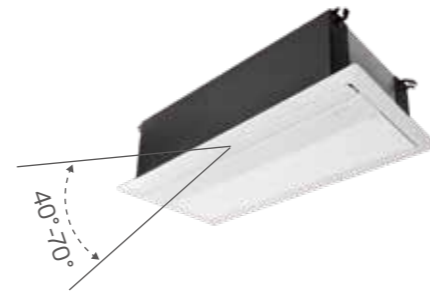

High lift drain pump

Built-in drain pump with 700mm lift, enabling flexible drainage piping design.

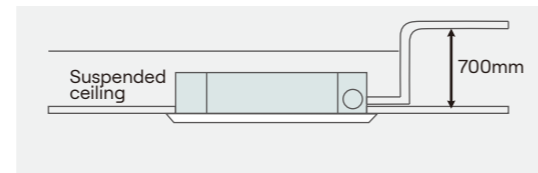

50Hz Specifications

Model		40VU0221P8K-GSS	40VU0281P8K-GSS	40VU0361P8K-GSS	40VU0451P8K-GSS	40VU0561P8K-GSS	40VU0711P8K-GSS	
Panel model		40VPU03618FGSS			40VPU07118FGSS			
Power supply		220~240V/50Hz/1Ph						
Cooling	Capacity	HP	0.8	1.0	1.3	1.6	2.0	2.5
		kW	2.2	2.8	3.6	4.5	5.6	7.1
		kBtu/h	7.5	9.6	12.3	15.4	19.1	24.2
	Running current	A	0.30	0.30	0.30	0.30	0.30	0.60
Power input	W	40	50	50	70	70	110	
Heating	Capacity	HP	0.9	1.1	1.4	1.8	2.3	2.9
		kW	2.6	3.2	4.0	5.0	6.3	8.0
		kBtu/h	8.9	10.9	13.6	17.1	21.5	27.3
	Running current	A	0.30	0.30	0.30	0.30	0.30	0.60
Power input	W	40	50	50	70	70	110	
Motor type		AC						
Airflow (H/M/L)	m ³ /h	420/290/270	500/340/290	500/340/290	800/670/500	800/670/500	1000/780/660	
Sound pressure level	dB(A)	27~35	28~38	28~38	33~40	33~40	37~46	
Unit	Dimension (W×H×D)	mm 985×250×513			mm 1295×290×553			
	Weight	kg 24.0			kg 35.5			
Panel	Dimension (W×H×D)	mm 1070×50×520			mm 1380×50×560			
	Weight	kg 3.6			kg 5.0			
Refrigerant type		R410A						
Connection piping	Gas side	mm	Φ9.52	Φ9.52	Φ12.7	Φ12.7	Φ12.7	Φ15.88
	Liquid side	mm	Φ6.35	Φ6.35	Φ6.35	Φ6.35	Φ6.35	Φ9.52
Operation temperature	Cooling	℃	16~32					
	Heating	℃	16~32					

60Hz Specifications 2-Way Cassette

Model			40VU0221P8L-GSS	40VU0281P8L-GSS	40VU0361P8L-GSS	40VU0451P8L-GSS	40VU0561P8L-GSS	40VU0711P8L-GSS
Panel model			40VPU03618FGSS			40VPU07118FGSS		
Power supply			208~230V/60Hz/1Ph					
Cooling	Capacity	HP	0.8	1.0	1.3	1.6	2.0	2.5
		kW	2.2	2.8	3.6	4.5	5.6	7.1
		kBtu/h	7.5	9.6	12.3	15.4	19.1	24.2
	Running current	A	0.30	0.30	0.30	0.30	0.30	0.60
	Power input	W	40	50	50	70	70	110
Heating	Capacity	HP	0.9	1.1	1.4	1.8	2.3	2.9
		kW	2.6	3.2	4.0	5.0	6.3	8.0
		kBtu/h	8.9	10.9	13.6	17.1	21.5	27.3
	Running current	A	0.30	0.30	0.30	0.30	0.30	0.60
	Power input	W	40	50	50	70	70	110
Motor type			AC					
Airflow (H/M/L)		m ³ /h	500/340/290			800/670/500	800/670/500	1000/780/660
Sound pressure level		dB(A)	28~38			33~40	33~40	37~46
Unit	Dimension (W×H×D)	mm	985×250×513			1295×290×553		
	Weight	kg	24.0			35.5		
Panel	Dimension (W×H×D)	mm	1070×50×520			1380×50×560		
	Weight	kg	3.6			5.0		
Refrigerant type			R410A					
Connection piping	Gas side	mm	Φ9.52	Φ9.52	Φ12.7	Φ12.7	Φ12.7	Φ15.88
	Liquid side	mm	Φ6.35	Φ6.35	Φ6.35	Φ6.35	Φ6.35	Φ9.52
Operation temperature	Cooling	°C	16~32					
	Heating	°C	16~32					



2-Way Cassette

- Standard supply filter.
- Built-in 700mm lift drain pump.
- Slim 315mm unit height, ideal for standard installations.
- Easily removable grilles allow for convenient regular maintenance.
- Low sound level, keep the comfort level with high efficiency.



Standard supply	Optional	Optional	Optional
Wireless Remote Controller 40VCI518FGLY	Simple Wired Controller 40VCW618FGLY	Touch Key Wired Controller 40VCWT18FGLY	Touch Screen Wired Controller 40VCW518FGLY

Features

Installation space

Featuring 315 mm height, designed for standard installations.

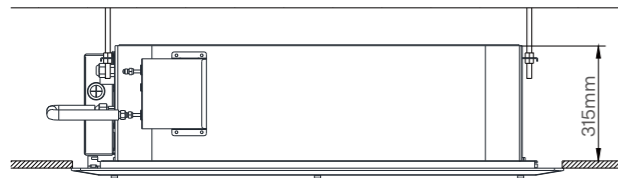

Easy maintenance

Simply pull the lock catch to release the grille, allowing for easy removal during maintenance and cleaning.

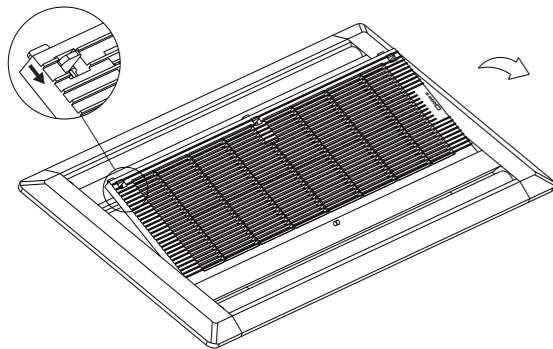

Wide angle airflow

Adjustable louver angle between 70° and 90° for improved control over airflow direction, enhancing comfort.



High lift drain pump

Built-in drain pump with 700mm lift, enabling flexible drainage piping design.

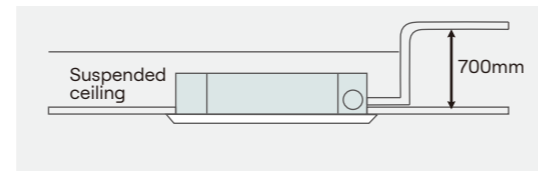

50Hz Specifications

Model			40VU0452P8K-GSS	40VU0562P8K-GSS	40VU0712P8K-GSS	40VU0802P8K-GSS
Panel model			40VPU05628FGSS		40VPU08028FGSS	
Power supply			220~240V/50Hz/1Ph			
Cooling	Capacity	HP	1.6	2.0	2.5	2.9
		kW	4.5	5.6	7.1	8.0
		kBtu/h	15.4	19.1	24.2	27.3
	Running current	A	0.45	0.45	0.60	0.60
Power input		W	80	80	110	110
Heating	Capacity	HP	1.8	2.3	2.9	3.2
		kW	5.0	6.3	8.0	9.0
		kBtu/h	17.1	21.5	27.3	30.7
	Running current	A	0.45	0.45	0.60	0.60
Power input		W	80	80	110	110
Motor type			AC			
Airflow (H/M/L)			750/610/530		1040/740/620	
Sound pressure level			34~43		35~46	
Unit	Dimension (W×H×D)	mm	1092×315×548		1332×315×548	
	Weight	kg	36.0		42.5	
Panel	Dimension (W×H×D)	mm	1178×44×630		1420×44×630	
	Weight	kg	5.0		6.5	
Refrigerant type			R410A			
Connection piping	Gas side	mm	Φ12.7	Φ12.7	Φ15.88	Φ15.88
	Liquid side	mm	Φ6.35	Φ6.35	Φ9.52	Φ9.52
Operation temperature	Cooling	°C	16~32			
	Heating	°C	16~32			

60Hz Specifications

Model			40VU0452P8L-GSS	40VU0562P8L-GSS	40VU0712P8L-GSS	40VU0802P8L-GSS
Panel model			40VPU05628FGSS		40VPU08028FGSS	
Power supply			208~230V/60Hz/1Ph			
Cooling	Capacity	HP	1.6	2.0	2.5	2.9
		kW	4.5	5.6	7.1	8.0
		kBtu/h	15.4	19.1	24.2	27.3
	Running current	A	0.45	0.45	0.60	0.60
	Power input	W	80	80	110	110
Heating	Capacity	HP	1.8	2.3	2.9	3.2
		kW	5.0	6.3	8.0	9.0
		kBtu/h	17.1	21.5	27.3	30.7
	Running current	A	0.45	0.45	0.60	0.60
	Power input	W	80	80	110	110
Motor type			AC			
Airflow (H/M/L)		m ³ /h	750/610/530		1040/740/620	
Sound pressure level		dB(A)	34~43		35~46	
Unit	Dimension (W×H×D)	mm	1092×315×548		1332×315×548	
	Weight	kg	36.0		42.5	
Panel	Dimension (W×H×D)	mm	1178×44×630		1420×44×630	
	Weight	kg	5.0		6.5	
Refrigerant type			R410A			
Connection piping	Gas side	mm	Φ12.7	Φ12.7	Φ15.88	Φ15.88
	Liquid side	mm	Φ6.35	Φ6.35	Φ9.52	Φ9.52
Operation temperature	Cooling	°C	16~32			
	Heating	°C	16~32			

Compact Cassette



Compact Cassette

- Standard supply filter.
- Built-in 700mm lift drain pump.
- Slim 267mm unit height, deal for tight ceiling spaces or low-clearance installations.
- Perfectly suited for 600×600mm ceiling board installations.
- Quiet performance - operating at noise level as low as 28 dB(A).
- Reserved fresh air inlet to improve indoor air quality.



Standard supply	Optional	Optional	Optional
Wireless Remote Controller 40VCI518FGLY	Simple Wired Controller 40VCW618FGLY	Touch Key Wired Controller 40VCWT18FGLY	Touch Screen Wired Controller 40VCW518FGLY

Features

Installation space

With a compact 650mm width casing, the unit fits seamlessly into standard ceiling board layouts, ideal choice for small offices and meeting rooms.



LED display

- Set temperature
- Operating status
- Error codes



Compact and slim body design

Featuring slim 267mm height, designed for easy installation in tight or low-clearance spaces.

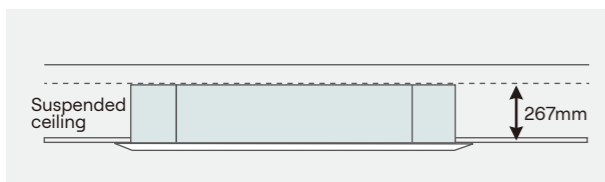

Reserved fresh air intake

The indoor unit has reserved fresh air inlet for introducing fresh air* to improve the indoor air quality.



*: Recommended fresh air volume at 10%~15% of the indoor unit's air volume.

Easy maintenance

Simply pull the lock catch to release the grille, allowing for easy removal during maintenance and cleaning.



Built-in drain pump

Built-in drain pump with 700mm lift, enabling flexible drainage piping design.

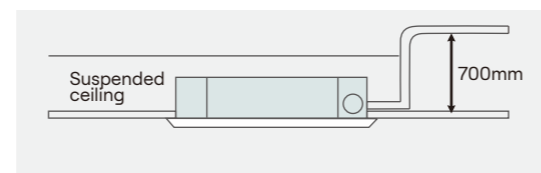

Specifications

Model		40VU022C-8S-GSS	40VU028C-8S-GSS	40VU036C-8S-GSS	40VU045C-8S-GSS	
Panel model		40VPU045C8SGLY				
Power supply		220~240V/50Hz/1Ph, 208~230V/60Hz/1Ph				
Cooling	Capacity	HP	0.8	1.0	1.3	1.6
		kW	2.2	2.8	3.6	4.5
		kBtu/h	7.5	9.6	12.3	15.4
	Running current	A	0.38	0.38	0.38	0.38
Power input		W	20	20	30	30
Heating	Capacity	HP	0.9	1.1	1.4	1.8
		kW	2.5	3.2	4.0	5.0
		kBtu/h	8.5	10.9	13.6	17.1
	Running current	A	0.38	0.38	0.38	0.38
Power input		W	20	20	30	30
Motor type		DC				
Airflow (H/M/L)		m ³ /h		440/320/240	530/430/320	
Sound pressure level		dB(A)		28~35	32~40	
Unit	Dimension (W×H×D)	mm				653×267×585
	Weight	kg				17.5
Panel	Dimension (W×H×D)	mm				650×30×650
	Weight	kg				2.7
Refrigerant type		R410A				
Connection piping	Gas side	mm	Φ9.52	Φ9.52	Φ12.7	Φ12.7
	Liquid side	mm	Φ6.35	Φ6.35	Φ6.35	Φ6.35
Operation temperature	Cooling	°C	16~32			
	Heating	°C	16~32			

Round Way Cassette



Features

Airflow distribution

Engineered with an 8-way airflow panel, the system ensures even air circulation that reaches every corner of the room without blind spots. This design enables consistent temperature distribution, enhancing overall comfort and efficiency.



Installation space

Featuring slim height from 232 to 286mm, designed for easy installation in tight or low-clearance spaces.

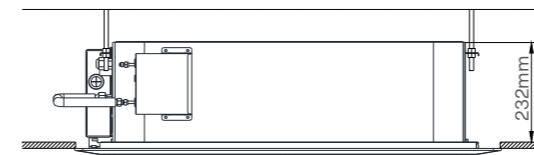

Digital display

- Set temperature
- Operating status
- Error codes

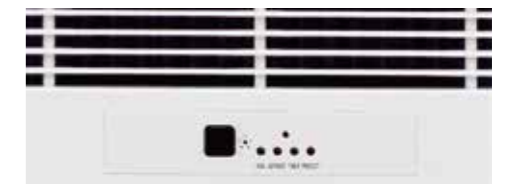

Fresh air intake

The indoor unit has reserved fresh air inlet for introducing fresh air* to improve the indoor air quality. Duct connections can be configured on any side of the unit, offering flexible airflow extension to adjacent spaces.



*: Recommended fresh air volume at 10%~15% of the indoor unit's air volume.

Round Way Cassette

- Standard supply filter.
- Built-in 1200mm lift drain pump.
- 8 way airflow for better air distribution.
- Featuring slim 232mm height*, designed for easy installation in tight or low-clearance spaces.
- Quiet performance - operating at noise level as low as 30 dB(A).
- Reserved fresh air inlet to improve indoor air quality.



Standard supply	Optional	Optional	Optional
Wireless Remote Controller 40VC1518FGLY	Simple Wired Controller 40VCW618FGLY	Touch Key Wired Controller 40VCWT18FGLY	Touch Screen Wired Controller 40VCW518FGLY

*: Selective capacities

Applications

Perfect for open office layouts, retail shops, classroom, lobby and indoor spaces requiring uniform air distribution.



Built-in drain pump

Built-in drain pump with 1200mm lift, enabling flexible drainage piping design.

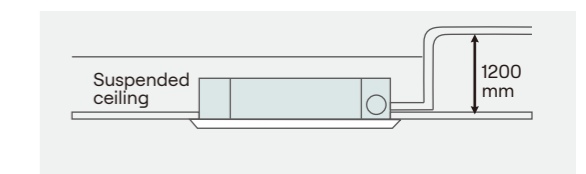

Specifications

Model			40VU028 RP8S-GSS	40VU036 RP8S-GSS	40VU045 RP8S-GSS	40VU056 RP8S-GSS	40VU071 RP8S-GSS	40VU080 RP8S-GSS
Panel model			40VPU160R8DGSC					
Panel mode (Philippines model)			40VPU160R8S-GSS					
Power supply			220~240V/50Hz/1Ph, 208~230V/60Hz/1Ph					
Cooling	Capacity	HP	1.0	1.3	1.6	2.0	2.5	2.9
		kW	2.8	3.6	4.5	5.6	7.1	8.0
		kBtu/h	9.6	12.3	15.4	19.1	24.2	27.3
	Running current	A	0.67	0.67	0.67	0.67	0.67	1.26
	Power input	W	25	30	30	30	65	65
Heating	Capacity	HP	1.1	1.4	1.8	2.3	2.9	3.2
		kW	3.2	4.0	5.0	6.3	8.0	9.0
		kBtu/h	10.9	13.6	17.1	21.5	27.3	30.7
	Running current	A	0.67	0.67	0.67	0.67	0.67	1.26
	Power input	W	25	30	30	30	65	65
Motor type			DC					
Airflow (H/M/L)		m ³ /h	750/700/650	810/730/660	810/730/660	810/730/660	1200/1050/750	1200/1050/750
Sound pressure level		dB(A)	30~36	31~38	31~38	31~38	34~39	34~39
Unit	Dimension (W×H×D)	mm	900×232×833					
	Weight	kg	21.5	23.0	23.0	23.0	23.0	23.0
Panel	Dimension (W×H×D)	mm	1030×100×1030					
	Weight	kg	6.0					
Refrigerant type			R410A					
Connection piping	Gas side	mm	Φ9.52	Φ12.7	Φ12.7	Φ12.7	Φ15.88	Φ15.88
	Liquid side	mm	Φ6.35	Φ6.35	Φ6.35	Φ6.35	Φ9.52	Φ9.52
Operation temperature	Cooling	℃	16~32					
	Heating	℃	16~32					

Specifications

		40VU090 RP8S-GSS	40VU100 RP8S-GSS	40VU112 RP8S-GSS	40VU125 RP8S-GSS	40VU140 RP8S-GSS	40VU160 RP8S-GSS
		40VPU160R8DGSC					
		40VPU160R8S-GSS					
		220~240V/50Hz/1Ph, 208~230V/60Hz/1Ph					
		3.2	3.6	4.0	4.5	5.0	5.7
		9.0	10.0	11.2	12.5	14.0	16.0
		30.7	34.1	38.2	42.7	47.8	54.6
		1.26	1.26	1.26	1.26	1.26	1.26
		70	70	70	100	100	100
		3.6	4.0	4.5	5.4	5.7	6.4
		10.0	11.2	12.5	15.0	16.0	18.0
		34.1	38.2	42.7	51.2	54.6	61.4
		1.26	1.26	1.26	1.26	1.26	1.26
		70	70	70	100	100	100
		DC					
		1400/1200/950			1700/1450/1150		
		35~41			40~47		
		900×286×833					
		28.5					
		1030×100×1030					
		6.0					
		R410A					
		Φ15.88					
		Φ9.52					
		16~32					
		16~32					

Floor-Ceiling



Floor-Ceiling

- Standard supply filter.
- Panel with digital display.
- Flexible installation.
- Suitable for retail application.
- 3D airflow distribution.
- Built-in electronic expansion valve.
- Optional external drain pump, with 700mm lift.



Standard supply	Optional	Optional	Optional
Wireless Remote Controller 40VCI518FGLY	Simple Wired Controller 40VCW618FGLY	Touch Key Wired Controller 40VCWT18FGLY	Touch Screen Wired Controller 40VCW518FGLY

Features

Digital display

- Set temperature
- Operating status
- Error codes



Flexible installation

Versatile installation depending on the room layout, ceiling height and airflow needs.

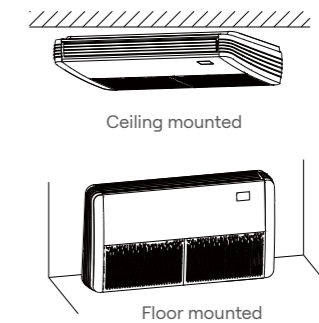

Easy installation and maintenance

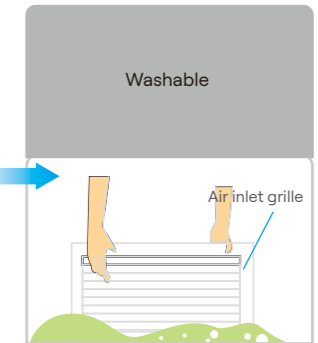
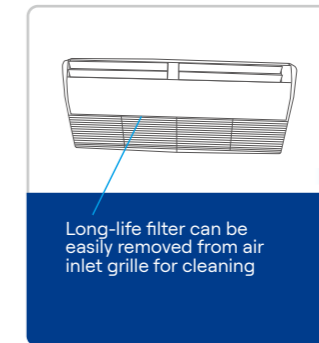
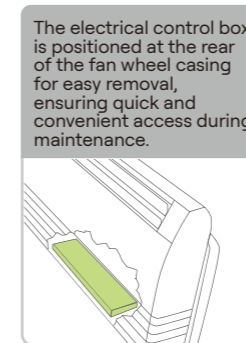
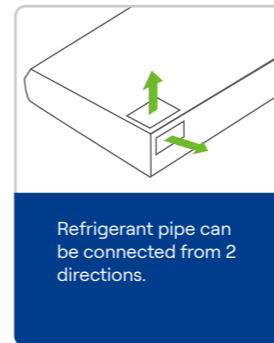

3D airflow distribution

Vertical airflow range 67° ~90° and horizontal airflow range 5°~115°. recommended for application: convenience stores, restaurants.

Configured with low noise high performance centrifugal fans which delivers high airflow and long distance air supply.

3 dimensional air supply with a wide supply angle, ensuring consistent air distribution to every corner of the room.

In cooling mode, cold air is discharged horizontally to naturally create an evenly cooled environment. In heating mode, warm air is directed vertically downward to quickly and efficiently warm the space from the ground up.

Specifications

Model			40VC036F-8S-GSS	40VC045F-8S-GSS	40VC056F-8S-GSS
Power supply			220~240V/50Hz/1Ph, 208~230V/60Hz/1Ph		
Cooling	Capacity	HP	1.3	1.6	2.0
		kW	3.6	4.5	5.6
		kBtu/h	12.3	15.4	19.1
	Running current	A	1.33	1.33	1.33
	Power input	W	20	20	30
Heating	Capacity	HP	1.4	1.8	2.3
		kW	4.0	5.0	6.3
		kBtu/h	13.6	17.1	21.5
	Running current	A	1.33	1.33	1.33
	Power input	W	20	20	30
Motor type			DC		
Airflow (H/M/L)		m ³ /h	550/490/460	550/490/460	690/550/490
Sound pressure level		dB(A)	35~40	35~40	35~43
Unit	Dimension (W×H×D)	mm	1050×675×235		
	Weight	kg	26.0		
Refrigerant type			R410A		
Connection piping	Gas side	mm	Φ12.7		
	Liquid side	mm	Φ6.35		
Operation temperature	Cooling	℃	16~32		
	Heating	℃	16~32		

Specifications

40VC071F-8S-GSS	40VC080F-8S-GSS	40VC090F-8S-GSS	40VC112F-8S-GSS	40VC140F-8S-GSS	40VC160F-8S-GSS
220~240V/50Hz/1Ph, 208~230V/60Hz/1Ph					
2.5	2.9	3.2	4.0	5.0	5.7
7.1	8.0	9.0	11.2	14.0	16.0
24.2	27.3	30.7	38.2	47.8	54.6
1.00	1.00	2.66	2.66	2.66	2.66
40	40	60	60	130	130
2.9	3.2	3.6	4.5	5.7	6.4
8.0	9.0	10.0	12.5	16.0	18.0
27.3	30.7	34.1	42.7	54.6	61.4
1.00	1.00	2.66	2.66	2.66	2.66
40	40	60	60	130	130
DC					
1000/930/870	1000/930/870	1400/1280/1190	1400/1280/1190	1920/1620/1280	1920/1620/1280
42~46	42~46	42~48	42~48	43~53	43~53
1300×675×235	1300×675×235	1670×675×235			
31.5	31.5	39.0	39.0	41.0	41.0
R410A					
Φ15.88					
Φ9.52					
16~32					
16~32					

Low Static Duct



Features

Slim design

With a compact unit height of just 210mm, the Low Static Duct fits into ceiling spaces as low as 220mm, making it an ideal solution for hotel rooms, small offices, and meeting rooms.

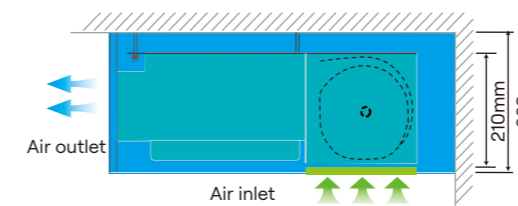

Built-in drain Pump

Built-in drain pump with 700mm lift, enabling flexible drainage piping design.

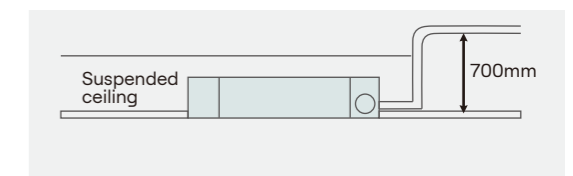

Low noise

The DC brushless motor lowers energy consumption and operational noise - as low as 24 dB(A).



High efficiency low noise motor, motor and support frame with rubber ring isolation, can absorb vibration and reduce noise.

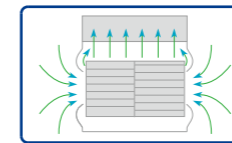

Air inlet of fan wheel casing is arch curved design; it can reduce air flow's disturbance, make airflow smoother to reduce noise.

PM2.5 filter (Optional)

Advanced PM2.5 filter is available for cleaner, healthier air.



Low Static Duct

- Standard supply filter.
- Standard ESP 30Pa. Adjustable to Maximum ESP 50Pa.
- Flexible installation with air return from rear or bottom.
- Featuring slim 210mm height, designed for easy installation in tight or low-clearance spaces.
- Quiet performance, operating at noise level as low as 24 dB(A).
- Built-in drain pump with maximum 700mm lift.



Optional	Optional	Optional	Optional
Wireless Remote Controller 40VCI518FGLY 40VICR18FGLY (receiver)	Simple Wired Controller 40VCW618FGLY	Touch Key Wired Controller 40VCWT18FGLY	Touch Screen Wired Controller 40VCW518FGLY

Flexible installation of return air duct

The return air duct supports rear or bottom inlet configuration, allowing flexible installation based on the available space and site requirements.

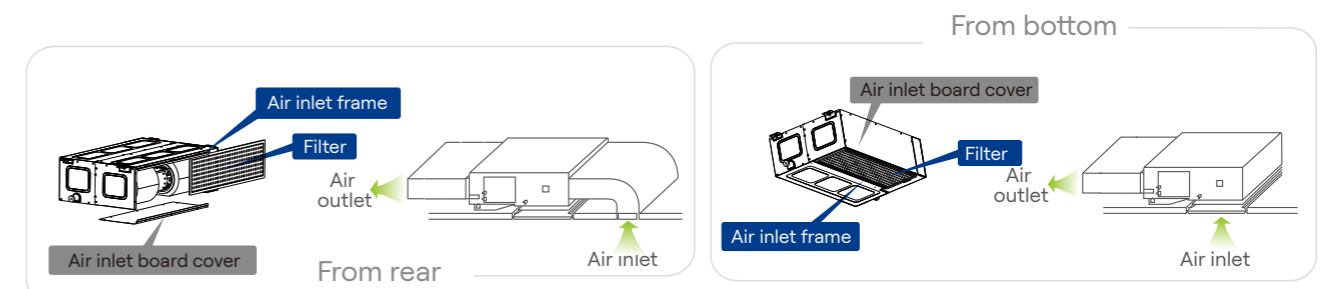

Specifications

Model			40VD022 MP8S-GSS	40VD028 MP8S-GSS	40VD036 MP8S-GSS	40VD045 MP8S-GSS	40VD056 MP8S-GSS	40VD071 MP8S-GSS	
Power supply			220~240V/50Hz/1Ph, 208~230V/60Hz/1Ph						
Cooling	Capacity	HP	0.8	1.0	1.3	1.6	2.0	2.5	
		kW	2.2	2.8	3.6	4.5	5.6	7.1	
		kBtu/h	7.5	9.6	12.3	15.4	19.1	24.2	
	Running current	A	0.60	0.60	0.60	0.60	0.66	0.88	
	Power input	W	20	20	30	35	45	55	
Heating	Capacity	HP	0.9	1.1	1.4	1.8	2.3	2.9	
		kW	2.5	3.2	4.0	5.0	6.3	8.0	
		kBtu/h	8.5	10.9	13.6	17.1	21.5	27.3	
	Running current	A	0.60	0.60	0.60	0.60	0.66	0.88	
	Power input	W	20	20	30	35	45	55	
Motor type			DC						
Airflow (Turbo/SH/H/M/ML/L/SL)		m³/h	450/390/310/230/160/150/145		550/470/360/250/160/155/150		740/620/510/330/160/150/145		1050/980/860/750/630/490/330
External static pressure		Pa	0~30						
Sound pressure level		dB(A)	24~29	24~29	25~32	32~37	28~38	30~39	
Unit	Dimension (W×H×D)	mm	814x210x467	814x210x467	814x210x467	814x210x467	1010x210x467	1214x210x467	
	Weight	kg	19.0	19.0	19.5	19.5	22.5	28.0	
Refrigerant type			R410A						
Connection piping	Gas side	mm	Φ9.52	Φ9.52	Φ12.7	Φ12.7	Φ12.7	Φ15.88	
	Liquid side	mm	Φ6.35	Φ6.35	Φ6.35	Φ6.35	Φ6.35	Φ9.52	
Operation temperature	Cooling	°C	16~32						
	Heating	°C	16~32						

Medium Static Duct



Medium Static Duct

- Standard supply filter.
- Standard ESP 30Pa. Adjustable to Maximum ESP 70Pa.
- Flexible installation with air return from rear or bottom.
- Built-in drain pump with 1200mm lift.
- 7 steps airflow.
- Reserved inlet for fresh air duct connection.



Optional	Optional	Optional	Optional
Wireless Remote Controller 40VC1518FGLY 40VC1818FGLY (receiver)	Simple Wired Controller 40VCW618FGLY	Touch Key Wired Controller 40VCWT18FGLY	Touch Screen Wired Controller 40VCW518FGLY

Free Static Duct



Free Static Duct

- Standard supply filter.
- Adaptive ESP from 0 to 200 Pa.
- Built-in drain pump with 1200mm lift.
- Flexible installation: reserved drainage pipe connection either left or right side.
- Quiet performance, operating at noise level as low as 31 dB(A).
- Reserved inlet for fresh air duct connection.



Optional	Optional	Optional	Optional
Wireless Remote Controller 40VCI518FGLY 40VCI18FGLY (receiver)	Simple Wired Controller 40VCW618FGLY	Touch Key Wired Controller 40VCWT18FGLY	Touch Screen Wired Controller 40VCW518FGLY

Medium & Free ESP Static Features

Integration with interior design

- Free static duct with variable ESP designed to specific needs. Choices of duct available depending on maximum ESP required: Medium static duct up to 70Pa, and Free static duct up to 200Pa.
- Flexible installation with air return from rear or bottom.

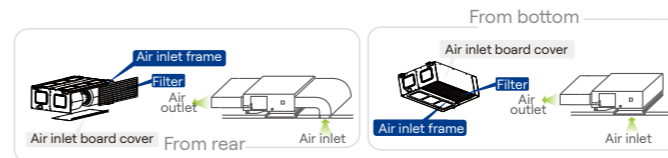

Built-in drain pump

Built-in drain pump with 1200mm lift, enabling flexible drainage piping design.

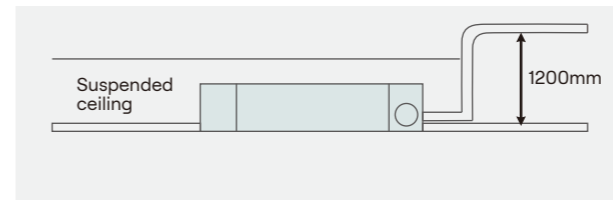

Flexible drainage pipe installation

Reserved drainage outlet holes are available on both the left and right sides, allowing on-site selection for flexible pipe installation.

Low noise

The DC brushless motor lowers energy consumption and operational noise, as low as 31 dB(A).

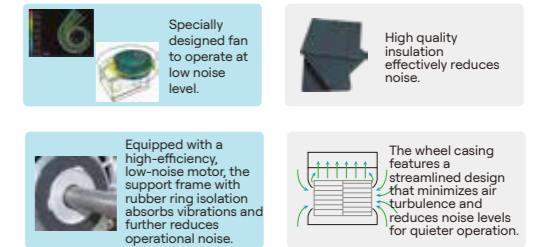

Note: 33dB(A) for Medium ESP Duct and 31dB(A) for Free ESP Duct.

Reserved fresh air intake

The indoor unit has reserved fresh air inlet for introducing fresh air* to improve the indoor air quality.

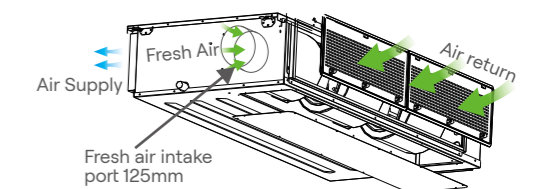

*: Recommended fresh air volume at 10% of the indoor unit's air volume.

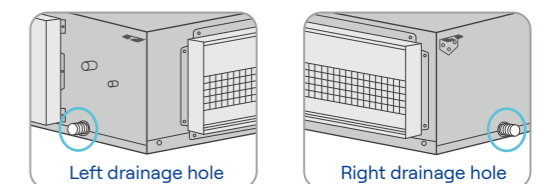

Adaptive external static pressure*

- Adaptive static pressure can be easily configured via the wired controller.
- Adaptive static pressure control ensures consistent airflow without attenuation, automatically adjusting to maintain optimal performance under varying duct conditions.

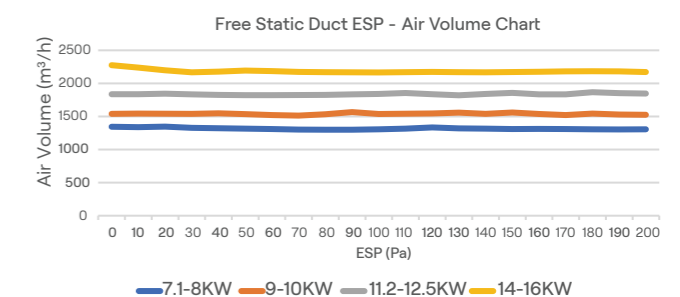

*: Free static duct unit

Medium Static Duct Specifications

Model		40VD071 GP8S-GSS	40VD080 GP8S-GSS	40VD090 GP8S-GSS	40VD100 GP8S-GSS	40VD112 GP8S-GSS	40VD125 GP8S-GSS	40VD140 GP8S-GSS	40VD150 GP8S-GSS	40VD160 GP8S-GSS	
Power supply		220~240V/50Hz/1Ph, 208~230V/60Hz/1Ph									
Cooling	Capacity	HP	2.5	2.9	3.2	3.6	4.0	4.5	5.0	5.4	5.7
		kW	7.1	8.0	9.0	10.0	11.2	12.5	14.0	15.0	16.0
		kBtu/h	24.2	27.3	30.7	34.1	38.2	42.7	47.8	51.2	54.6
	Running current	A	1.90	1.90	1.90	1.90	1.90	2.50	2.50	2.50	2.50
	Power input	W	85	85	110	135	135	175	270	270	270
Heating	Capacity	HP	2.9	3.2	3.6	4.0	4.5	5.0	5.7	6.1	6.4
		kW	8.0	9.0	10.0	11.2	12.5	14.0	16.0	17.0	18.0
		kBtu/h	27.3	30.7	34.1	38.2	42.7	47.8	54.6	58.0	61.4
	Running current	A	1.90	1.90	1.90	1.90	1.90	2.50	2.50	2.50	2.50
	Power input	W	85	85	110	135	135	175	270	270	270
Motor type		DC									
Airflow (Turbo/H/M/L)	m ³ /h	1200/1000/ 900/750		1350/ 1150/1050/ 830		1450/1250/ 1150/900		1850/ 1650/1550/ 1150		2200/1850/1700 /1350	
External static pressure	Pa	0~70									
Sound pressure level	dB(A)	33~37	33~37	34~39	34~41	34~41	35~44	38~48	38~48	38~48	
Unit	Dimension (W×H×D)	1200×267×740					1437×267×740				
	Weight	kg	31.0	31.0	31.0	32.0	32.0	39.0	39.0	39.0	40.5
Refrigerant type		R410A									
Connection piping	Gas side	mm					Φ15.88				
	Liquid side	mm					Φ9.52				
Operation temperature	Cooling	°C					16~32				
	Heating	°C					16~32				

Free Static Duct Specifications

Model		40VD071 HP8S-GSS	40VD080 HP8S-GSS	40VD090 HP8S-GSS	40VD100 HP8S-GSS	40VD112 HP8S-GSS	40VD125 HP8S-GSS	40VD140 HP8S-GSS	40VD160 HP8S-GSS		
Power supply		220~240V/50Hz/1Ph, 208~230V/60Hz/1Ph									
Cooling	Capacity	HP	2.5	2.9	3.2	3.6	4.0	4.5	5.1	5.7	
		kW	7.1	8.0	9.0	10.0	11.2	12.5	14.0	16.0	
		kBtu/h	24.2	27.3	30.7	34.1	38.2	42.7	48.5	54.6	
	Running current	A	1.35	1.35	1.65	1.65	2.11	2.11	2.88	2.88	
	Power input	W	133	133	158	158	220	220	359	359	
Heating	Capacity	HP	2.9	3.2	3.6	4.0	4.5	5.0	5.7	6.3	
		kW	8.0	9.0	10.0	11.2	12.5	14.0	16.0	17.5	
		kBtu/h	27.3	30.7	34.1	38.2	42.7	47.8	54.6	59.7	
	Running current	A	1.35	1.35	1.65	1.65	2.11	2.11	2.88	2.88	
	Power input	W	133	133	158	158	220	220	359	359	
Motor type		DC									
Airflow (H/M/L)	m ³ /h	1350/1100/950			1550/1250/1080			1850/1550/1250		2200/1850/1550	
External static pressure	Pa	0~200									
Sound pressure level	dB(A)	31~41	31~41	31~42	31~42	34~44	34~44	39~48	39~48		
Unit	Dimension (W×H×D)	1200×267×740				1437×267×740					
	Weight	kg	34.0	34.0	40.0	40.0	40.0	40.0	41.5	41.5	
Refrigerant type		R410A									
Connection piping	Gas side	mm					Φ15.88				
	Liquid side	mm					Φ9.52				
Operation temperature	Cooling	°C					16~32				
	Heating	°C					16~32				

High Static Duct (50Hz AC) High Static Duct (60Hz AC)



High Static Duct (50Hz AC)

- Standard supply filter.*
- High ESP up to 200 Pa.
- Optional external drain pump available.*
- 10~20HP are not compatible with modular side-discharge unit.

*: Selective capacities



Optional	Optional	Optional	Optional
Wireless Remote Controller 40VCI518FGLY 40VCIR18FGLY (receiver)	Simple Wired Controller 40VCW618FGLY	Touch Key Wired Controller 40VCWT18FGLY	Touch Screen Wired Controller 40VCW518FGLY

High Static Duct (60Hz AC)

- Standard supply filter.*
- High ESP up to 250Pa.
- Optional external drain pump available.*
- 10~20HP are not compatible with modular side-discharge unit.

*: Selective capacities



Optional	Optional	Optional	Optional
Wireless Remote Controller 40VCI518FGLY 40VCIR18FGLY (receiver)	Simple Wired Controller 40VCW618FGLY	Touch Key Wired Controller 40VCWT18FGLY	Touch Screen Wired Controller 40VCW518FGLY

High Static Duct (DC)



High Static Duct (DC)

- Standard supply filter.
- Reserved inlet for fresh air duct connection.
- High ESP up to 150 Pa.*
- 10HP is not compatible with modular side-discharge unit.

*: Via dip switch setting



Optional	Optional	Optional	Optional
Wireless Remote Controller 40VC1518FGLY 40VCIR18FGLY (receiver)	Simple Wired Controller 40VCW618FGLY	Touch Key Wired Controller 40VCWT18FGLY	Touch Screen Wired Controller 40VCW518FGLY

Features

Optional drain pump

Drain pump with up to 700 mm lift is available as accessory.*

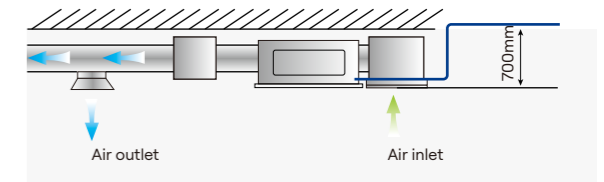

Flexible drain pipe installation

Drain outlets are reserved on both the left and right sides, providing flexibility for efficient drain pipe installation.*

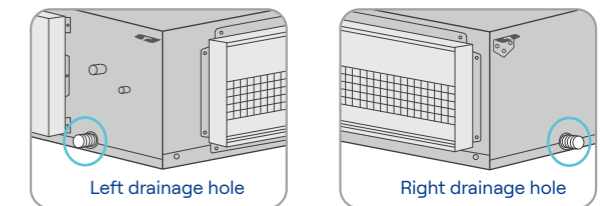

*: Selective capacities

High static pressure

With high static pressure up to 250 Pa, this unit is ideal for high-ceiling and large spaces. It seamlessly integrates with various air diffusers to enhance air distribution and elevate interior aesthetics.

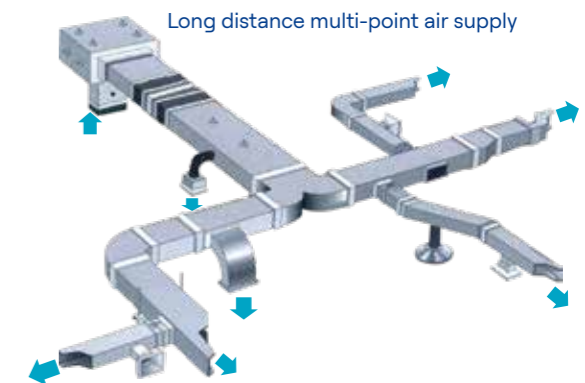
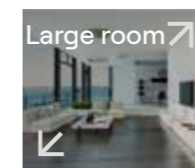
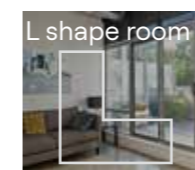
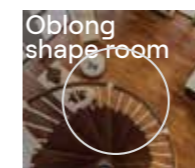

Note: For 40VD450H-8C-GSS/40VD560H-8C-GSS, 40VD350H-89-GSS/40VD520H-89-GSS

• If the 20HP high static pressure duct unit's capacity \geq 80% of the indoor unit system total capacity: Only duct units connectable, system connection ratio 115%~130%.

• If the 20HP high static pressure duct unit's capacity $<$ 80% of the indoor unit system total capacity: All VRF indoor units connectable, system connection ratio 50%~130%.

High Static Duct (50Hz AC) Specifications

High Static Duct (50Hz AC) Specifications

Model			40VD071H-8K-GSS	40VD080H-8K-GSS	40VD090H-8K-GSS	40VD100H-8K-GSS	40VD125H-8K-GSS
Power supply			220~240V/50Hz/1Ph				
Cooling	Capacity	HP	2.5	2.9	3.2	3.6	4.3
		kW	7.1	8.0	9.0	10.0	12.0
		kBtu/h	24.2	27.3	30.7	34.1	40.9
	Running current	A	2.00	2.00	2.00	2.80	2.80
	Power input	W	400	400	400	500	500
Heating	Capacity	HP	2.9	3.2	3.6	4.0	5.4
		kW	8.0	9.0	10.0	11.2	15.0
		kBtu/h	27.3	30.7	34.1	38.2	51.2
	Running current	A	2.00	2.00	2.00	2.80	2.80
	Power input	W	400	400	400	500	500
Motor type			AC				
Airflow (H/M/L)		m ³ /h	1000/840/770			2300/1700/1400	
External static pressure		Pa	120				
Sound pressure level		dB(A)	40~42			40~47	
Unit	Dimension (W×H×D)	mm	1445×260×680			1190×370×620	
	Weight	kg	46			47	
Refrigerant type			R410A				
Connection piping	Gas side	mm	Φ15.88				
	Liquid side	mm	Φ9.52				
Operation temperature	Cooling	°C	16~32				
	Heating	°C	16~32				

40VD150H-8K-GSS	40VD200H-8K-GSS	40VD250H-8K-GSS	40VD280H-8K-GSS	40VD450H-8C-GSS	40VD560H-8C-GSS
220~240V/50Hz/1Ph				380~415V/50Hz/3Ph	
5.4	7.1	8.9	10.0	16.1	20.0
15.0	20.0	25.0	28.0	45.0	56.0
51.2	68.2	85.3	95.5	153.5	191.1
2.80	6.00	6.00	6.00	4.80	4.80
500	1720	1720	1720	2600	3400
6.1	7.9	9.8	11.1	17.9	22.5
17.0	22.0	27.5	31.0	50.0	63.0
58.0	75.1	93.8	105.8	170.6	215.0
2.80	6.00	6.00	6.00	4.80	4.80
500	1720	1720	1720	2600	3400
AC					
2300/1700/1400	4200/3600/2900			6000	8000
120				200	200
40~47	45~55			60	64
1190×370×620	1440×448×811			2165×676×916	
47	102			222	
R410A					
Φ15.88	Φ22.2			Φ28.6	
Φ9.52	Φ12.7			Φ15.88	
16~32					
16~32					

High Static Duct (60Hz AC) Specifications

High Static Duct (60Hz AC) Specifications

Model			40VD071H-8L-GSS	40VD080H-8L-GSS	40VD090H-8L-GSS	40VD100H-8L-GSS	40VD125H-8L-GSS	40VD150H-8L-GSS	
Power supply			208~230V/60Hz/1Ph						
Cooling	Capacity	HP	2.5	2.9	3.2	3.6	4.3	5.4	
		kW	7.1	8.0	9.0	10.0	12.0	15.0	
		kBtu/h	24.2	27.3	30.7	34.1	40.9	51.2	
	Running current	A	2.00	2.00	2.00	2.80	2.80	2.80	
	Power input	W	400	400	400	500	500	500	
Heating	Capacity	HP	2.9	3.2	3.6	4.0	5.4	6.1	
		kW	8.0	9.0	10.0	11.2	15.0	17.0	
		kBtu/h	27.3	30.7	34.1	38.2	51.2	58.0	
	Running current	A	2.00	2.00	2.00	2.80	2.80	2.80	
	Power input	W	400	400	400	500	500	500	
Motor type			AC						
Airflow (H/M/L)	m ³ /h	1000/840/770			2300/1700/1400				
External static pressure	Pa	120							
Sound pressure level	dB(A)	40~42			40~47				
Unit	Dimension (W×H×D)	mm	1445×260×680			1190×370×620			
	Weight	kg	46			47			
Refrigerant type			R410A						
Connection piping	Gas side	mm	Φ15.88						
	Liquid side	mm	Φ9.52						
Operation temperature	Cooling	°C	16~32						
	Heating	°C	16~32						

40VD200H-8L-GSS	40VD250H-8L-GSS	40VD260H-8L-GSS	40VD280H-8L-GSS	40VD350H-89-GSS	40VD520H-89-GSS
208~230V/60Hz/1Ph				208~230V/60Hz/3Ph	
7.1	8.9	9.3	10.0	12.5	18.6
20.0	25.0	26.0	28.0	35.0	52.0
68.2	85.3	88.7	95.5	119.4	177.4
6.00	6.00	6.00	6.00	4.80	8.40
1720	1720	1620	1720	1930	3500
7.9	9.8	10.2	11.1	13.8	20.4
22.0	27.5	28.6	31.0	38.5	57.2
75.1	93.8	97.6	105.8	131.4	195.2
6.00	6.00	6.00	6.00	4.80	8.40
1720	1720	1720	1720	1930	3500
AC					
4200/3300/2700			4200/3300/2700		7500
120			200		250
45~55			45~55		63
1440×448×811			1440×448×811		2165×676×916
102			100		217
R410A					
Φ22.2				Φ28.6	
Φ12.7				Φ15.88	
16~32					
16~32					

High Static Duct (DC) Specifications

Model			40VD200H-8S-GSS	40VD250H-8S-GSS	40VD280H-8S-GSS
Power supply			220~240V/50Hz/1Ph, 208~230V/60Hz/1Ph		
Cooling	Capacity	HP	7.1	8.9	10.0
		kW	20.0	25.0	28.0
		kBtu/h	68.2	85.3	95.5
	Running current	A	3.40	3.40	3.40
	Power input	W	1200	1200	1300
Heating	Capacity	HP	7.9	9.8	11.0
		kW	22.0	27.5	30.8
		kBtu/h	75.1	93.8	105.1
	Running current	A	3.40	3.40	3.40
	Power input	W	1200	1200	1300
Motor type			DC		
Airflow (H/M/L)		m ³ /h	3900/3650/2800	3900/3650/2800	4200/3650/2800
External static pressure		Pa	100 (50~150)		
Sound pressure level		dB(A)	45~50	46~51	48~52
Unit	Dimension (W×H×D)	mm	1440×448×811		
	Weight	kg	102		
Refrigerant type			R410A		
Connection piping	Gas side	mm	Φ22.2		
	Liquid side	mm	Φ12.7		
Operation temperature	Cooling	℃	16~32		
	Heating	℃	16~32		

Vertical Duct



Vertical Duct

- Standard supply filter.
- Insulated Cabinet: Minimize heat loss while preventing condensation.
- Strong airflow.
- Dual-orientation installation: supports vertical and horizontal installation with customizable airflow direction.



Optional	Optional	Optional	Optional
Wireless Remote Controller 40VCI518FGLY 40VCIR18FGLY (receiver)	Simple Wired Controller 40VCW618FGLY	Touch Key Wired Controller 40VCWT18FGLY	Touch Screen Wired Controller 40VCW518FGLY

Features

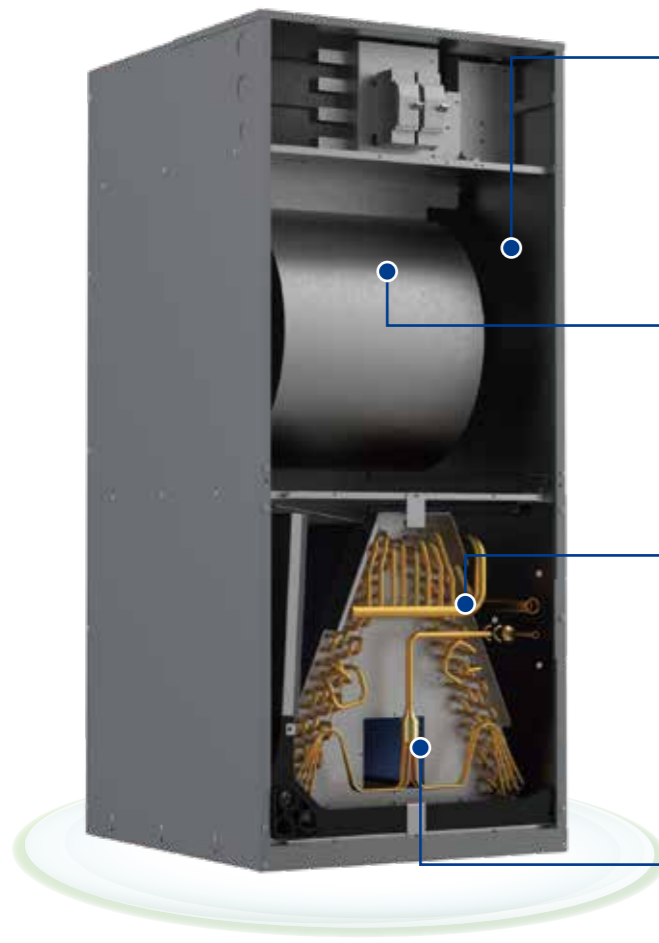

Insulated cabinet
All panels are constructed from galvanized steel and finished with a durable paint coating. Internal surfaces are fully lined with thermal insulation to minimize heat loss, while preventing condensation.

Motor & blower
5-step speed control for varying cooling needs.

A-Shape heat exchanger
"A" shape coils, constructed with inner groove copper tube and hydrophilic aluminum foil to provide efficient heat exchange.

Expansion device
Built-in electronic expansion valve.

Washable filter

Washable filter is available as accessory to provide cleaner and healthier air.

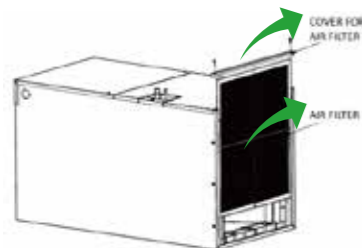

Dual-orientation installation

Installation orientation can be customized to accommodate site-specific spatial constraints and airflow requirements. In addition to flexible vertical or horizontal position, the airflow direction can be customised, enabling 4 different configurations.

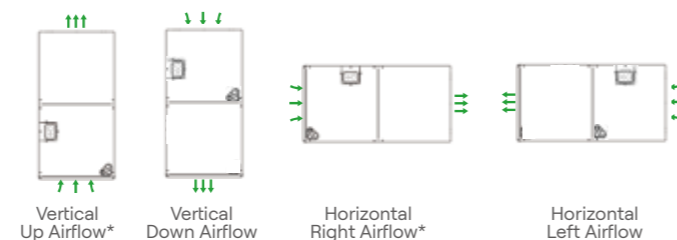

*: Customisation required

Specifications

Model		40VD071N-8L-GSS	40VD105N-8L-GSS	40VD160N-8L-GSS	
Power supply		208-230V/60Hz/1Ph			
Cooling	Capacity	HP	2.5	3.8	5.7
		kW	7.1	10.5	16.0
		kBtu/h	24.2	35.8	54.6
	Running current	A	1.1	1.1	2.5
Power input	W	290	290	517	
Heating	Capacity	HP	2.9	4.1	6.4
		kW	8.0	11.5	18.0
		kBtu/h	27.3	39.2	61.4
	Running current	A	1.1	1.1	2.5
Power input	W	290	290	517	
Motor type		AC			
Airflow (H/M/L)		m ³ /h	1500/1500/1250	1500/1500/1250	2500/2500/2300
External static pressure		Pa	25	25	50
Sound pressure level		dB(A)	51~54	51~54	57~60
Unit	Dimension (W×H×D)	mm	460×520×774	460×520×774	500×550×970
	Weight	kg	36	36	48
Refrigerant type		R410A			
Connection piping	Gas side	mm	Φ15.88		
	Liquid side	mm	Φ9.52		
Operation temperature	Cooling	°C	16~32		
	Heating	°C	16~32		

Fresh Air Processor



Features

Innovative air supply technology

A Fresh air processing unit can be used in combination with other indoor units in a single XCT8 VRF system, enabling fresh air intake along with cooling / heating of indoor spaces.

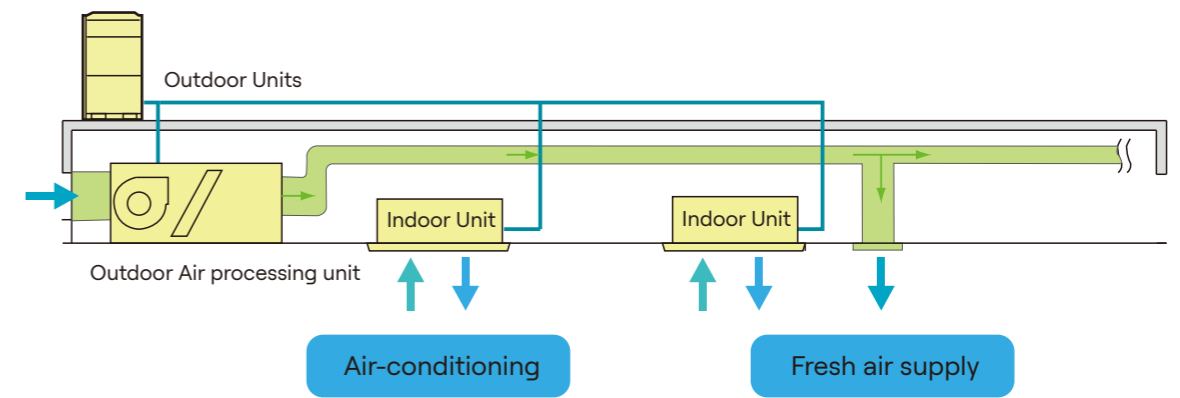

Notes:

- When the system connects only to fresh air units, total capacity must not exceed 100% of the system capacity; no quantity limit applies.
- When fresh air units are mixed with VRF indoor units: total indoor capacity (all units) must stay 50%~100% of the system capacity, and fresh air unit capacity must not exceed 30% of total indoor capacity.
- Not compatible with modular side-discharge unit.

Fresh Air Processor

- Standard supply filter.*
- Creates a healthy and comfortable environment.
- High external static pressure: maximum static pressure up to 300Pa.
- Wide capacity range: from 14kW to 56kW.
- Flexible system design: both fresh air filtration and heating/cooling in a single system.
- Flexible installation: standalone or mixed combination with other indoor units.



Optional	Optional	Optional	Optional
Wireless Remote Controller 40VCI518FGLY 40VICR18FGLY (receiver)	Simple Wired Controller 40VCW618FGLY	Touch Key Wired Controller 40VCWT18FGLY	Touch Screen Wired Controller 40VCW518FGLY

*: Selective capacities

Comfortable environment

Introducing fresh air to replace indoor air can help reduce airborne pathogens and other contaminants - creating a healthier indoor environment.



High external static pressure

External static pressure up to 300Pa for more flexible duct applications.

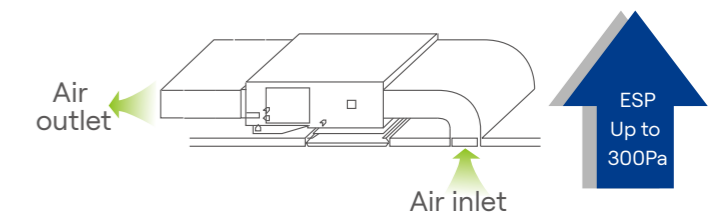

Specifications

Model			40VD140A-8K-GSS	40VD224A-8K-GSS	40VD280A-8K-GSS	40VD450A-8C-GSS	40VD560A-8C-GSS
Power supply			220~240V/50Hz/1Ph			380~415V/50Hz/3Ph	
Cooling	Capacity	HP	5.0	8.0	10.0	16.1	20.0
		kW	14.0	22.4	28.0	45.0	56.0
		kBtu/h	47.8	76.4	95.5	153.5	191.1
	Running current	A	2.80	6.00	6.00	4.80	4.80
	Power input	W	450	800	800	1300	2000
Heating	Capacity	HP	3.6	5.7	7.1	11.2	13.9
		kW	10.0	16.0	20.0	31.4	39.0
		kBtu/h	34.1	54.6	68.2	107.1	133.1
	Running current	A	2.80	6.00	6.00	4.80	4.80
	Power input	W	450	800	800	1300	2000
Motor type			AC				
Airflow (H/M/L)		m ³ /h	2100/1500/1100	2500	2800/2400	4000	6000
External static pressure		Pa	196	200	220	300	300
Sound pressure level		dB(A)	42~48	48	45~52	58	62
Unit	Dimension (W×H×D)	mm	1190×370×620	1440×448×811	1440×448×811	2165×676×916	2165×676×916
	Weight	kg	47	102	102	222	222
Refrigerant type			R410A				
Connection piping	Gas side	mm	Φ15.88	Φ22.2	Φ22.2	Φ28.6	Φ28.6
	Liquid side	mm	Φ9.52	Φ12.7	Φ12.7	Φ15.88	Φ15.88
Operation temperature	Cooling	°C	16~32				
	Heating	°C	16~32				

Specifications

40VD140A-8L-GLY	40VD224A-8L-GLY	40VD280A-8L-GLY	40VD450A-89-GLY	40VD560A-89-GLY
208~230V/60Hz/1Ph			208~230V/60Hz/3Ph	
5.0	8.0	10.0	16.1	20.0
14.0	22.4	28.0	45.0	56.0
47.8	76.4	95.5	153.5	191.1
2.80	6.00	6.00	4.80	8.40
450	800	800	1930	3500
3.6	5.7	7.1	11.2	13.9
10.0	16.0	20.0	31.4	39.0
34.1	54.6	68.2	107.1	133.1
2.80	6.00	6.00	4.80	8.40
450	800	800	1930	3500
AC				
2100/1500/1100	2700	3100/2500	6300	9000
196	200	220	300	300
42~48	48	45~52	63	67
1190×370×620	1440×448×811	1440×448×811	2165×676×916	2165×676×916
47	100	100	217	237
R410A				
Φ15.88	Φ22.2	Φ22.2	Φ28.6	Φ28.6
Φ9.52	Φ12.7	Φ12.7	Φ15.88	Φ15.88
16~32				
16~32				

Wide Choices of Indoor Units

Key card function

Every indoor unit is equipped with an integrated on/off port for smart room card functionality with energy-saving standby and quick-recovery functions.

Auto addressing

The PCB comes with a default automatic addressing feature, reduces errors and manual work.

Power-down memory

The PCB comes with power-down memory as a standard feature. Upon rebooting after a power outage, it will resume operation based on the last settings prior to the shutdown.

Sleep mode

The set temperature automatically adjusts by 1 degree Celsius per hour upon Sleep Mode activation, with maximum change of 2 degree Celsius - ensuring a comfortable sleep environment and energy savings.

IFEEL

Press and hold the 'ECO' button on the remote control to activate this function. It enables real-time room temperature monitoring by transmitting data from the remote control's built-in sensor to the indoor unit every 3 minutes, ensuring accurate ambient temperature detection and enhanced energy efficiency.



Type	Filter	Drain pump	Reserved fresh air intake	Fan speed	Airflow (Louver)
1-Way cassette	YES	YES (700mm)	NO	3	Vertical
2-Way cassette	YES	YES (700mm)	NO	3	Vertical
Compact cassette	YES	YES (700mm)	YES	3	Vertical
Round way cassette	YES	YES (1200mm)	YES	3	Vertical
Low static duct	YES (PM2.5 optional)	YES (700mm)	NO	7	/
Middle static duct	YES	YES (1200mm)	YES	7	/
Free static duct	YES	YES (1200mm)	YES	3	/
High static duct (DC)	YES	NO	NO	3	/
High static duct (50Hz, AC)	Yes (For 7.1-28kW)	Optional (For 7.1-15kW)	Yes (For 7.1-9kW)	3	/
High static duct (60Hz, AC)	Yes (For 7.1-28kW)	Optional (For 7.1-15kW)	Yes (For 7.1-9kW)	3	/
Fresh air processor	Yes (For 14-28 kW) Optional (For 45-56 kW)	NO	NO	3	/
Vertical duct	YES	NO	NO	3	/
Floor-ceiling	YES	NO	NO	3	Vertical/Horizontal
High-wall	YES	NO	NO	3	Vertical/Horizontal

Controller Line-up



Controller Line-up

Controller Type	Picture	Model
Remote Controller		Wireless remote controller: 40VCI518FGLY Remote control receiver: 40VICIR18FGLY
Individual Wired Controller		Touch key wired controller 40VCWT18FGLY
		Simple wired controller 40VCW618FGLY
		Touch screen wired controller 40VCW518FGLY
Central Controller		Simple central controller 40VCC418FGLY
		Touch screen central controller 40VCC718FGLY
C-Box		40VCCW38FGLY
Network Central Controller		40VCC518FGLY-128 40VCC518FGLY-256 40VCC518FGLY-512 40VCC518FGLY-1024
	Electricity meter	SP-D120
BMS Gateway		BACnet: 40VCBB18FGLY
		Modbus: 40VCBM18FGLY

Controller Line-up

Item	Wireless Remote Controller	Simple Wired Controller	Touch Key Wired Controller	Touch Screen Wired Controller	
Model	40VCI518FGLY	40VCW618FGLY	40VCWT18FGLY	40VCW518FGLY	
Dimension (WxHxD) (mm)	41x185x26	86x86x21.5	86x86x16.5	86x86x18.1	
Picture					
Power Supply	Battery	12V-DC	12V-DC	12V-DC	
Connectivity	Max. Controllable Indoor Units	1	4	4	
	Max. Groups Controllable	1	1	1	
Basic Control Function	On/Off	•	•	•	
	Mode Setting (Auto-Heat-Cool-Dry-Fan)	•	•	•	
	Fan Speed (Auto-Low-Mid-High)	•	•	•	
	Temperature Setting	•	•	•	
	Airflow Direction --Up&Down	•	•	•	
	Airflow Direction --Left&Right	•	•	•	
	Temperature Control	+/-1°C	+/-0.5°C	+/-0.5°C	+/-0.5°C
	°F/°C	•	•	•	•
Display	Set-point Temperature	•	•	•	
	Real Time Clock	/	/	/	
	Date	/	/	/	
	Indoor Unit Status Display	/	•	•	
	Backlight	/	•	/	
Advanced Function	Child Lock	•	•	•	
	Eco	•	/	•	
	IFEEL	•	•	•	
	Sleep	•	•	•	
	Turbo	•	•	•	
	Control Lock (Under Central Controller)	•	•	•	
	Screen Saver	/	/	/	
	Screen Brightness Adjustment	/	/	/	
Schedule/Timer	Timer On/Off	•	•	•	
	Weekly Schedule	/	/	/	
Installer Info.	Error Code Display	/	•	•	

Controller Line-up

Item		Simple Central Controller	Touch Screen Central Controller	C-Box	Network Central Controller			
Model		40VCC418FGLY	40VCC718FGLY	40VCCW38FGLY	40VCC518 FGLY-128	40VCC518 FGLY-256	40VCC518 FGLY-512	40VCC518 FGLY-1024
Dimension (WxHxD) (mm)		120x120x31	177x112x47	78x66x25	179x109x65			
Picture								
Power Supply		12V-DC	12V-DC	12V-DC	12V-DC			
Connectivity	Max. Controllable Indoor Units	100	100	100	128	256	512	128
	Max. Outdoor Unit System (Max. Gateway#)	No limit	No limit	No limit	15	30	60	15
Screen	Screen Type	TFT LCD	TFT LCD	Mobile phone	Computer			
	Screen Dimension	/	/	Mobile phone	Computer			
	Button Type	Button	Touch Screen	keyButton	Computer			
	Backlight	•	•	/	/			
	Screen Saver	•	•	/	/			
Display	Screen Brightness Adjustment	/	•	/	/			
	Room Air/ Set Temperature	•	•	•	•			
	Time, Day and Date	/	•	•	•			
	°F/°C Switch	/	•	/	/			
Standard Control Function	General Indoor Unit status display	•	•	•	•			
	On/Off	•	•	•	•			
	Mode (Auto-Cool-Dry-Heat-Fan)	•	•	• (No Auto)	•			
	Temperature Setting	•	•	•	•			
	Temperature Control	+/-1	+/-1	+/-1	+/-1			
Central Control	Fan Speed (Auto-Low-Mid-High)	•	•	•	•			
	Group (zone) control	/	•	•	•			
	One Button On/Off	•	/	/	/			
	Group (Zone) Name Setting	/	•	•	•			
Schedule	Group (Zone) Name Display	/	•	•	•			
	Daily	/	•	•	•			
	Weekly	/	•	•	•			
Electricity Data Management	Number of Schedule Programs	/	10	No limit	No limit			
	Electricity Bill	/	Current meter readings	/	•			
	Electricity Fee Charge	/	/	/	•			
	Electricity Peak, Valley and Flat Setting	/	/	/	•			
Advanced Function	Historical Electricity Data	/	/	/	•			
	Control mode (LIFO/Central/Lock)	LIFO/Lock	LIFO/Lock	LIFO/Lock	LIFO/Lock			
	ECO	/	•	•	/			
	Unit/Groups Setting	/	•	•	•			
	Indoor Unit No. Display	•	•	/	•			
	Unit Running Time Display	/	/	/	•			
	Indoor Unit Parameter Display	/	•	•	•			
	Operation mode (Cooling only/Heat only/No limit)	•	•	•	•			
	Floor Layout (Floor Navigation)	/	/	/	•			
	Control Lock	•	•	/	•			
	Set Temperature Limit	/	•	/	/			
	WIFI Module	/	•	•	/			
Installer Information	Device refresh	/	•	•	/			
	Error Code	•	•	•	•			
	Error Record Check	/	•	•	•			
	Parameter Inquiry	/	•	•	•			
	Reset	/	•	•	•			
User Account Management	Detailed Indoor Unit Parameter Display	/	•	•	•			
	User Information	/	/	/	•			
Control Type	User Account Management Level	/	/	/	•			
	Local Control Panel	•	•	•	/			
Communication	PC/App Version	/	/	/	•			
	Input	RS485	RS485	RS485	RS485			
	Output	RS485 Modbus	RS485 Modbus	/	Bacnet			

Item		Modbus Adaptor	BACnet Gateway
Model		40VCBM18FGLY	40VCBB18FGLY
Dimension (WxHxD) (mm)		280x120x60	130x109x35
Picture			
Power Supply		220V-AC	12V-DC
Connectivity	Max. Controllable Indoor Units	64	64
	Max. Outdoor Unit System (Max. Gateway#)	No limit	No limit
Display	Room Air/ Set Temperature	•	•
	General Indoor Unit status display	•	•
Standard Control Function	On/Off	•	•
	Mode (Auto-Cool-Dry-Heat-Fan)	•	•
	Temperature Setting	•	•
	Temperature Control	+/-1°C	+/-1°C
	Fan Speed (Auto-Low-Mid-High)	•	•
Advanced Function	Indoor Unit No. Display	•	•
	Indoor Unit Parameter Display	•	•
	Operation mode (Cooling only/Heat only/No limit)	•	/
Installer Info.	Error Code	•	•
	Detailed Indoor Unit Parameter Display	•	•
Communication	Input	RS-485	RS-485
	Output	RS-485 Modbus	Bacnet

Controller Line-up



Individual Controller



40VCI518FGLY
40VCIR18FGLY (Optional receiver)
Wireless Remote Controller

- Mode: Auto, cooling, dehumidification, fan mode, heating.
- Fan speed setting: Auto, low/medium/high speed.
- Temperature setting range: 16~32°C.
- Switch °F/°C.
- ECO function (26°C).
- Child lock function.
- Sleep function.
- Indoor units address setting.



40VCWT18FGLY
Touch Key Wired Controller

- Mode: Auto, cooling, dehumidification, fan mode, heating.
- Fan speed: Auto, low/medium/high speed.
- Temperature setting range: 16~32°C.
- Timer function.
- Set indoor unit address.
- Display error code.
- Switch °F/°C.
- ECO function (26°C).
- Sleep Function.
- Filter cleaning sign.
- More functions available on Carrier GCS App via built-in WiFi.



40VCW618FGLY
Simple Wired Controller

- Mode: Auto, cooling, dehumidification, fan mode, heating.
- Fan speed: Auto, low/medium/high speed.
- Temperature setting range: 16~32°C.
- 0.5°C temperature adjustment accuracy.
- Three/five core communication.
- Filter cleaning reminder.
- Switch °F/°C.
- Child lock function.
- Indoor unit address setting.
- Display error code.
- More functions available on Carrier GCS App via built-in WiFi.



40VCW518FGLY
Touch Screen Wired Controller

- Mode: Auto, cooling, dehumidification, fan mode, heating.
- Fan speed: Auto, low/medium/high speed.
- Temperature setting range: 16~32°C.
- Weekly timer function.
- Switch °F/°C.
- Set indoor unit address.
- ECO function (26°C).
- Display error code.
- Display time and date.
- Backlight, adjustable screen brightness.
- More functions available on Carrier GCS App via built-in WiFi.



Central Controller



40VCC418FGLY
Simple Central Controller

- Connect 100 indoor units.
- On/off, mode, temperature, fan speed, swing setting.
- Temperature setting range: 16~32°C.
- Individual or group control.
- Error code display, indoor unit operation data checking.
- Timing setting.
- Operation mode lock.
- One button for all on/off.
- MODBUS output.
- Available for top-discharge and side-discharge outdoor unit.



40VCCW38FGLY
C-Box

- On/off, mode, temperature, fan speed, swing setting.
- Individual control, or group control.
- Connect up to 100 Indoor units for top-discharge system, or 64 Indoor units for side-discharge system.
- Weekly schedule function.
- Display Time, Date and Day.
- OTA Central controller.
- More functions available on Carrier GCS App via built-in WiFi.

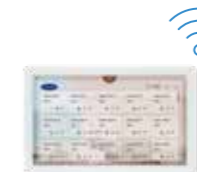

40VCC718FGLY
Touch Screen
Central Controller

- Connect 100 indoor units.
- On/off, mode, temperature, fan speed, swing setting.
- Error code display, indoor unit operation data checking.
- Weekly schedule function.
- MODBUS output.
- Display power meter readings.
- Switch °F/°C.
- OTA upgrade firmware.
- Display time and day.
- More functions available on Carrier GCS App via built-in WiFi.

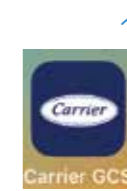

Carrier GCS APP
(Smart phone and Tablet)



- Compatible with Android and IOS system.
- Capable of multiple C-box connection through 1 App.
- Provide basic control for Indoor unit similar to central controller.
- Customisable user interface including language, temperature unit.
- Configure four intelligent control scenarios for air conditioners to optimize comfort and efficiency: Tap to activate all units instantly, automate operations to weather changes, schedule operations by time, or trigger specific units based on the status of other units within the system.
- Readily available through built-in WiFi in individual wired controller, touch screen central controller and C-Box.

Controller Line-up

Wi-Fi App Smart Scenario

Scenario-based control represents a significant advancement in air conditioning technology, offering users unparalleled flexibility in managing HVAC operations. By leveraging IoT integration, the system intelligently adapts to real-time weather conditions and air quality data sourced from the internet. This dynamic approach elevates operational performance, ensuring comfort, reliability, and energy efficiency.

Smart scenario

- Up to 100 scenarios
- Up to 10 conditions for each scenario
- Up to 150 actions possible for each scenario

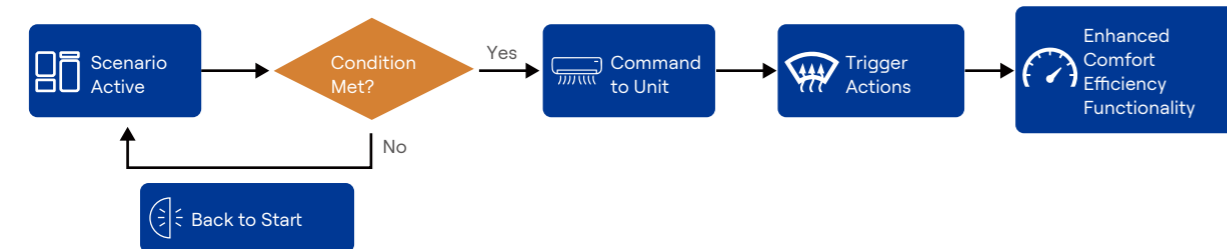
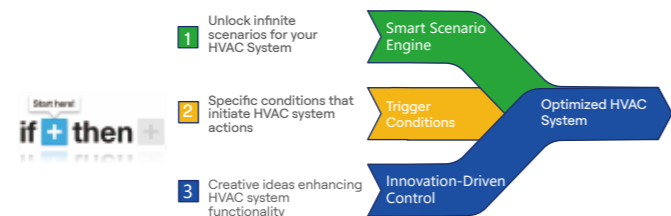

- Tap-to-Run: One click, multiple devices, different commands—simultaneously.
- Adaptive Operation: Automatically adjust the operation settings based on temperature, humidity, air quality, or PM2.5 levels
- Schedule Function: Customise settings for different days of the week to achieve indoor comfort at reduced energy consumption.
- Interlocking: Enable inter-device automation by triggering predefined actions when a device changes state—such as alarm activation or power-off events.

Central Control Wiring Diagram

Each VRF system can be connected to one central controller, and up to 100 indoor units can be connected in one system.

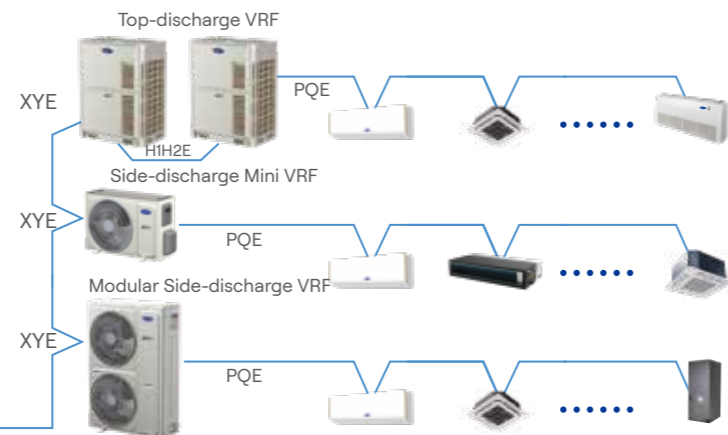

Controller Line-up

Network Central Controller



40VCC518FGLY-128/256/512/1024

- Connect up to 1024 indoor units, or maximum 120 systems.
- Applicable to top-discharge and side-discharge XCT8 series*.
- User interface via browser on PC windows system.
- Electricity billing management for top-discharge XCT8 series.
- Display of error code and indoor unit operation data .
- Weekly schedule function.
- Data logging for operation, run time and alarm record which can be exported, well suited for commercial or hotel building management.
- BACnet output.

*: Not applicable to modular side-discharge XCT8 series

Network Central Controller Wiring Diagram

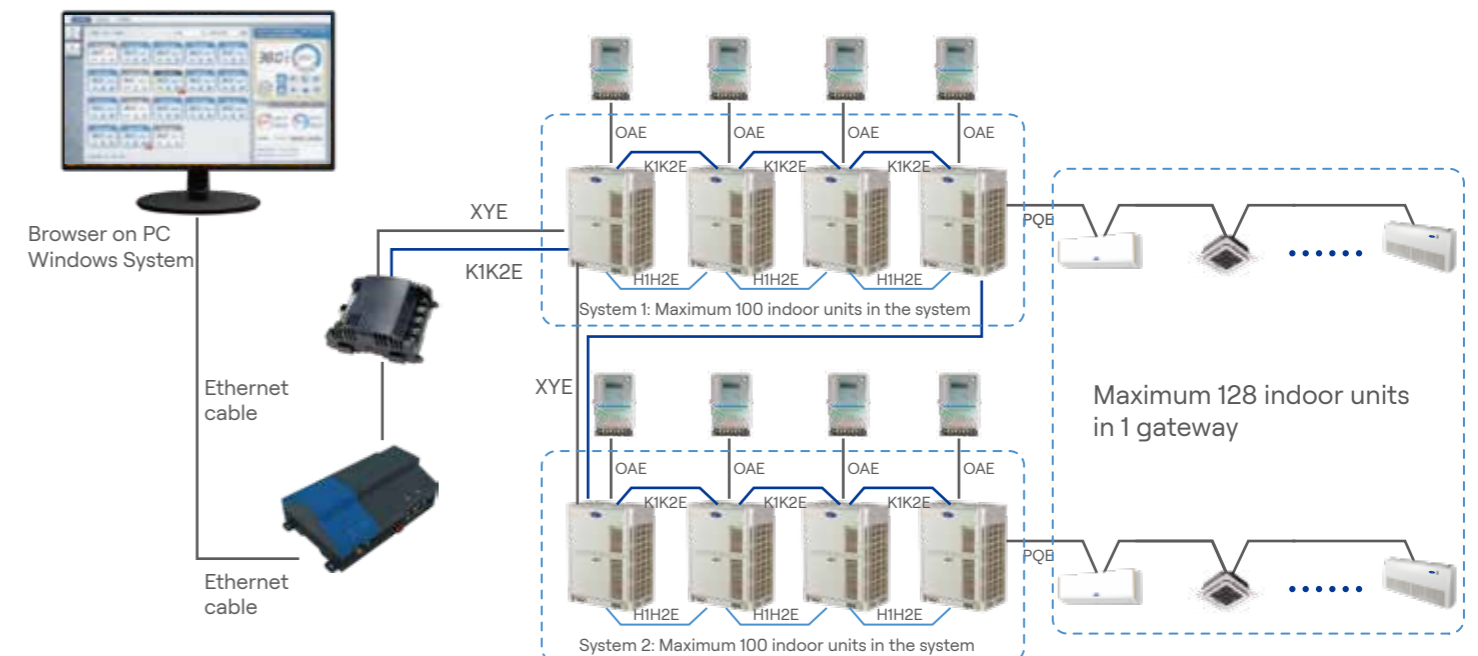

Controller Line-up

BMS Control-Modbus Adaptor



Modbus
40VCBM18FGLY

- Connect up to 64 indoor units (no limit on the number of system).
- Display of indoor status, parameters, operation mode.
- Error code display.
- On/Off control.
- Operation mode control.
- Temperature setting.
- Precise temperature control at 1°C.
- Fan speed control.
- Force cooling/heating/No restriction.
- Installation data including detail indoor unit parameters display.
- Communication input – RS485 / Output RS485 Modbus.

Built-in Modbus - Wiring Diagram

- Without Modbus adaptor - maximum 16 Systems, each system maximum 100 indoor units (Maximum 14 systems for side-discharge outdoor unit, 64 indoor units per system)
- Central control & monitoring via PC windows system.

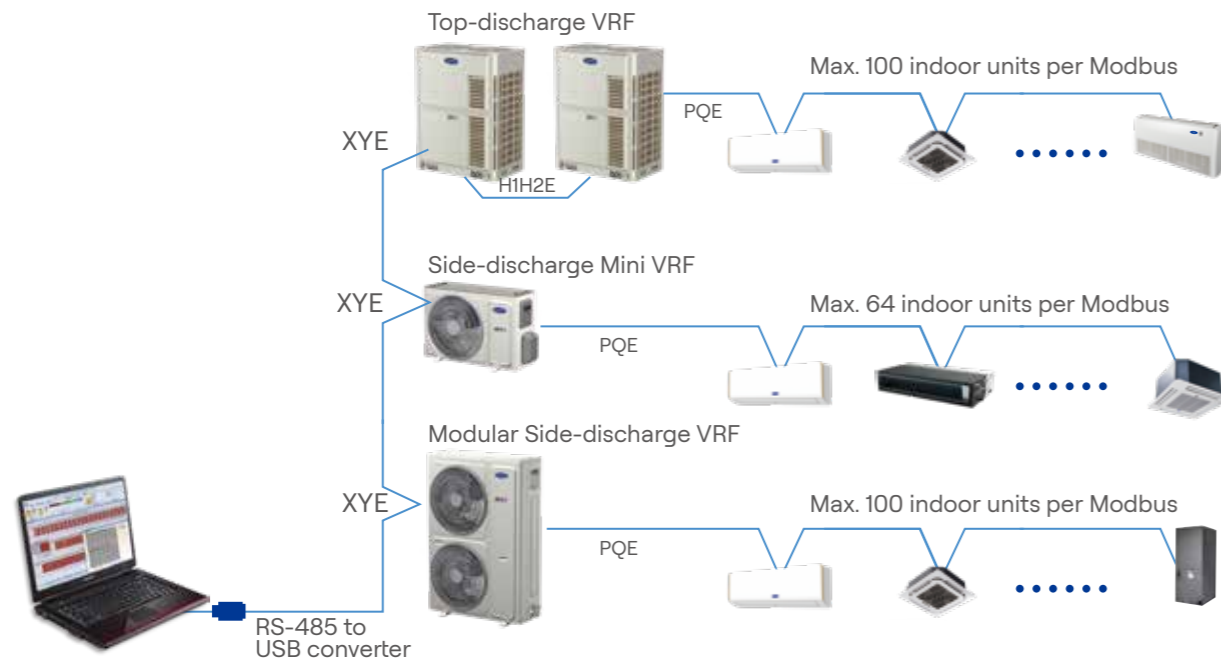

Controller Line-up

BMS Control-BACnet Gateway



BACnet Gateway
40VCBB18FGLY

- Connect up to 64 indoor units (no limit on the number of system).
- Display of indoor status, parameters, operation mode.
- Error code display.
- On/Off control.
- Operation mode control.
- Temperature setting.
- Precise temperature control at 1°C.
- Fan speed control.
- Installation data including detail indoor unit parameters display.
- Communication input – RS485 / Output BACnet.
- To be used in conjunction with Modbus adaptor (40VCBM18FGLY).

BACnet - Wiring Diagram

- A BACnet gateway has to be connected with Modbus adaptor; one BACnet gateway connects up to 64 indoor units.
- BACnet is connected to PC via ethernet cable, the number of BACnet gateway can be increased with multi-port ethernet router.

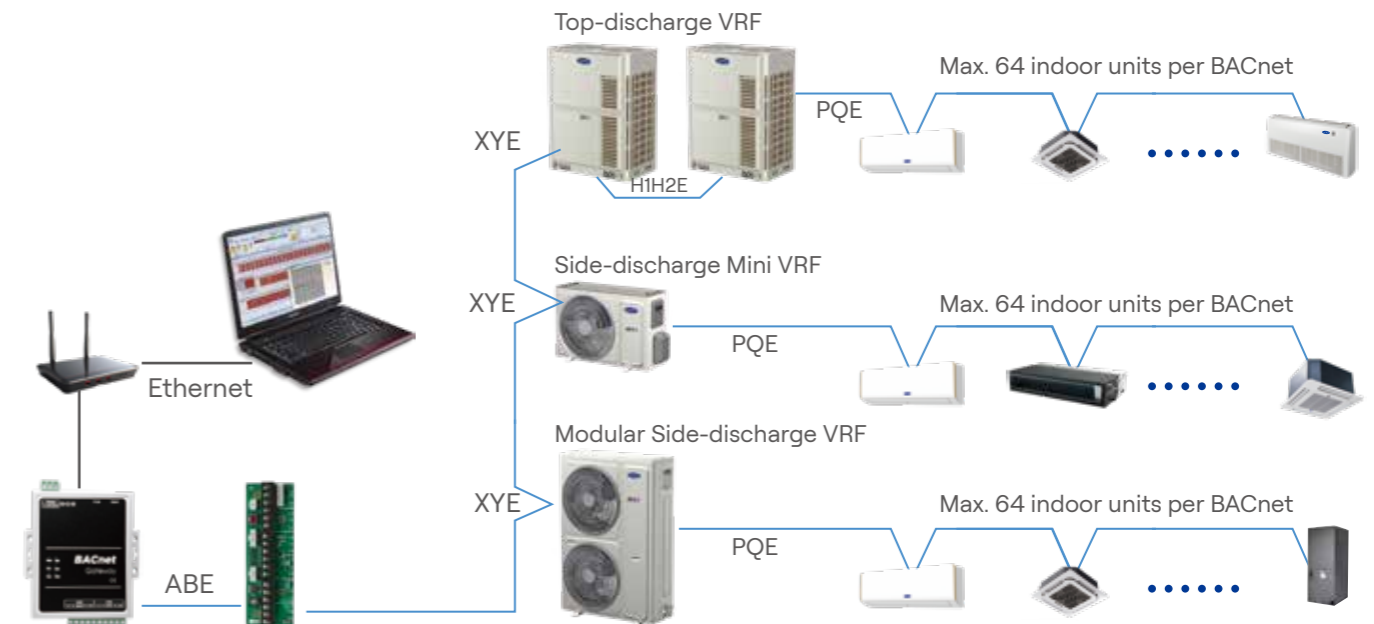

Controller Line-up

Outlook	Series				
	High Wall	●	○	○	○
	1-Way Cassette	●	○	○	○
	2-Way Cassette	●	○	○	○
	Compact Cassette	●	○	○	○
	Round Cassette	●	○	○	○
	Floor-Ceiling	●	○	○	○
	Low Static Duct	○	○	○	○
	Medium Static Duct	○	○	○	○
	High Static Duct	○	○	○	○
	Free Static Duct	○	○	○	○
	Vertical Duct	○	○	○	○
	Fresh Air Processor	○	○	○	○

● Standard ○ Option

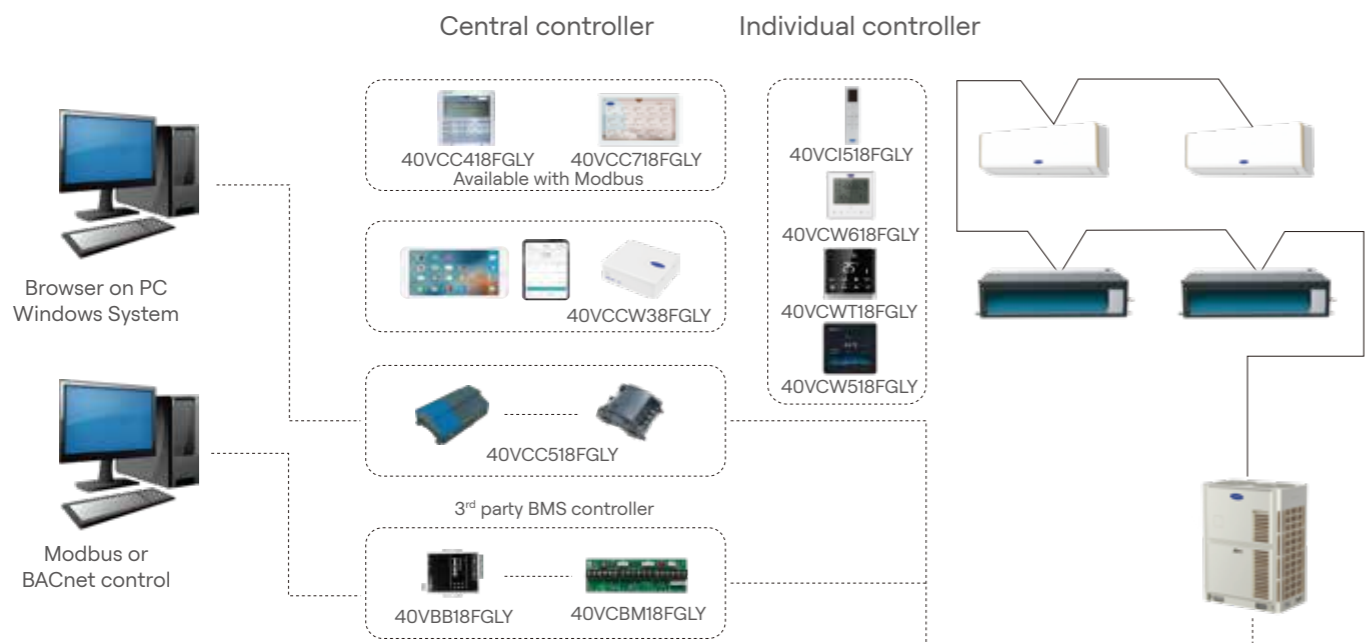

Accessories



Content ▶

- Accessories 114
 - AHU Kit
 - Pipe Connection Accessories

Accessories

AHU Kit*

- Interface kit to connect DX AHU to Carrier XCT8 VRF outdoor units.
- Each DX Coil Controller has an address and connects up to 4 DX Valve kit.
- Each AHU kit connects up to 120HP.

AHU Kit

DX Coil Controller	DX Valve Kit	Sensors & wires	Controller
<ul style="list-style-type: none"> • PCB • Power terminals • Communication terminals 	<ul style="list-style-type: none"> • Outlet pipe • Inlet pipe • EXV 	<ul style="list-style-type: none"> • T1 sensor and wire • T2 sensor and wire • T2B sensor and wire • Controller wire 	<ul style="list-style-type: none"> 40VCW618FGLY 40VCWT18FGLY 40VCW518FGLY

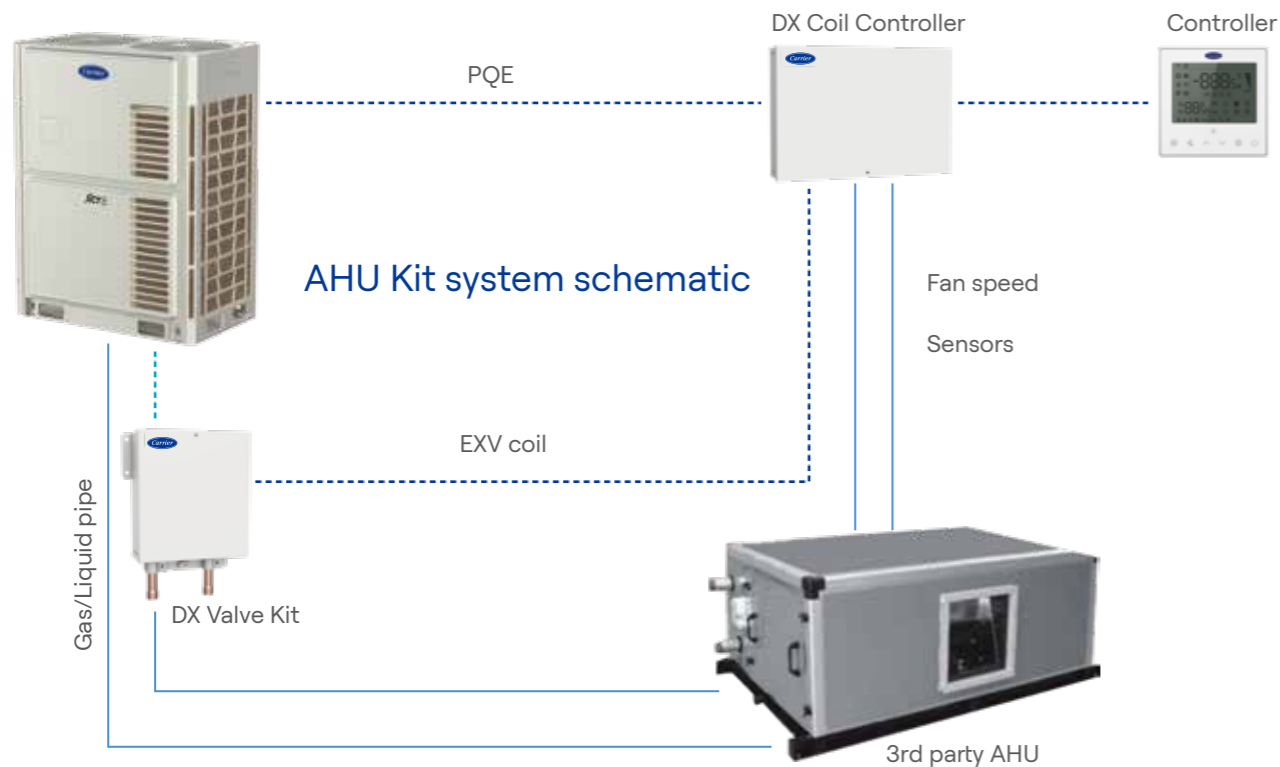

*: Connectable with XCT8 top-discharge and side-discharge outdoor unit. Modular side-discharge outdoor unit excluded.

Accessories

SW5 dial code 00 state 0: represents downward dialing to the digital end 1: represents upward dialing to the ON end				SW5 dial code 01 state 0: represents downward dialing to the digital end 1: represents upward dialing to the ON end				SW5 dial code 10 state 0: represents downward dialing to the digital end 1: represents upward dialing to the ON end			
SW1	Model	HP	DX Valve kit model and quantity	SW1	Model	HP	DX Valve kit model and quantity	SW1	Model	HP	DX Valve kit model and quantity
0	2.2kW	0.8HP	40VA003D8FAGLY 1 pcs	0	28kW	10HP	40VA014D8FAGLY 1 pcs	0	126kW	45HP	40VA022D8FAGLY 2 pcs
1	2.8kW	1HP		1	33.5kW	12HP		1	140kW	50HP	
2	3.6kW	1.2HP		2	40kW	14HP		2	154kW	55HP	
3	4.5kW	1.7HP	40VA003D8FAGLY 1 pcs	3	45kW	16HP	40VA022D8FAGLY 1 pcs	3	168kW	60HP	40VA022D8FAGLY 3 pcs
4	5.6kW	2HP		4	50kW	18HP		4	182kW	65HP	
5	7.1kW	2.5HP		5	56kW	20HP		5	196kW	70HP	
6	8.0kW	3HP	40VA007D8FAGLY 1 pcs	6	61.5kW	22HP	40VA014D8FAGLY 2 pcs	6	210kW	75HP	40VA022D8FAGLY 4 pcs
7	9.0kW	3.2HP		7	67kW	24HP		7	224kW	80HP	
8	11.2kW	4HP		8	73kW	26HP		8	238kW	85HP	
9	14kW	5HP	40VA014D8FAGLY 1 pcs	9	78.5kW	28HP	40VA022D8FAGLY 2 pcs	9	252kW	90HP	40VA022D8FAGLY 4 pcs
A	16kW	6HP		A	85kW	30HP		A	266kW	95HP	
B	20kW	7HP		B	90kW	32HP		B	280kW	100HP	
C	22.4kW	8HP	40VA014D8FAGLY 1 pcs	C	95kW	34HP	40VA022D8FAGLY 2 pcs	C	294kW	105HP	40VA022D8FAGLY 4 pcs
D	25.2kW	9HP		D	101kW	36HP		D	308kW	110HP	
E	25.2kW	9HP		E	106kW	38HP		E	322kW	115HP	
F	25.2kW	9HP		F	112kW	40HP		F	336kW	120HP	

Accessories Piping Dimension

Accessories

Shape	Model	Description
Piping accessory of outdoor unit connection for Maximum 3 module combinations		
	40VJ064G8-HGLY	For two units combination
	40VJ096G8-HGLY	For three units combination
Piping accessory of outdoor unit connection for Maximum 4 module combinations		
	40VJ040G8-CGLY	For two units combination
	40VJ060G8-CGLY	For three units combination
	40VJ080G8-CGLY	For four units combination
Piping accessory of indoor unit connection		
	40VJ008M8-HGLY	≤22kW
	40VJ010M8-HGLY	22kW~28kW
	40VJ037M8-HGLY	28kW~104kW
	40VJ055M8-HGLY	104kW~154kW
	40VJ088M8-HGLY	154kW~ 245kW
	40VJ096M8-HGLY	245kW~ 269kW
	40VJ0124M8-HGLY	≥269kW
	40VAD006P8FGLY	External drain pump

Outdoor Unit Piping Dimension

Capacity of outdoor unit (HP)	Equivalent length of all pipes <90m		Equivalent length of all pipes > 90m	
	Gas (mm)	Liquid (mm)	Gas (mm)	Liquid (mm)
8	Φ19.05	Φ9.52	Φ22.2	Φ12.7
10	Φ22.2	Φ9.52	Φ25.4	Φ12.7
12/14	Φ25.4	Φ12.7	Φ28.6	Φ15.88
16	Φ28.6	Φ12.7	Φ31.8	Φ15.88
18~24	Φ28.6	Φ15.88	Φ31.8	Φ19.05
26~34	Φ31.8	Φ19.05	Φ38.1	Φ22.2
36~54	Φ38.1	Φ19.05	Φ41.2	Φ22.2
56~66	Φ41.2	Φ19.05	Φ44.5	Φ22.2
68~82	Φ44.5	Φ22.2	Φ54.0	Φ25.4
84~96	Φ50.8	Φ25.4	Φ54.0	Φ28.6

Indoor Unit Piping Dimension

Connected indoor unit capacity (kW)	Gas (mm)	Liquid (mm)	Branch pipe model
A<6.5	Φ12.7	Φ9.52	40VJ008M8-HGLY
6.5≤A<18	Φ15.88	Φ9.52	
18≤A<22	Φ19.05	Φ9.52	
22≤A<28	Φ22.2	Φ9.52	40VJ010M8-HGLY
28≤A<47	Φ28.6	Φ12.7	40VJ037M8-HGLY
47≤A<71	Φ28.6	Φ15.88	
71≤A<104	Φ31.8	Φ19.05	
104≤A<154	Φ38.1	Φ19.05	40VJ055M8-HGLY
154≤A<180	Φ41.2	Φ19.05	40VJ088M8-HGLY
180≤A<245	Φ44.5	Φ22.2	
245≤A<269	Φ54.0	Φ25.4	40VJ096M8-HGLY
269≤A	Φ54.0	Φ28.6	40VJ124M8-HGLY