



40LBU/38LHU Series
Direct Expansion Fan Coil Unit
60,000-150,000 BTU/H



40LBU Series

Specification

Model Name	Outdoor Unit		38LHU060S301	38LHU078S301	38LHU100S301	38LHU120S301	38LHU150S301
	Indoor Unit		40LBU006X	40LBU008X	40LBU010X	40LBU012X	40LBU015X
Total Cooling Capacity		kW	17.6	22.9	29.3	35.2	44.0
		Btu/hr.	60,000	78,000	100,000	120,000	150,000
Power Supply		V/Ph/Hz	380-415Volt / 3Phase / 50Hz. (4wires)				
Air Flow Rate	Rate	CFM	2,100	2,600	3,500	4,000	5,100
	Min-Max	CFM	1800-2100	2300-2600	3200-3500	3500-4000	4500-5100
CONDENSING UNIT							
Power Supply		V/Ph/Hz	380/3/50				
Power Consumption		W	5,590	6,680	8,810	11,130	13,380
Operating Current		Amp.	11.07	13.40	18.55	21.81	8.31
Compressor	Power Supply	V/Ph/Hz	380/3/50				
	Compressor Type		Scroll				
	QTY		1	1	1	1	1
Fan Motor	Power Supply	V/Ph/Hz	220/1/50	380/3/50			
	Power Input	W	264	336	336	630	630
	RLA	Amp.	1.27	1	1	2.01	2.01
	Fan Type		Propeller				
	Drive Type		Direct				
	QTY		1	1	1	1	1
Safety Device	Hi-Pressure Switch	psig	600 +25 / 420 +15 (Cut out / Cut in) - Auto Restart type				
	Low-Pressure Switch	psig	65 +5 / 115 +5 (Cut out / Cut in) - Auto Restart type				
Refrigerant	Type		R-410A				
	Pre-Charging from Factory	kg.	4.2	0.6	0.6	1.3	2.0
Piping Connections	Liquid	inch	3/8 (Flare)	1/2 (Flare)			5/8 (Flare)
	Suction	inch	7/8 (Flare)		1 1/8 (Brazing)		
Dimension	Height	mm.	690	845	1050	1150	
	Width	mm.	800	900	1040	1050	
	Depth	mm.	725	915	1192	1294	
Net weight		kg.	98	128	151	200	210
FAN COIL UNIT							
Power Supply		V/Ph/Hz	380/3/50				
Cooling Coil	Coil Arrangement	Row/FPI	3R/14 FPI	3R/14 FPI	3R/14 FPI	3R/14 FPI	3R/14 FPI
	Coil Face Area	Sq.Ft	4.44	5.31	7.15	8.00	10.22
	Tube / Fin Material Type		COPPER/ALUMINIUM				
	No. of Circuit		1	1	1	1	1
Fan	Type		CENTRIFUGAL FORWARD CURVED BLADE				
	Size	inch	10"x10"	10"x10"	12"x12"	10"x10"	12"x12"
	QTY		1	1	1	2	2
	Std. Revolution Speed	rpm	720	810	720	789	715
Motor	Power Supply	V/Ph/Hz	380/3/50				
	Type		TEFC - Totally Enclosed Fan Cooled				
	Power	HP	3/4 (4P)	1 (4P)	2 (4P)	2 (4P)	3 (4P)
	Q'ty		1	1	1	1	1
	Revolution Speed	rpm	1,450	1,450	1,450	1,450	1,450
Accessories	Fan Pulley		180-1A-25	160-1A-25	180-1A-25	225-1B-25	250-1B-20
	Motor Pulley		90-1A-14	90-1A-19	90-1A-24	125-1B-24	125-1B-28
	Belt		A-33	A-32	A-34	B-49	B-54
	Belt Q'ty		1	1	1	1	1
Air Filter	Type		Washable Aluminium Air Filter				
	Q'ty Size (Width x Height x Thickness)	inch	2..460x480x1"	2..460x565x1"	3..452x525x1"	2..16"x25"x1" 2..10"x25"x1"	4..16"x25"x1"
Insulation	Type		PE.Foam				
	Thermal Conductivity		0.036 w/m.K				
	Thickness	mm.	10 MM.				
Connecting Pipe	Liquid Q'ty	inch	3/8"	1/2"	1/2"	5/8"	2..5/8"
	Suction Q'ty	inch	7/8"	7/8"	1-1/8"	1-1/8"	2..7/8"
	Drain O.D. (FPT)	inch	3/4" MPT	3/4" MPT	3/4" MPT	3/4" MPT	3/4" MPT
Dimension	Height	mm.	600	600	650	770	770
	Width	mm.	1225	1400	1630	1490	1830
	Depth	mm.	870	870	935	1000	1000
Net weight		kg.	109	114	139	209	269

Remark : RLA : Rated Load Amps

MPT : Male Pipe Tread

*Nominal Capacity based on : Entering Air Temp. 80°F Db / 67°F Wb , At maximum air flow rate

Unit dimensions

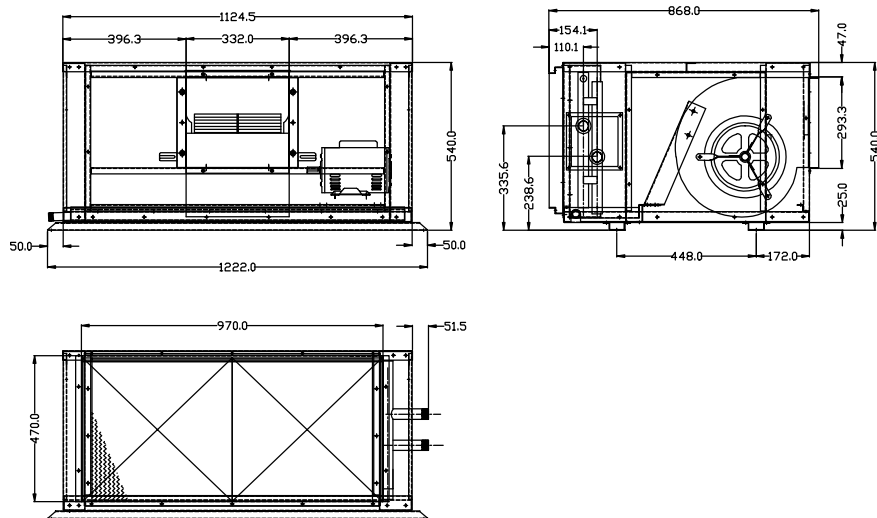

Model: 40LBU006

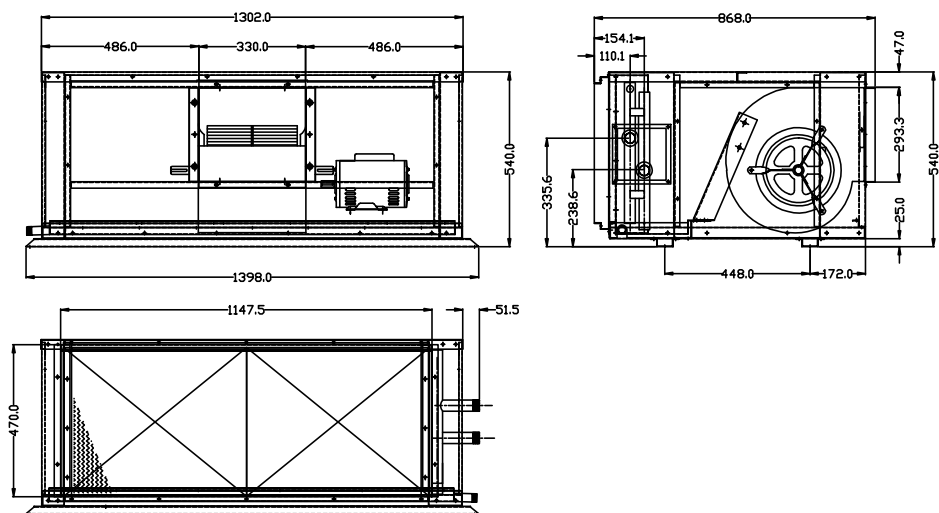

Model: 40LBU008

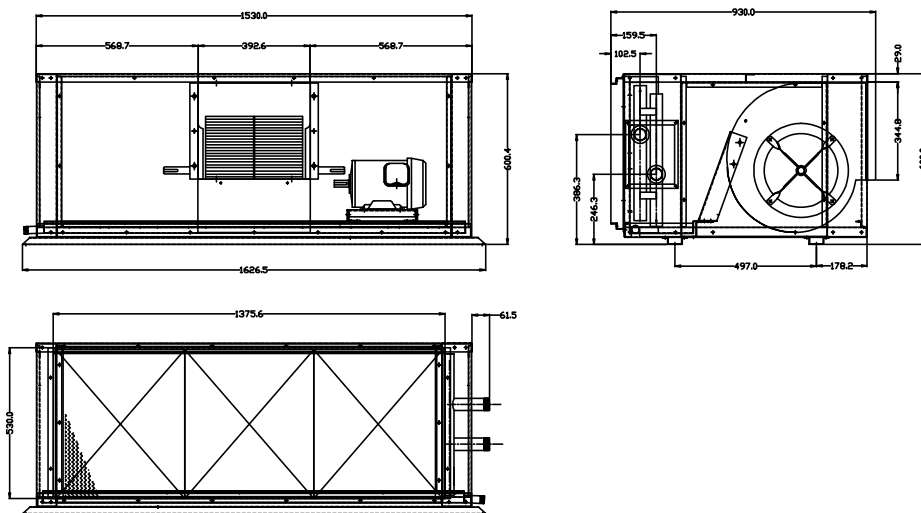

Model: 40LBU010

Unit dimensions

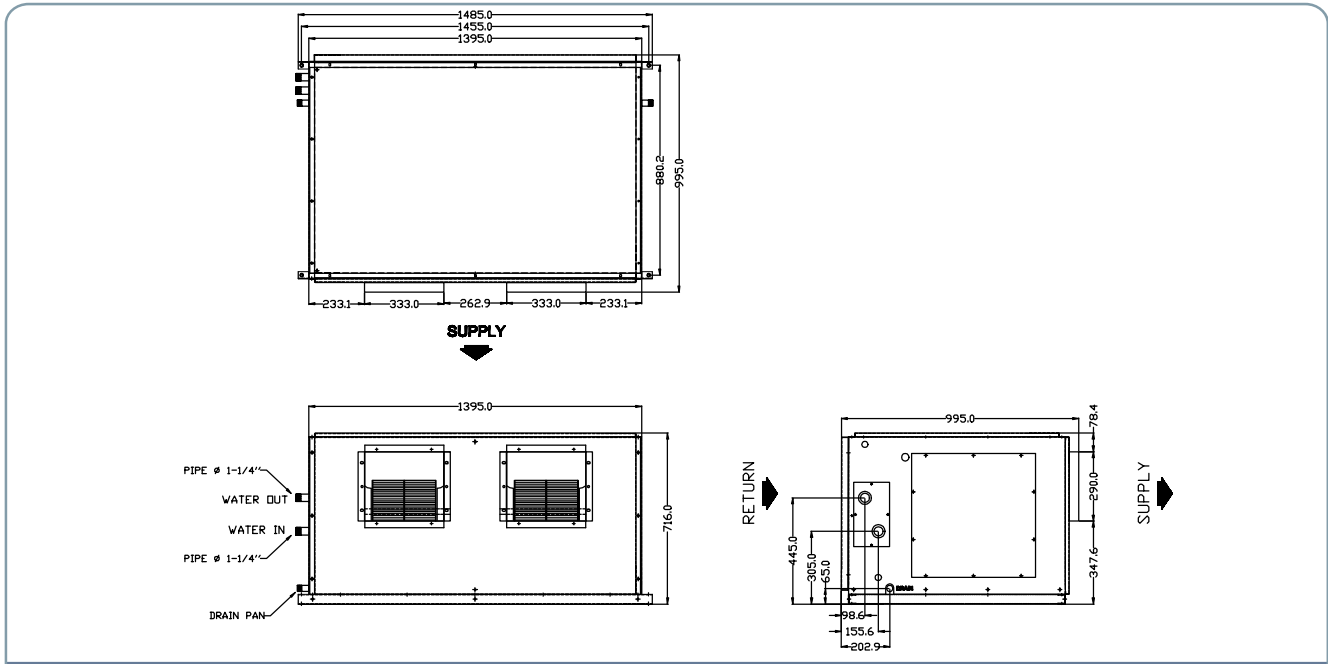

Model: 40LBU012

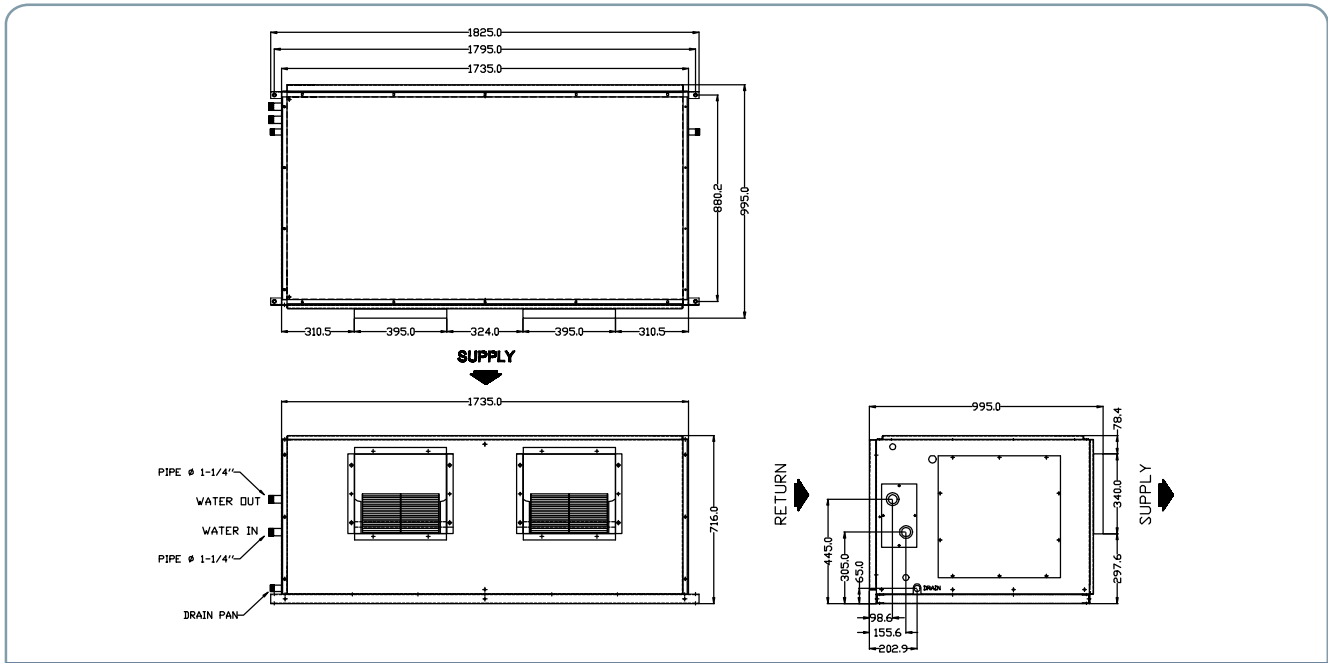

Model: 40LBU015



◀ 38LHU Series

บริษัท แคนเรียร์ (ประเทศไทย) จำกัด
1858/63-74 ชั้น 14, 15
ถ.เทพรัตน กม. 4.5 แขวงบางนาใต้
เขตบางนา กรุงเทพฯ 10260
โทร. 0-2090-9999 แฟกซ์: 0-2751-4778

Carrier (Thailand) Ltd.
1858/63-74, 14th, 15th Floor,
Debaratna Road, Km.4.5, Bangna Tai,
Bangna Bangkok 10260 Thailand
Tel. 0-2090-9999 Fax: 0-2751-4778



Website
Commercial HVAC Thailand



Facebook
Carrier HVAC Thailand



MUOIOS



Warranty
Carrier HVAC Thailand

บริษัทฯ ขอสงวนสิทธิ์ที่จะเปลี่ยนแปลงรายละเอียดข้างต้น โดยไม่ต้องแจ้งให้ทราบล่วงหน้า
Carrier reserves the right to make changes in specifications without prior notice.