



United Technologies

turn to the experts



AQUASNAP[®]

30RB/RQ Modular Air-Cooled Liquid Chiller Reversible Air-to-Water Heat Pump

Nominal cooling capacity: 65kW

Nominal heating capacity: 68kW



Turn To The Experts

Inheriting a rich legacy of innovation including inventing modern air-conditioning, Carrier has been a global leader in innovations for Heating Ventilation Air Conditioning (HVAC) and refrigeration solutions. Carrier is a part of UTC Climate, Controls & Security, a unit of United Technologies Corp., a leading provider to the aerospace and building systems industries worldwide.

With a broad portfolio of advanced technical patent awards, our global R&D center in Shanghai develops innovative heat, ventilation and air-conditioning (HVAC) solutions.



In 1998, Time magazine named Dr. Carrier one of its 20 most influential builders and titans of the 20th century.



Nomenclature

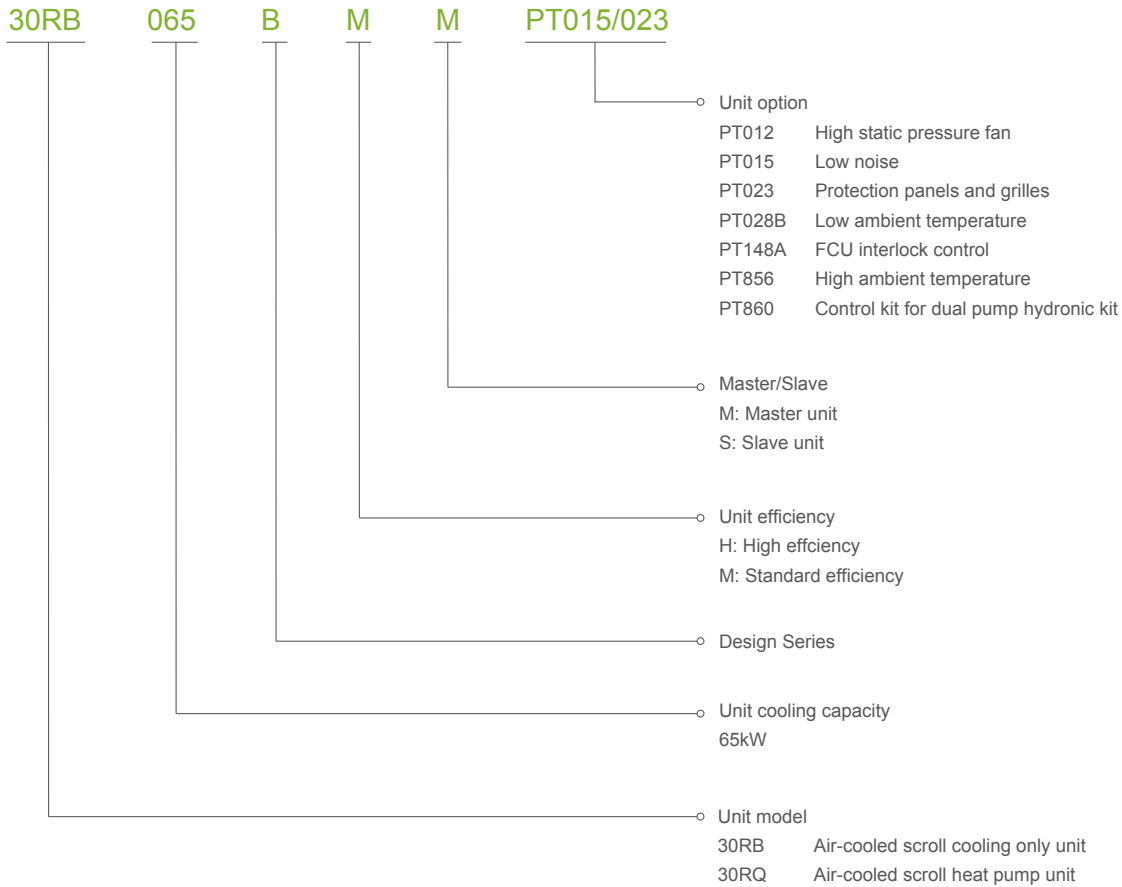

Note:

1. System controller will be shipped inside of master unit's control box.
2. If select PT028B, it is mandatory to apply brine for anti-freezing.
3. Employ entering water temperature control as default for single and multiple modular connection.
4. PT859B is mandatory for modular chiller when external VFD pump hydronic kit is ordered.
5. PT860 is mandatory for modular chiller when external dual pump hydronic kit is ordered.

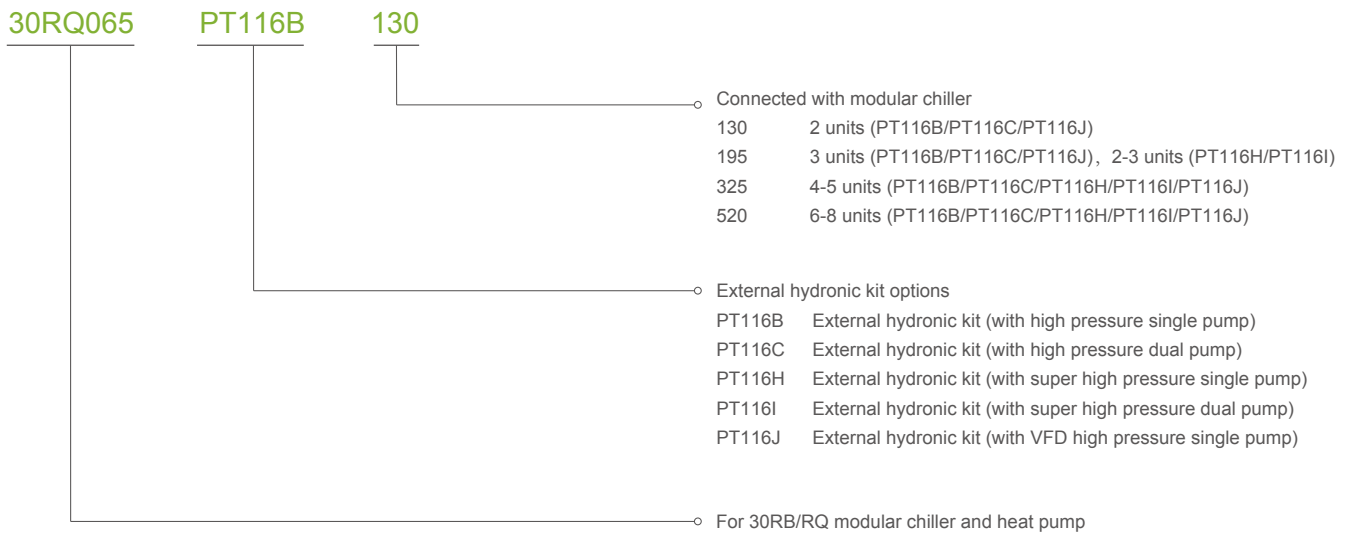

* Unit shown on cover is with PT023 protection panels and grilles option

Operating Range, 30RB

Cooling mode

Evaporator	Minimum	Maximum
Entering water temperature at start-up	12 C	30 C
Leaving water temperature during operation	4 C	20 C
Entering/leaving water temperature difference	-	9K
Condenser	Minimum	Maximum
Outdoor air temperature*	0 C	43 C

* Maximum outside temperature: For transport and storage of the 30RB/RQ units the minimum and maximum allowable temperatures are -20 C and +50 C. It is recommended that these temperatures are used for transport by container.

30RB065 cooling mode*

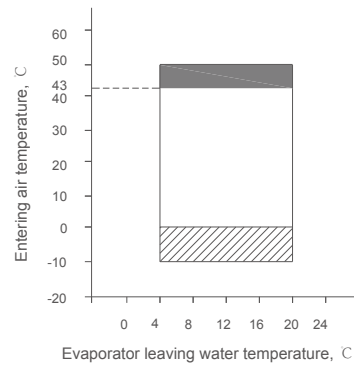

- Operation range, unit equipped with PT856 high ambient temperature operation
- Operating range, stand and unit
- Operation range, unit equipped with PT028B low temperature ambient operation. In addition the water loop must use glycol to protect BPHE from frozen risk when unit start up or shut down

* The envelope is based on the full load

Operating Range, 30RQ

Cooling mode

Water heat exchanger (Evaporator)	Minimum	Maximum
Entering water temperature at start-up	12 C	30 C
Leaving water temperature during operation	4 C	20 C
Entering/leaving water temperature difference	-	9K
Air heat exchanger (Condenser)	Minimum	Maximum
Outdoor air temperature*	0 C	43 C

* Maximum outside temperature: For transport and storage of the 30RB/RQ units the minimum and maximum allowable temperatures are -20 C and +50 C. It is recommended that these temperatures are used for transport by container.

Heating mode

Water heat exchanger (Condenser)	Minimum	Maximum
Entering water temperature at start-up	3.3 C	45 C
Leaving water temperature during operation	30 C	55 C
Entering/leaving water temperature difference	-	9K
Air heat exchanger (Evaporator)	Minimum	Maximum
Outdoor air temperature	-10 C	25 C

30RQ065 cooling mode*

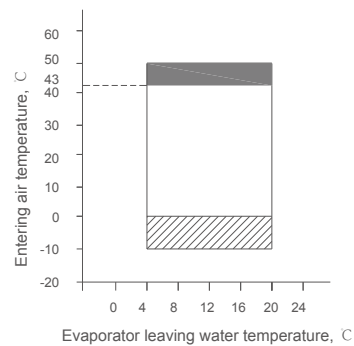

- Operation range, unit equipped with PT856 high ambient temperature operation
- Operating range, stand and unit
- Operation range, unit equipped with PT028B low temperature ambient operation. In addition the water loop must use glycol to protect BPHE from frozen risk when unit start up or shut down

* The envelope is based on the full load

30RQ065 heating mode

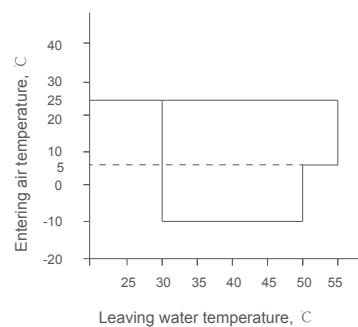

Features

- ✔ The new generation of Aquasnap modular chillers/heat pumps is the new design type catering for flexible combination to suit different capacity needs and installation space. It is the premium solution for commercial and light commercial applications such as the air conditioning of office, hotel, complex building and industry, etc.

Benefits

- ✔ Environment sound refrigerant HFC-410A of zero ozone depletion potential.
- ✔ Extremely high full load and system part load energy efficiency leads to low operation cost.
- ✔ Flexible combination of modular design type meets various capacity requirement and system capacity extension needs.
- ✔ Low operating sound with no intrusive low-frequency noise creates a better working/living environment.
- ✔ Multiple modules and robust control system ensure superior reliability to minimize chiller down-time.

Environmental sound

- ✔ Ozone-friendly HFC-410A refrigerant
 - Chlorine-free refrigerant of the HFC group with zero ozone depletion potential.
 - High-density refrigerant, therefore less refrigerant required.
 - Very efficient - gives an increased energy efficiency ratio.
- ✔ Leak-tight refrigerant circuit
 - Brazed refrigerant connections for increased leaktightness.
 - Reduction of leaks due to reduced vibration levels and elimination of capillary tubes.
 - Verification of pressure transducers and temperature sensors without transferring refrigerant charge.

Economical operation

- ✔ Extremely high full load efficiency and system part load efficiency
 - High tier offering boosts full load cooling efficiency above 3.2 and standard tier at 3.1.
 - The multiple module system offers flexible capacity control step to respond customer load change, its high system part load efficiency leads to more economical operating cost.
 - Counter flow brazed plate heat exchanger ensures high efficient heat transfer.
 - Electronic expansion device (EXV) allows operation at a lower condensing pressure. (EER and COP optimization) and improved utilization of the evaporator heat exchange surface(dynamic super heat control).
- ✔ Optimized defrost control algorithm reduced the defrost cycle (30RQ only)
- ✔ Reduced maintenance costs
 - Maintenance-free scroll compressors.
 - Fast diagnosis of possible incidents and their history via the Auto-adaptive Plus control.
 - HFC-410A refrigerant is easier to use than other refrigerant blends.

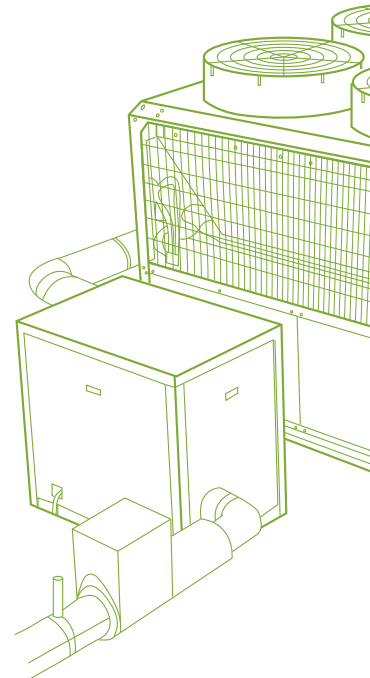

Flexible combination

- Max. 12 modules stack up in parallel in one control system extending cooling/heating capacity to 780/816kW.
- Cooling only and heat pump modular could flexibly stack up addressing diverse capacity needs by mix combined technology.
- Ease of system extension and multi-phase investment benefiting customer in capital utilization.

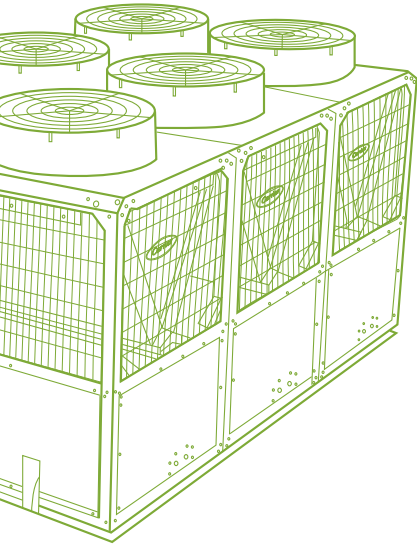

Quiet operation

- Compressors
 - Low-noise scroll compressors with low vibration level.
 - The compressor assembly is installed on an independent chassis and supported by anti-vibration mountings.
 - Dynamic suction and discharge piping support minimize vibration transmission (Carrier patent).
 - Acoustic compressor enclosure reduces radiated noise emission (option).
- Condenser section
 - Condenser coils in V-shape with an open angle allows quieter air flow across the coil.
 - Low-noise 4th generation Flying Bird fans (Carrier patent) enjoy quieter operation and never generate intrusive low-frequency noise.
 - Rigid fan mounting preventing start-up noise (Carrier patent).



Easy and fast installation

- Single module with compact footprint is easy for storage, shipping, lifting and installation.
- Multiple modulars connected in lateral with one side water piping ensure compact installation footprint, saving valuable space for customer.
- Extra screw/victaulic water connection adapts for various jobsite needs.
- Innovative external hydronic kit integrates all the necessary hydronic components, saving valuable installation time, effort and space.
 - Centrifugal high or super high pressure water pump provides diverse lifts for different applications.
 - Dual pumps apply operating time balancing and automatic changeover to the back-up pump if any fault occurs.
 - VFD pump kit reduces obviously the energy consumption based on load variation and the number of modular units operating.
 - High-capacity membrane expansion tank ensures pressurization of the water circuit.

Auto-adaptive Control

Auto-adaptive Control combines intelligence with operating simplicity. The control constantly monitors all machine parameters and precisely manages the operation of compressors, expansion devices, fans for optimum energy efficiency.

User-friendly interface

- ✔ The new backlit LCD ensures legibility, the information is in clear text and can be displayed in English.
- ✔ Unit uses intuitive tree-structure menus, similar to the Internet navigators. They are user-friendly and permit quick access to the principal operating parameters of master and each slave unit: operating mode, compressors operating status, suction pressure, compressor operating hours, set point, air temperature, entering and leaving water temperature.

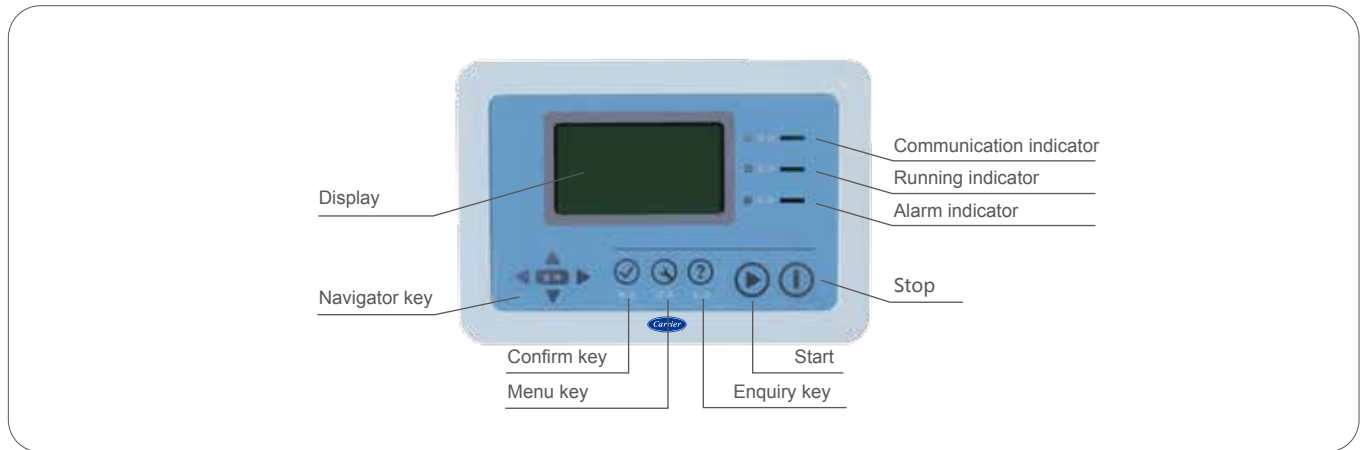

Advanced control function

- ✔ Unit control function including: Unit ON/OFF, user safety interlock, water pump control, operation indication, circuit alarm and alert etc.
- ✔ System can start/stop according to FCU status via FCU interlock controller (option).
- ✔ Intelligent defrost control algorithm reduced the defrost cycle duration and automatically balance the defrost sequence of more than one unit which have defrosting request at the same time (30RQ only).
- ✔ Password protection in case of mishandling.

Powerful diagnostics

- ✔ Real-time monitor all the control and operation parameters, alarm when necessary.
- ✔ As many as 12 diagnostics to protect unit : water flow detective, water temperature out of range protection, compressor reverse, low chilled water temperature, high/low refrigerant pressure, motor overload, anti-freeze protection, etc. The diagnostics histories are recorded and could be easily visited via system controller.

Group control

- ✔ Master/slave control of group modular operating in parallel with run time equalization and automatic changeover in case of fault.
- ✔ One system controller could support maximum 12 modules, which gives more flexibility for capacity extension.
- ✔ With RS485 port and Modbus protocol, remote control of multiple modular gets available through communication with Building Automation System (BAS).



Modular Unit Technical Specifications

Performance data

Model		30RB065BHM/S	30RB065BMM/S	30RQ065BHM/S	30RQ065BMM/S
Nominal cooling capacity*	kW	65	65	65	65
Compressor power input(cooling)	kW	18.1	18.9	18.3	19.7
EER	kW/kW	3.30	3.17	3.27	3.05
Nominal heating capacity*	kW	/	/	68	68
Compressor power input(heating)	kW	/	/	19.0	19.6
COP	kW/kW	/	/	3.30	3.21
Refrigerant		HFC-410A			
Circuit A	kg	8.0	5.5	8.0	6.7
Circuit B	kg	8.0	5.5	8.0	6.7
Compressor		Hermetic scroll compressors			
Circuit A		1	1	1	1
Circuit B		1	1	1	1
Number of capacity stages		2	2	2	2
Minimum capacity	%	50	50	50	50
Condensers		Grooved copper tubes and aluminium fins			
Fans		Axial Flying Bird IV with rotating shroud			
Quantity		2	2	2	2
Total air flow	l/s	6834	6834	6834	6834
Speed	rpm	700	700	700	700
Water heat exchanger		Brazed plate heat exchanger			
Water volume	l	5.06	5.06	5.94	5.06
Nominal water flow rate, cooling mode	l/s	3.1	3.1	3.1	3.1
Nominal water flow rate, heating mode	l/s	/	/	3.3	3.3
Unit internal water pressure drop, cooling mode***	kPa	67	67	60	67
Unit internal water pressure drop, heating mode***	kPa	/	/	66	75
Max. water-side operating pressure	kPa	1600	1600	1600	1600
Water connections		Victaulic			
Nominal diameter		DN50	DN50	DN50	DN50
Electrical data					
Main power supply		400V-3Ph-50Hz (three-phase five line)			
Control power supply		230V (unit built in)			
Nominal unit operating current draw, circuit A/B	A	33.1	34.4	33.4	35.7
Maximum operating current draw, circuit A/B	A	45.0	43.0	45.0	43.0
Maximum start-up current, circuit A/B	A	176.0	176.0	176.0	176.0
Total fan power input	kW	1.6	1.6	1.6	1.6
Unit length	mm	2236	2236	2236	2236
Unit width	mm	1100	1100	1100	1100
Unit height	mm	1898	1898	1898	1898
Shipping weight**	kg	574	538	610	576
Operation weight	kg	580	543	616	581

* Nominal cooling mode - evaporator entering/leaving water temperature 12/7 °C, outside air temperature 35 °C
 Nominal heating mode - water heat exchange entering/leaving water temperature 40/45 °C, outside air temperature 7 °C/6 °C;
 Water heat exchanger fouling factor - 0.018m²/kW.

**Unit only, not include additional shipping package weight 20kg.

***Unit internal pressure drop includes BPHE, Y strainer and water pipes.

Options & accessories

Options	No.	Description	Advantages	Use
High static pressure fan	012	950RPM to provide 120Pa static pressure for indoor unit installation with discharge ducts	Ducted condenser air discharge, optimized condensing temperature control	30RB065BHM/S 30RB065BMM/S 30RQ065BHM/S 30RQ065BMM/S
Low noise	015	Acoustic compressor enclosure	Noise emission reduction by 2dBA	
Protection panels and grilles	023	Metallic panels and grilles on all four unit faces	Better chiller protection and aesthetics	
Low ambient temperature	028B	Fan running No. controlled by condensing pressure	Stable operation with air temperature down to -10C	
FCU interlock control	148A	Fan-coil interlock controller	Provide interlock function between FCU and master modular	
High ambient temperature	856	Optimized designed control box adaptive to high ambient temperature	Stable unit operation with air temperature up to 50C	
Control kit for VFD pump hydronic kit	859B	Control kit for for matched with VFD pump hydronic kit	-	
Control kit for dual pump hydronic kit	860	Control kit matched with dual pump hydronic kit	Optimized and adaptive performance	

Multiple Modules Performance Data

Cooling capacity (kW)	65	130	195	260	325	390	455	520
Heating capacity (kW)	68	136	204	272	340	405	476	544
Modular No.	1	2	3	4	5	6	7	8
Piping DN recommendation	≥DN50	≥DN80	≥DN80	≥DN100	≥DN100	≥DN125	≥DN125	≥DN125

Hydronic Kit Technical Specification

Hydronic kit model	Modular Qty	Nominal water flow rate*	Pump water pressure*	Customer available water pressure** (with standard efficiency modular)		Customer available water pressure** (with high efficiency modular)		Expansion tank volume	Maximum water side pressure	Connection diameter	Pump power input	Pump maximum operating current draw	Main power supply	Recommended wiring size
				30RB	30RQ	30RB	30RQ							
	unit	m³/h	kPa	kPa		kPa		l	kPa	DN	kW	A		mm²
External hydronic kit (high pressure single pump)	High pressure single pump, control box, Y strainer, safety valve, expansion tank, pressure gauge, air vent valves, victaulic water connection, etc.													
30RQ065PT116B130	2	22.4	270	186	186	186	193	35	500	DN65	4.0	7.1	400V-3Ph-50hZ	1.0x2.5 (Min.) 1.0x10.0 (Max.)
30RQ065PT116B195	3	33.6	282	198	198	198	205	50	500	DN80	5.5	9.8		
30RQ065PT116B325	4	44.8	260	176	176	176	183	80	500	DN100	7.5	13.7		
	5	56.0	245	161	161	161	168							
30RQ065PT116B520	6	67.2	288	204	204	204	211	80	500	DN100	11.0	19.6		
	7	78.4	276	192	192	192	199							
	8	89.6	255	171	171	171	178							
External hydronic kit (high pressure dual pump)	High pressure dual pump, control box, Y strainer, safety valve, expansion tank, pressure gauge, air vent valves, victaulic water connection, etc..													
30RQ065PT116C130	2	22.4	250	166	166	166	173	35	500	DN65	4.0	7.1	400V-3Ph-50hZ	1.0x2.5 (Min.) 1.0x10.0 (Max.)
30RQ065PT116C195	3	33.6	270	186	186	186	193	50	500	DN80	5.5	9.8		
30RQ065PT116C325	4	44.8	250	166	166	166	173	80	500	DN100	7.5	13.7		
	5	56.0	235	151	151	151	158							
30RQ065PT116C520	6	67.2	273	189	189	189	196	80	500	DN100	11.0	19.6		
	7	78.4	258	174	174	174	181							
	8	89.6	230	146	146	146	153							

* at nominal cooling condition

** at nominal cooling condition, customer available pressure = pump water pressure - modular chiller water pressure loss,

Need to consider the water head loss of the piping between external hydronic kit and modular chiller

*** at 50Hz

Hydronic kit model	Modular Qty	Nominal water flow rate*	Pump water pressure*	Customer available water pressure** (with standard efficiency modular)		Customer available water pressure** (with high efficiency modular)		Expansion tank volume	Maximum water side pressure	Connection diameter	Pump power input	Pump maximum operating current draw	Main power supply	Recommended wiring size				
				30RB	30RQ	30RB	30RQ											
	unit	m³/h	kPa	kPa		kPa		l	kPa	DN	kW	A		mm²				
External hydronic kit (super high pressure single pump)		Super high pressure single pump, control box, Y strainer, safety valve, expansion tank, pressure gauge, air vent valves, victaulic water connection, etc.																
30RQ065PT116H195	2	22.4	335	251	251	251	258	50	500	DN65	5.5	9.8	400V-3Ph-50hZ	1.0x2.5 (Min.) 1.0x10.0 (Max.)				
	3	33.6	305	221	221	221	228											
30RQ065PT116H325	4	44.8	320	236	236	236	243	80	500	DN100	7.5	13.7			400V-3Ph-50hZ	1.0x2.5 (Min.) 1.0x10.0 (Max.)		
	5	56.0	300	216	216	216	223											
30RQ065PT116H520	6	67.2	328	244	244	244	251	80	500	DN100	15.0	27.4					400V-3Ph-50hZ	1.0x2.5 (Min.) 1.0x10.0 (Max.)
	7	78.4	318	234	234	234	241											
	8	89.6	306	222	222	222	229											
External hydronic kit*** (super high pressure dual pump)		Super high pressure dual pump, control box, Y strainer, safety valve, expansion tank, pressure gauge, air vent valves, victaulic water connection, etc.																
30RQ065PT116I195	2	22.4	315	231	231	231	238	50	500	DN65	5.5	9.8	400V-3Ph-50hZ	1.0x2.5 (Min.) 1.0x10.0 (Max.)				
	3	33.6	293	209	209	209	216											
30/RQ065PT116I325	4	44.8	310	226	226	226	233	80	500	DN100	7.5	13.7			400V-3Ph-50hZ	1.0x2.5 (Min.) 1.0x10.0 (Max.)		
	5	56.0	290	206	206	206	213											
30RQ065PT116I520	6	67.2	313	229	229	229	236	80	500	DN100	15.0	27.4					400V-3Ph-50hZ	1.0x2.5 (Min.) 1.0x10.0 (Max.)
	7	78.4	300	216	216	216	223											
	8	89.6	281	197	197	197	204											
External hydronic kit*** (VFD high pressure single pump)		VFD high pressure single pump, control box, Y strainer, safety valve, expansion tank, pressure gauge, air vent valves, frequency converter, electronic bypass valve, pressure sensor, victaulic water connection, etc.																
30RQ065PT116J130	2	22.4	284	200	200	200	207	35	500	DN65	4.0	7.1	400V-3Ph-50hZ	1.0x2.5 (Min.) 1.0x10.0 (Max.)				
30RQ065PT116J195	3	33.6	290	206	206	206	213	50	500	DN80	5.5	9.8						
30RQ065PT116J325	4	44.8	272	188	188	188	195	80	500	DN100	7.5	13.7			400V-3Ph-50hZ	1.0x2.5 (Min.) 1.0x10.0 (Max.)		
	5	56.0	250	166	166	166	173											
30RQ065PT116J520	6	67.2	294	210	210	210	217	80	500	DN100	11.0	19.6					400V-3Ph-50hZ	1.0x2.5 (Min.) 1.0x10.0 (Max.)
	7	78.4	275	191	191	191	198											
	8	89.6	245	161	161	161	168											

Dimensions/Clearances

30RB/RQ

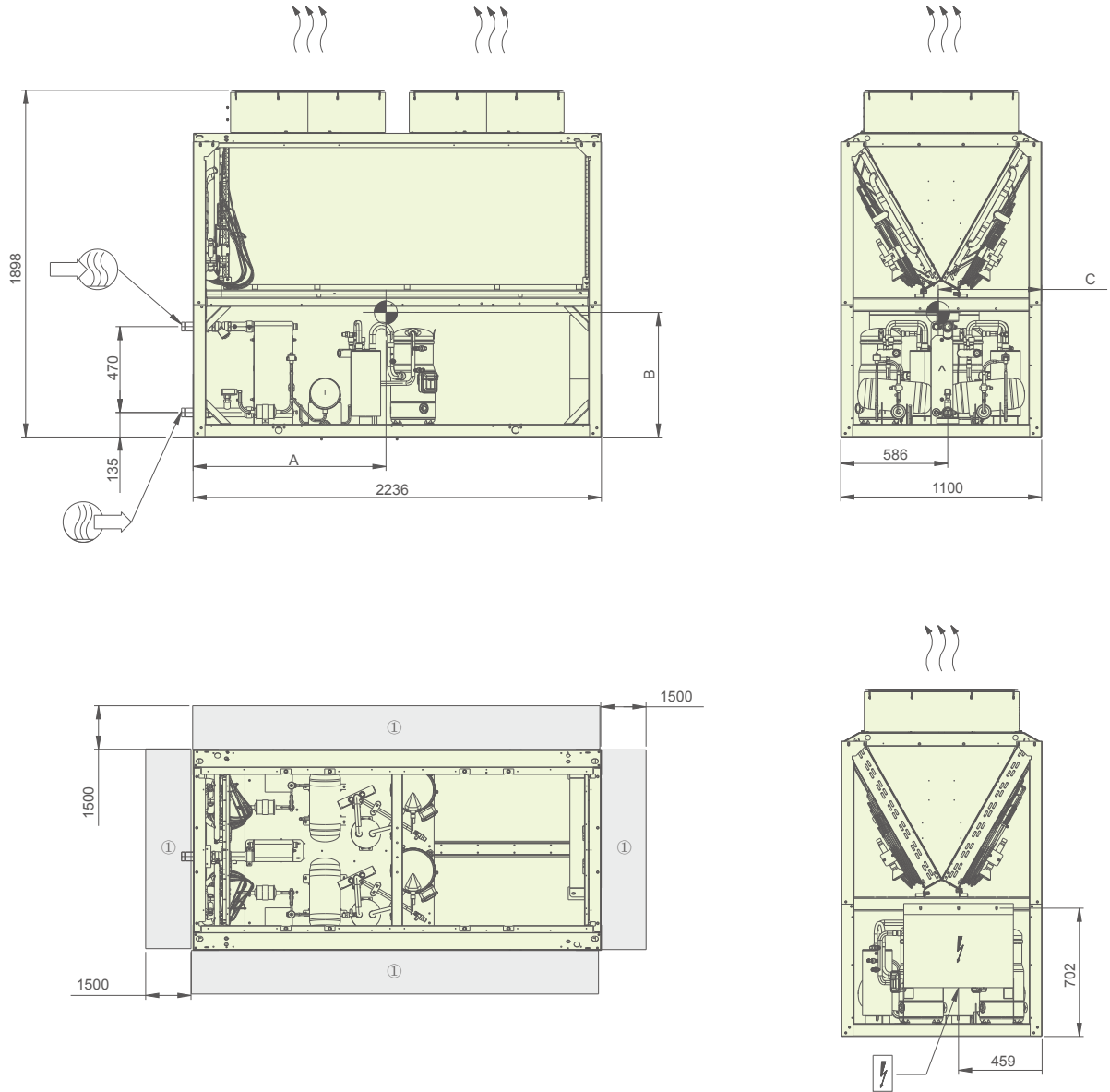

- ① Required clearances for air entry
- Water inlet
- Water outlet
- Air outlet - do not obstruct
- Power supply inlet
- Unit gravity center

Model	A	B	C
30RB065BHS/BMS	1044	737	594
30RQ065BHS/BMS	1056	682	566

Hydronic Kit Dimension

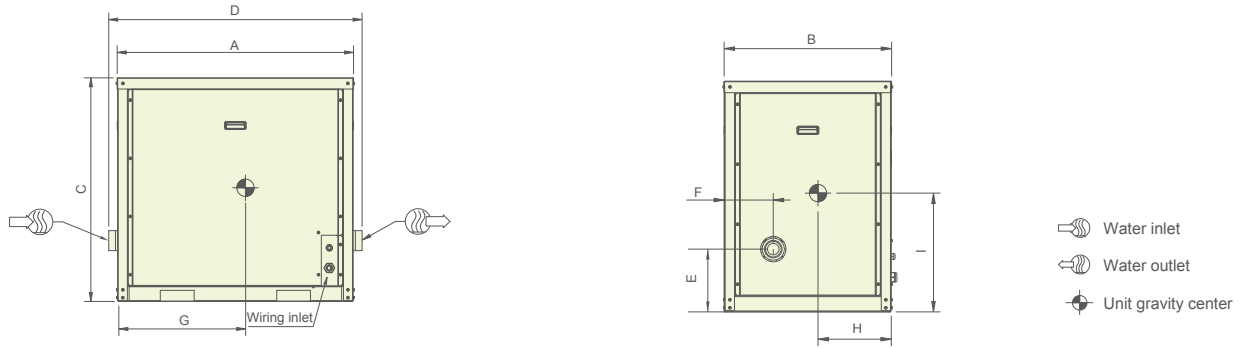

Model	A	B	C	D	E	F	G	H	I
30RQ065PT116B130	1056	726	1000	1132	272	212	572	438	487
30RQ065PT116B195							572	438	487
30RQ065PT116H195							574	435	491
30RQ065PT116B325	1641	916	1280	1746	430	252	901	552	620
30RQ065PT116H325						896	547	616	
30RQ065PT116B520						901	552	620	
30RQ065PT116H520						458	901	552	620

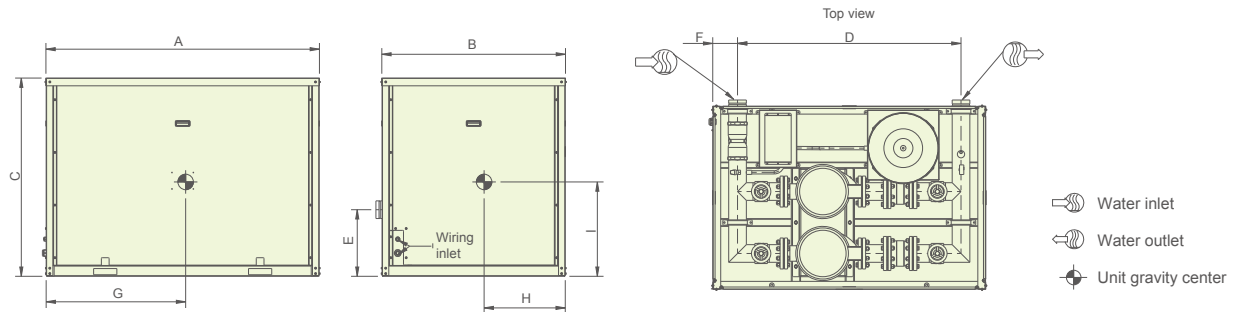

Model	A	B	C	D	E	F	G	H	I
30RQ065PT116C130	1366	986	1000	1100	272	133	623	420	438
30RQ065PT116C195							619	411	460
30RQ065PT116I195							619	411	460
30RQ065PT116C325	1766	1186	1280	1443	430	160	818	521	596
30RQ065PT116I325							818	521	596
30RQ065PT116C520							798	502	668
30RQ065PT116I520							798	502	668

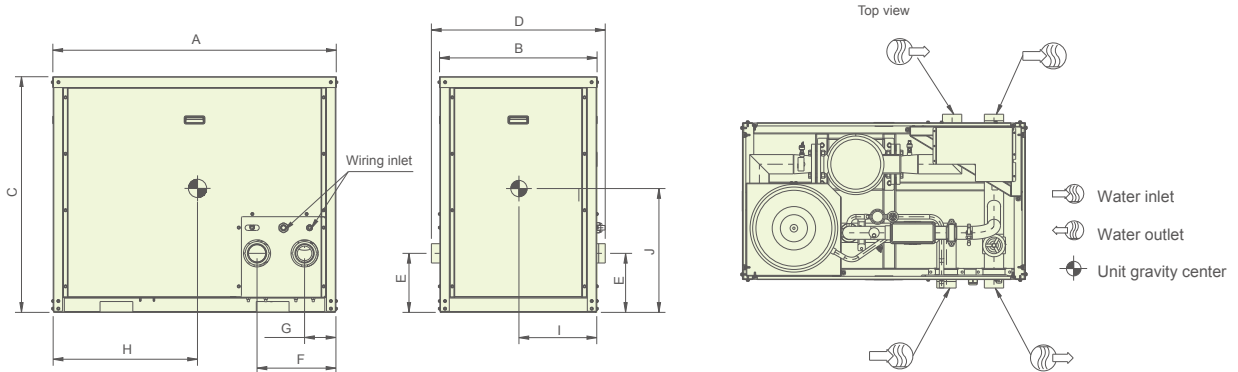

Model	A	B	C	D	E	F	G	H	I	J
30RQ065PT116J130	1306	728	1086	801	272	363	144	649	386	454
30RQ065PT116J195	1306	728	1086	801	272	363	144	649	409	479
30RQ065PT116J325	1468	913	1187	986	272	393	144	765	556	584
30RQ065PT116J520	1468	913	1187	986	272	393	144	765	556	584

Installation Basement and Weight Distribution

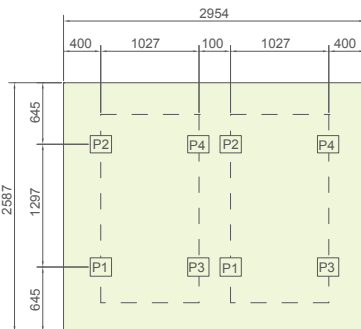
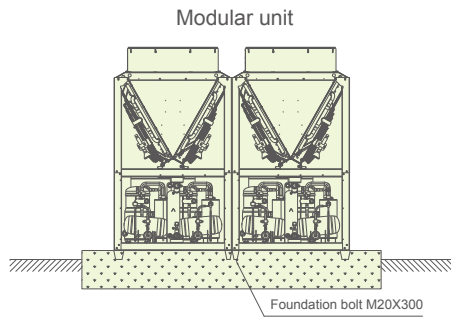

Model	Operating Weight (kg)	P1 (kg)	P2 (kg)	P3 (kg)	P4 (kg)
30RB065BHM/S	580	174	140	148	118
30RB065BMM/S	543	165	131	138	109
30RQ065BHM/S	616	167	150	158	141
30RQ065BMM/S	581	158	141	149	133

1. The installation basement shall be concrete structure or channel steel frame that is strong enough to support unit operating weight.
2. Each unit shall be fixed by four bolts(M20)
3. Anti-vibration pads (20mm) shall be installed between the unit chassis and basement.

External hydronic kit

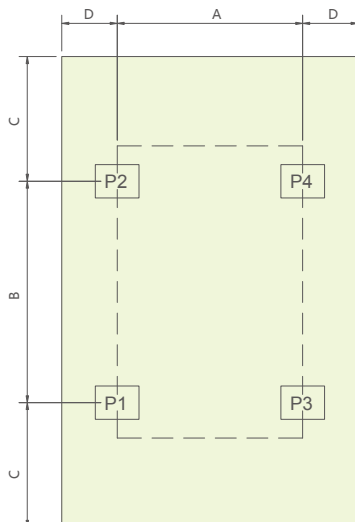
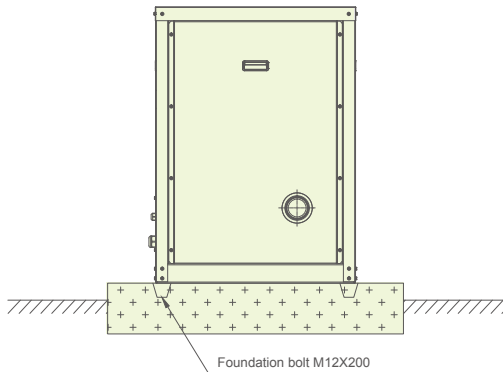

Model	Operating Weight (kg)	P1 (kg)	P2 (kg)	P3 (kg)	P4 (kg)	A (mm)	B (mm)	C (mm)	D (mm)
30RQ065PT116B130	215	75	36	57	47	670	640	350	150
30RQ065PT116B195	258	90	43	68	57	670	640	350	150
30RQ065PT116B325	368	128	62	97	82	860	1162	400	200
30RQ065PT116B520	546	190	92	143	121	860	1162	400	200
30RQ065PT116C130	386	97	127	92	71	930	900	400	200
30RQ065PT116C195	462	117	155	109	82	930	900	400	200
30RQ065PT116C325	641	158	204	158	121	1130	1000	500	200
30RQ065PT116C520	793	191	269	195	138	1130	1000	500	200
30RQ065PT116H195	248	86	42	64	56	670	640	350	150
30RQ065PT116H325	358	122	62	94	80	860	1162	400	200
30RQ065PT116H520	546	189	92	143	122	860	1162	400	200
30RQ065PT116I195	462	117	155	109	82	930	900	400	200
30RQ065PT116I325	641	158	204	158	121	1130	1000	500	200
30RQ065PT116I520	793	191	269	195	138	1130	1000	500	200
30RQ065PT116J130	215	75	36	57	47	1130	640	500	200
30RQ065PT116J195	258	90	43	68	57	1130	640	500	200
30RQ065PT116J325	368	128	62	97	82	1130	640	500	200
30RQ065PT116J520	546	190	92	143	121	1130	640	500	200

1. The installation basement shall be concrete structure or channel steel frame that is strong enough to support unit operating weight.
2. Each unit shall be fixed by four bolts(M12)
3. Anti-vibration pads (10mm) shall be installed between the unit chassis and basement.

Multiple Modules Installation

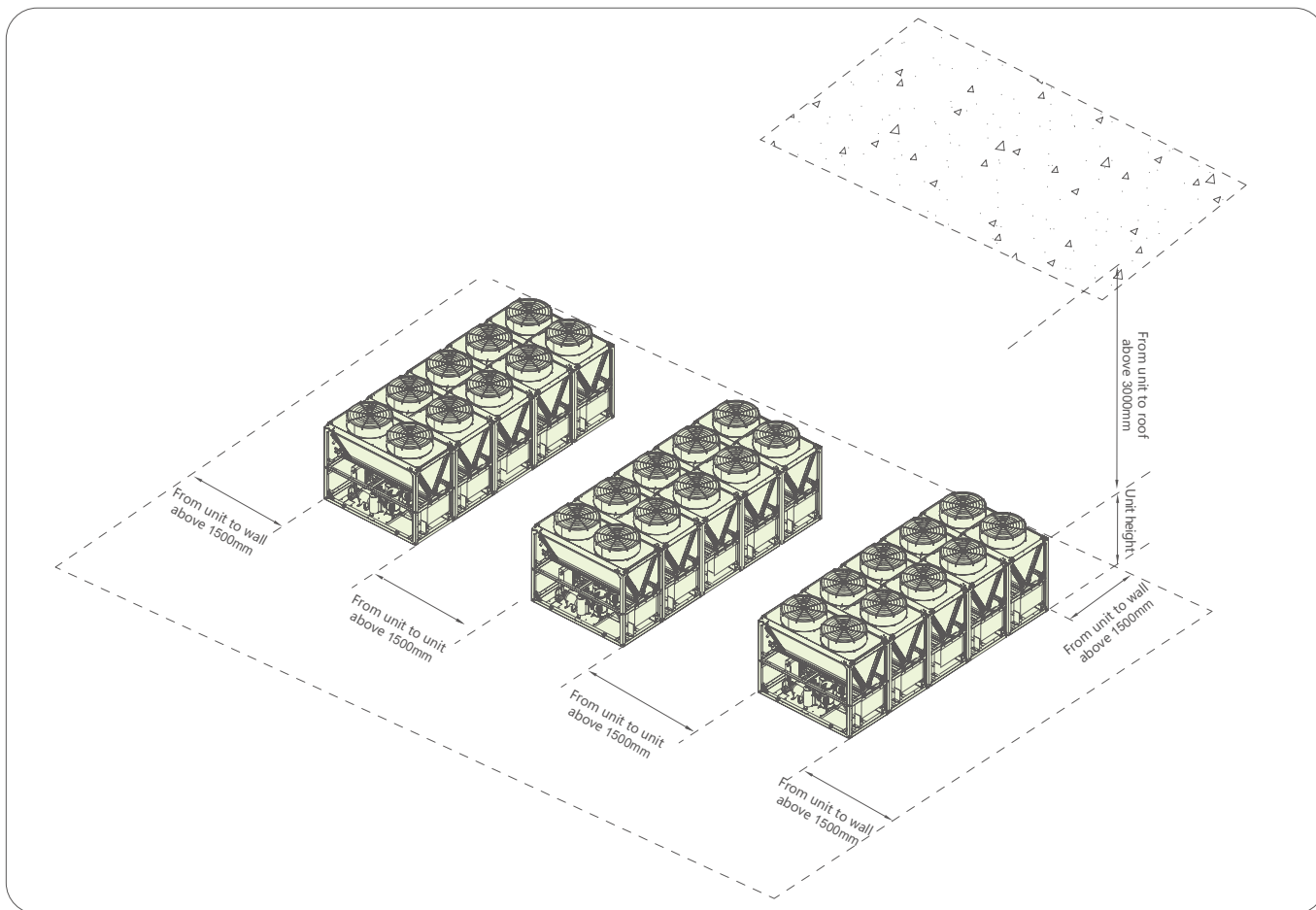

Service Space

External hydronic kit

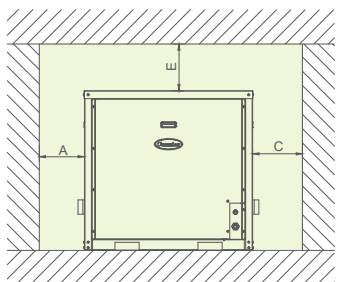
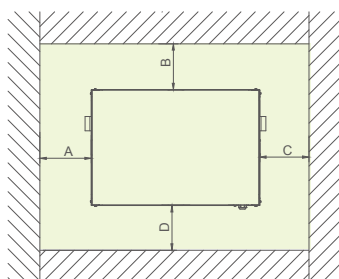

Recommended height difference

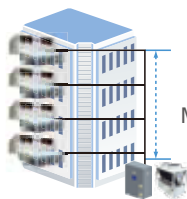

Max. 20m

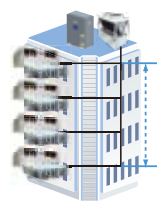

Max. 100m

Placed on ground

Placed on roof

Model	30RQ065PT116B 130/195/325/520 30RQ065PT116H 195/325/520	30RQ065PT116C 130/195/325/520 30RQ065PT116I 195/325/520	30RQ065PT116J 130/195/325/520
A (mm)	600	500	500
B (mm)	500	600	600
C (mm)	600	500	500
D (mm)	500	500	600
E (mm)	100	100	100

Typical Water Connection

External hydronic kit (fixed speed dual pump)

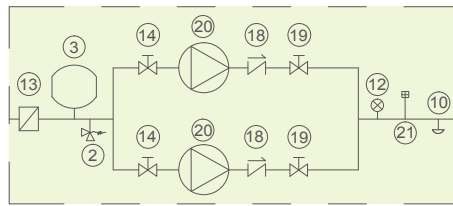

External hydronic kit (fixed speed single pump)

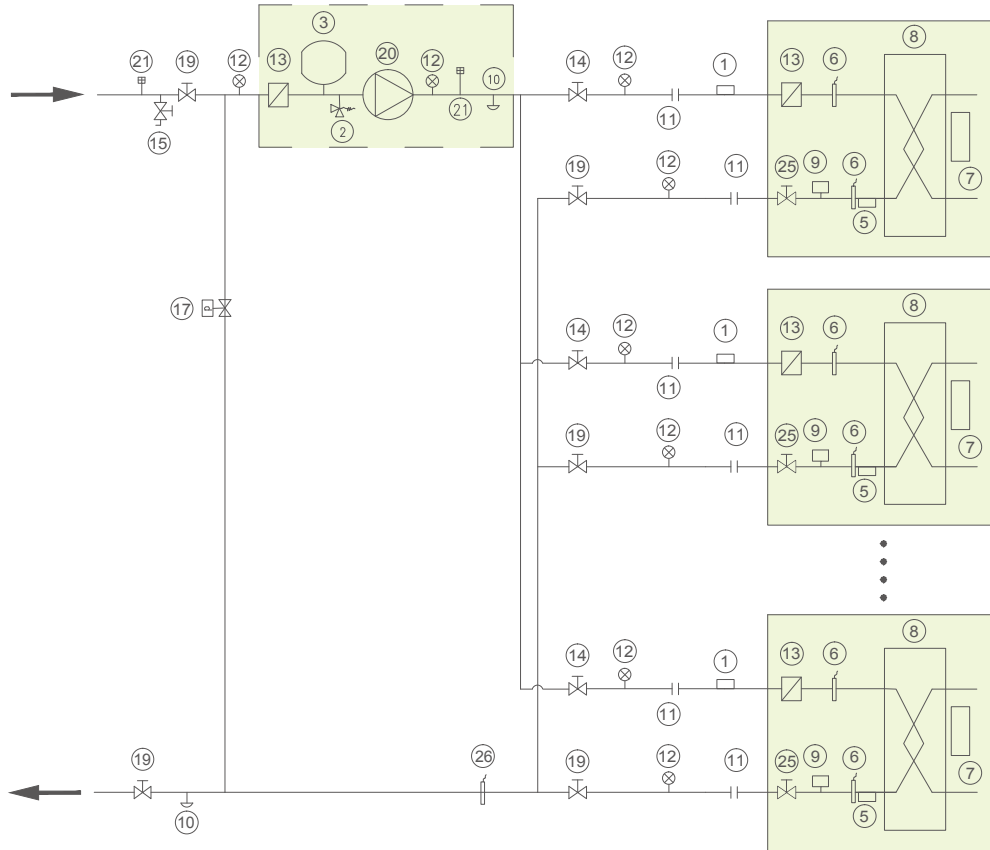

Unit components	Installation components	
	Included in kit	Not included in kit
5 Drain screw plug	2 Safety valve	1 Manual air vent
6 Temperature sensor	3 Expansion tank	11 Flexible connection
7 BPHE heater	10 Drain valve	14 Flow control valve**
8 Brazed plate exchanger	12 Pressur gauge	15 Charge valve
9 Flow switch*	13 Filter	17 Bypass valve
13 Filter	18 Check valve	19 Stop valve
25 Eletrical ball valve(PT859)****	19 Stop valve	21 Auto air vent
	20 Pump	
	21 Auto air vent ***	

Note: * 30RB/RQ065 Unit flow switch is installed at BPHE outlet;

** Recommend flow regulating valve as butterfly valve or sluice valve etc. instead of stop valves like ball valve;

***Air vent valves should be installed at the highest point of water loop. Drain valve must be installed at the lowest point of water loop;

Typical Water Connection

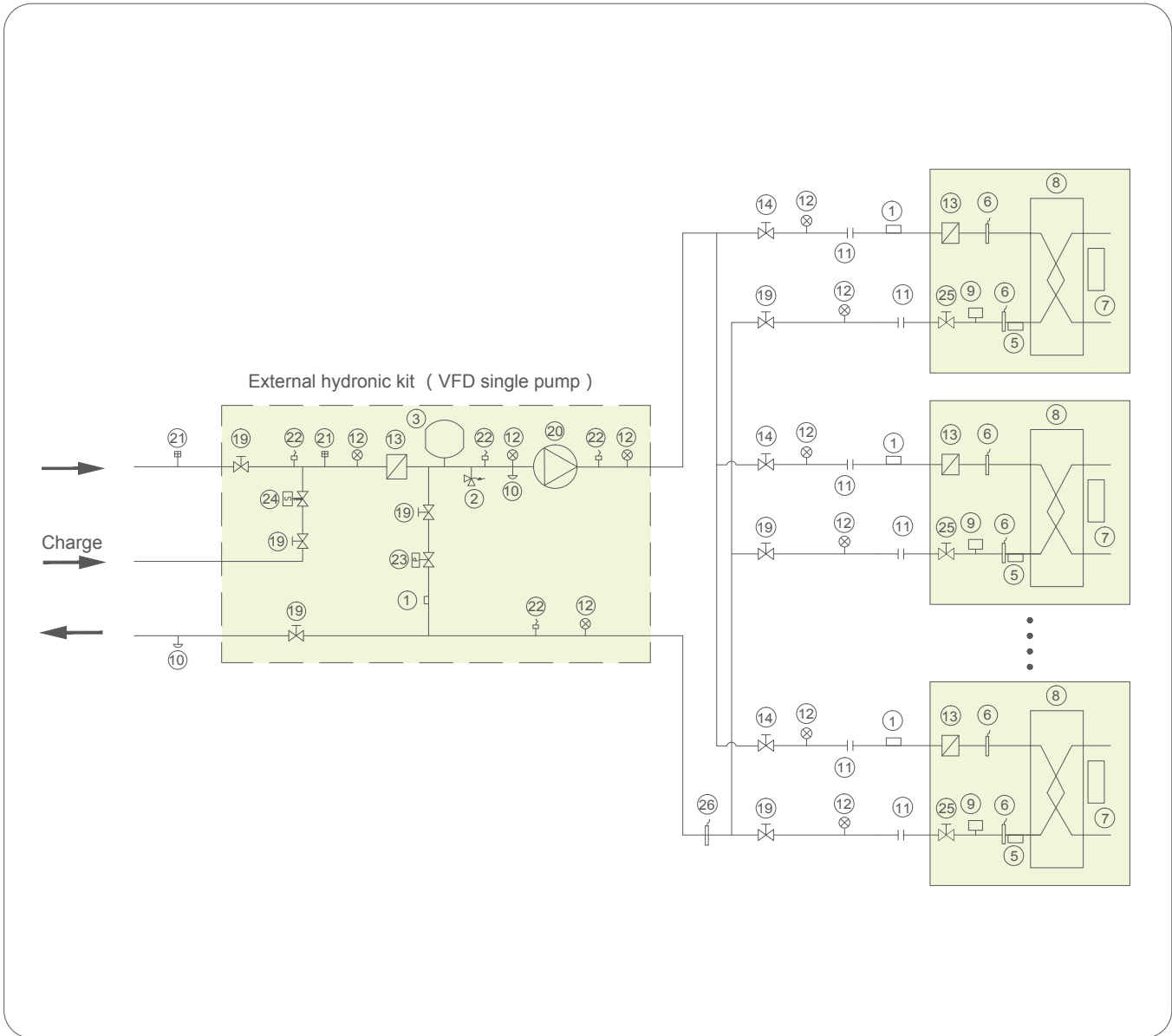

Unit components	Installation components	
	Included in kit	Not included in kit
5 Drain screw plug	2 Safety valve	1 Manual air vent
6 Temperature sensor	3 Expansion tank	11 Flexible connection
7 BPHE heater	10 Drain valve	14 Flow control valve**
8 Brazed plate exchanger	12 Pressur gauge	19 Stop valve
9 Flow switch*	13 Filter	21 Auto air vent
13 Filter	18 Check valve	
	20 Pump	
	21 Auto air vent	
	22 Pressure sensor	
	23 Digital bypass valve	
	24 Auto charge valve ***	

* 30RB/RQ065 Unit flow switch is installed at BPHE outlet;

** Recommend flow regulating valve as butterfly valve or sluice valve etc. instead of stop valves like ball valve;

***Air vent valves should be installed at the highest point of water loop. Drain valve must be installed at the lowest point of water loop;

Water Connection Layout Recommendation

Classified by the arrangement of water supply and return pipes, water system for air conditioning could be direct return or reversed return.

Direct return system: water flow is first-in first-out, so each module will have different pipe length and pressure drop. The direct return system advantages in its simple layout, easy installation and low cost. Due to the different water loop length of each module, the flow regulation valve for each is required to balance the pressure, which ensures the appropriate flow allocation.

Reversed return system: water travels almost the same distance for each module connected in parallel. Each module will have uniform flow rate thanks to the similar water pressure drop. It is always recommended to apply reversed return water system (see below schematics for 30RB/RQ065 multiple module operation).

If not more than 8 modules are connected, Carrier recommends reversed return water system for balancing water allocation. For those jobsites with limited space, direct return water system sometimes is considered and the flow regulation valve must be installed in each module water loop to uniform flow rate. Moreover, when defining the pump size, customer needs to take full account of the extra pressure drop generated by adjusting valve. If more than 8 modules are stacked up, reversed return water system layout is mandatory.

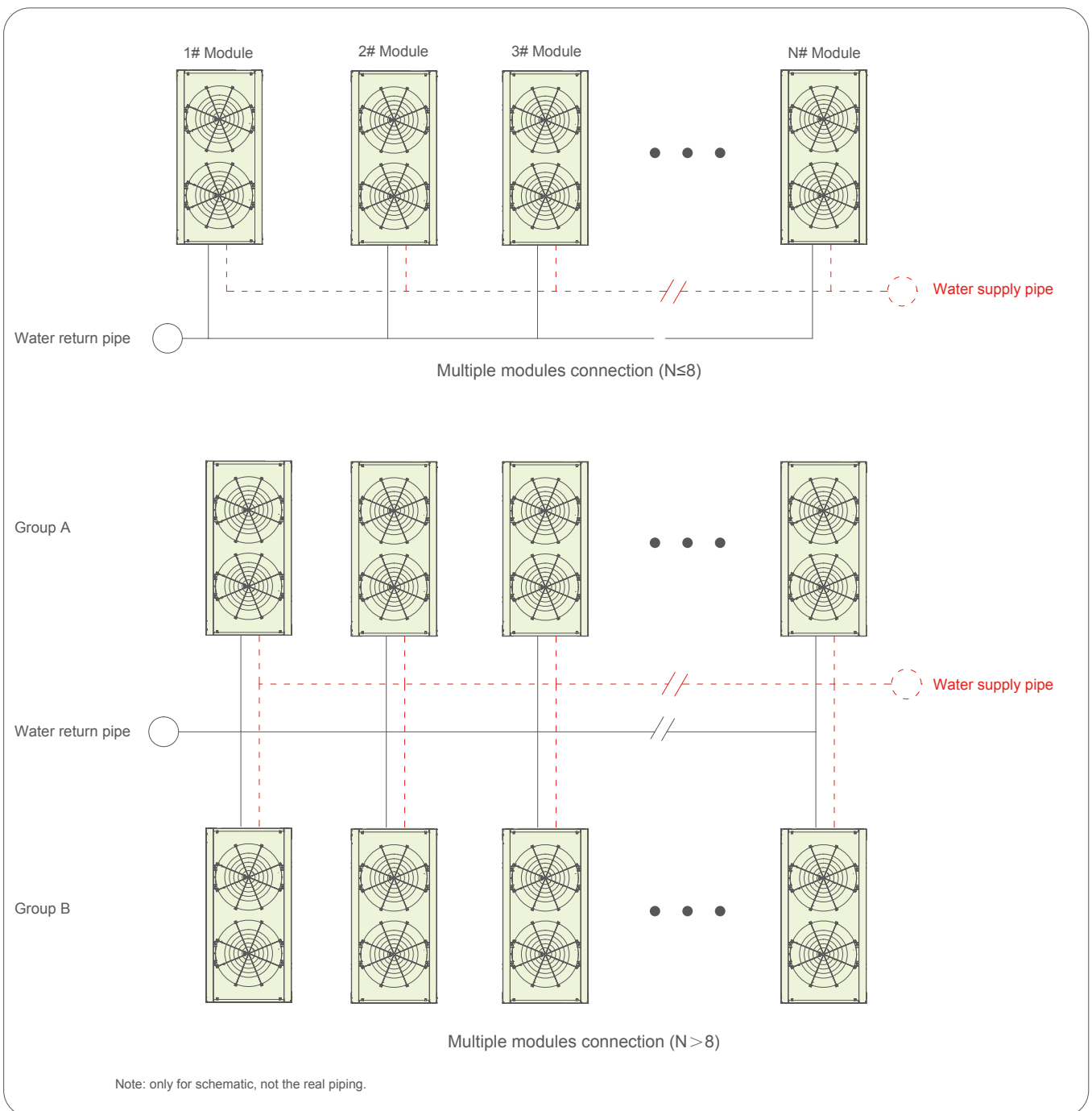

Water Side Performance Diagram

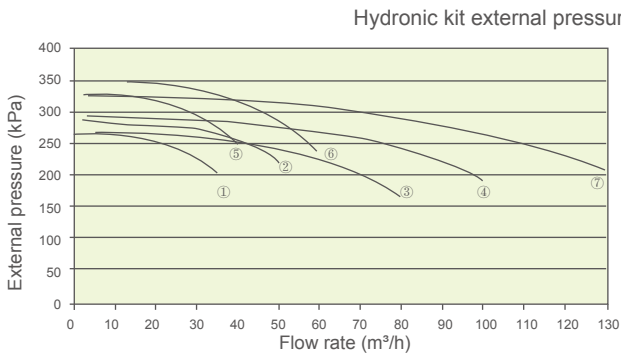
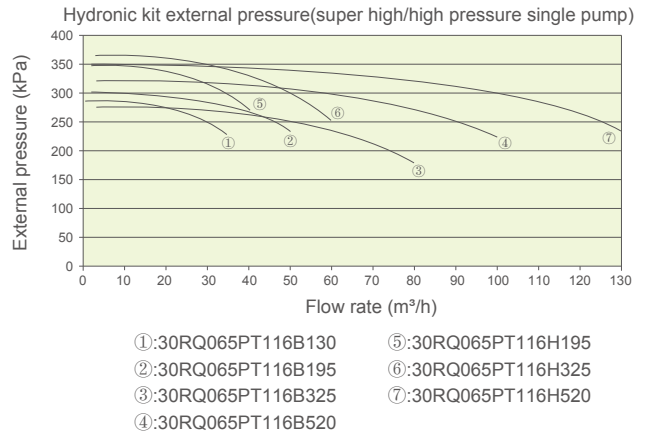
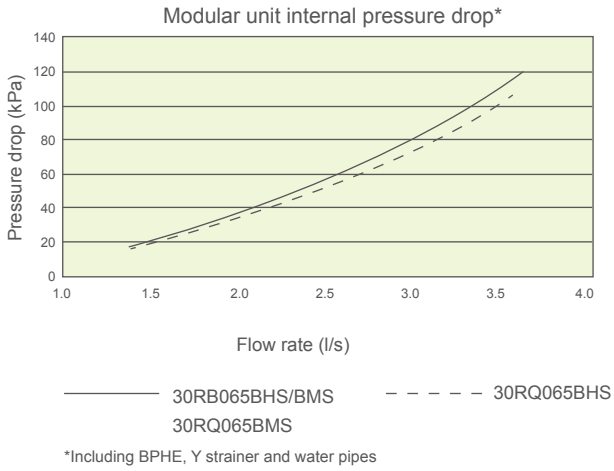

Hydronic kit external pressure(high pressure VFD single pump)

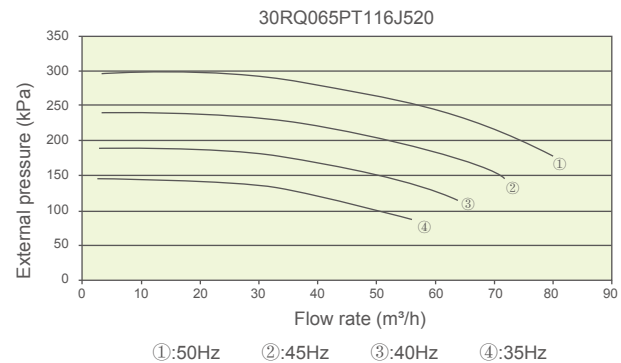
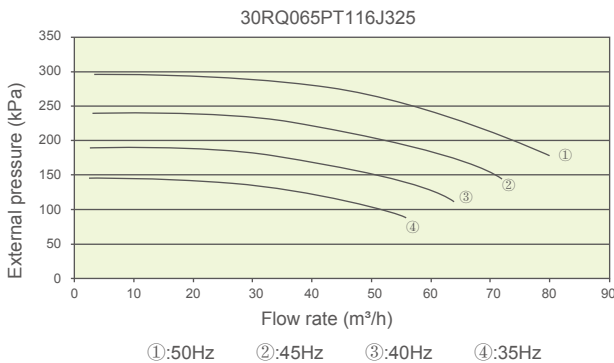
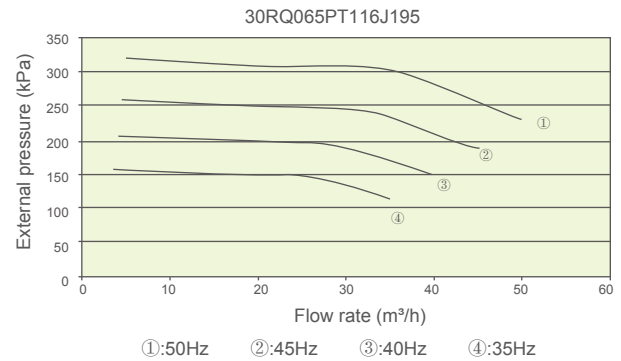
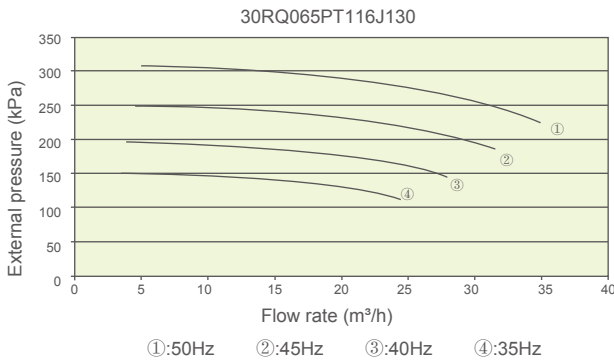

Minimum Water Loop Volume

For better control of leaving water temperature, the water loop minimum capacity is given by the formula:

$$\text{Capacity} = \text{CAP (kW)} \times \text{N Liters}$$

CAP: Unit's nominal cooling capacity

Application		N
Comfort air conditioning	30RB/RQ	3.5
Process cooling	30RB/RQ	Should be greater than 3.5 for better water temperature control

It is often necessary to add a buffer water tank to the circuit in order to achieve the required volume. The tank must itself be internally baffled in order to ensure proper mixing of the liquid (water or brine). Refer to the examples below.

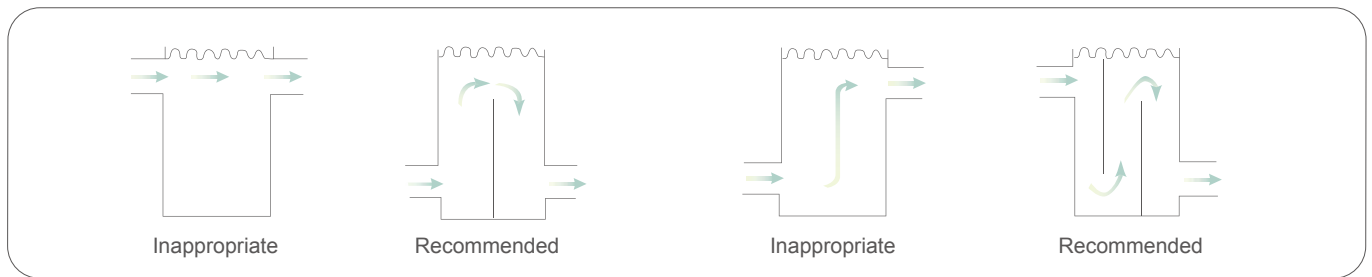

Field wiring diagram (modular unit)

30RB/RQ

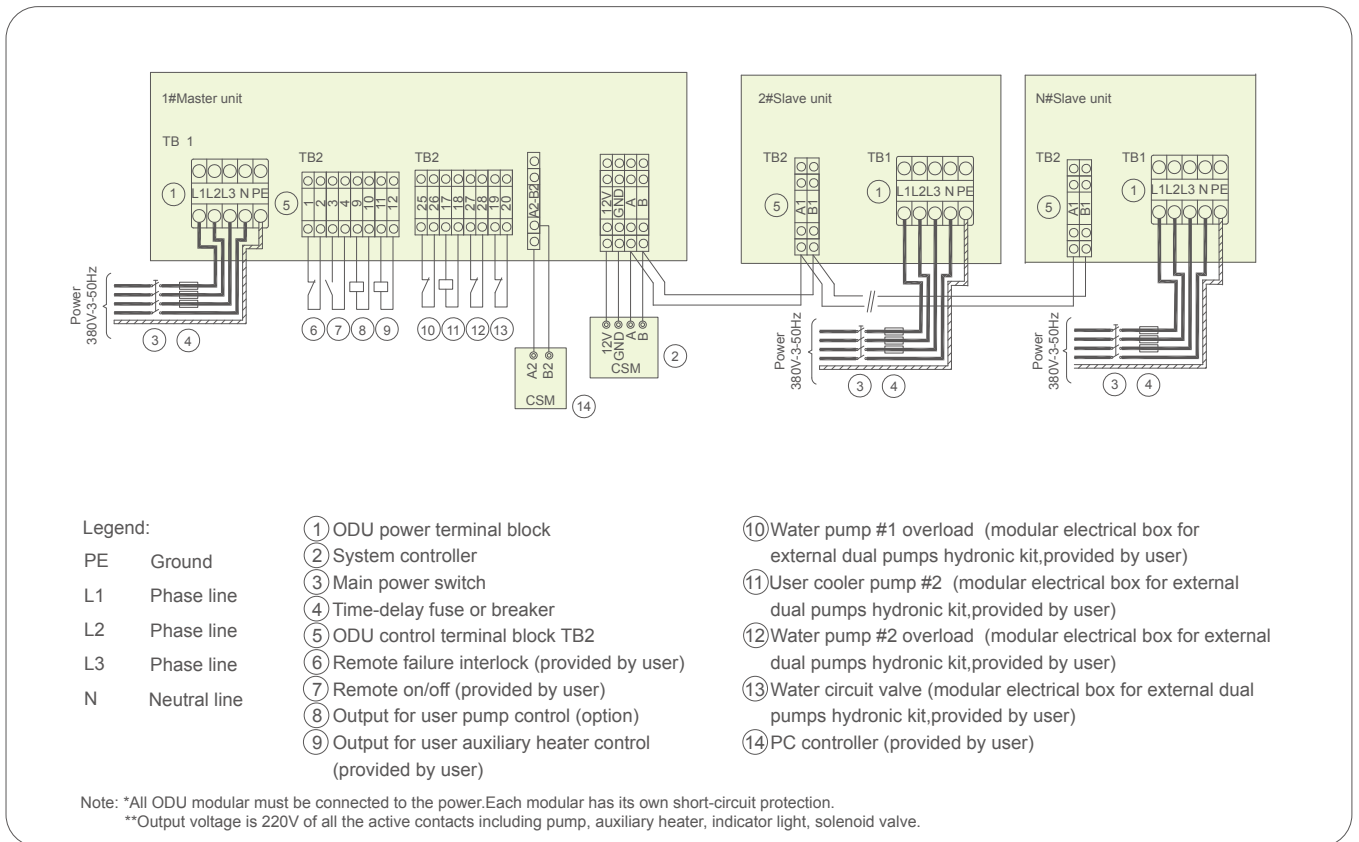

Field wiring diagram (modular unit)



Field wiring diagram (external hydronic kit)

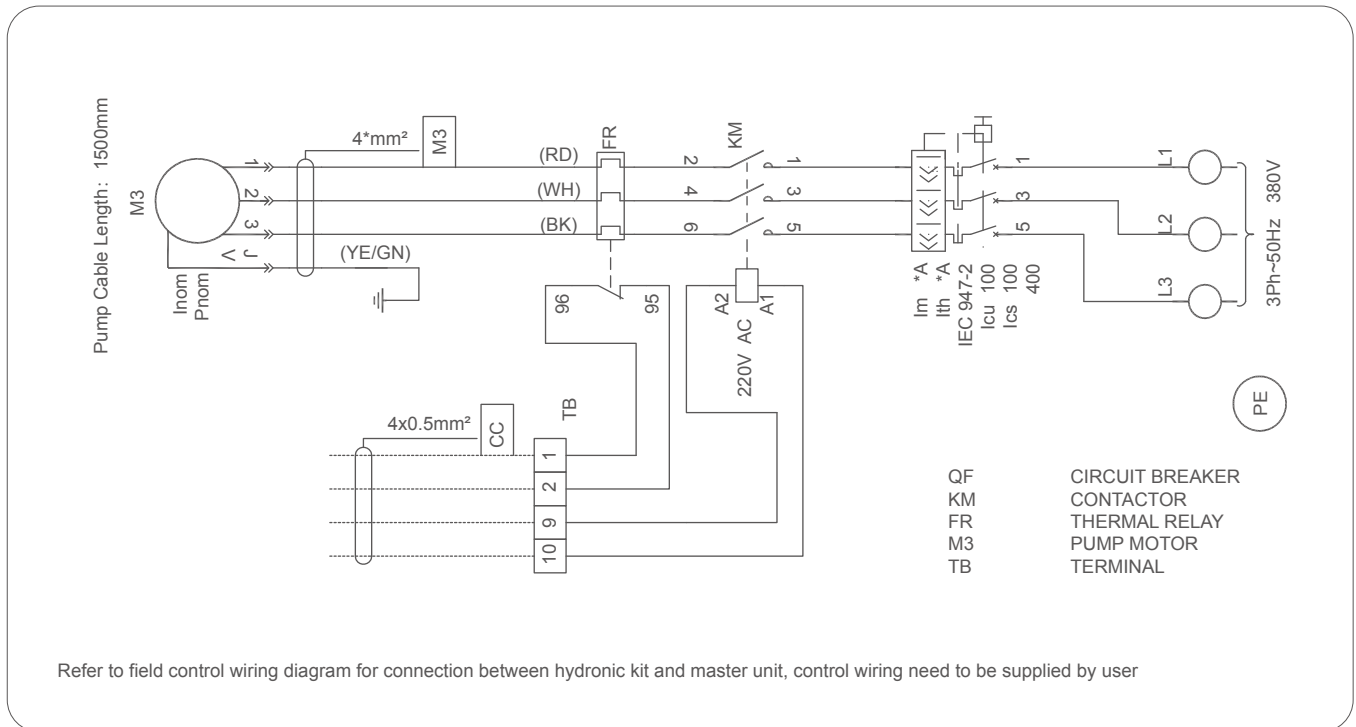



Carrier improves the world around us; Carrier improves people's lives; our products and services improve building performance; our culture of improvement will not allow us to rest when it comes to the environment.



www.carrier.com

The Manufacturer reserves the right to change any product specifications without prior notices
© All Rights Reserved Carrier

Version:	CAT_30RBRQ_E-1808-04(M)
Supersede:	CAT_30RBRQ_E-1405-03(M)
Effective Date:	Aug, 2018