

WATER-COOLED SCREW CHILLERS WATER-SOURCED SCREW HEAT PUMPS

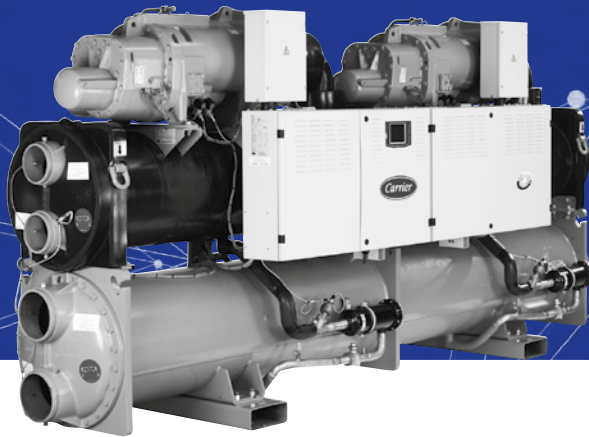

Low energy consumption
High reliability
Easy and fast installation
Low operating sound levels
Environmental care

30XW/30XW-P "A" 30XWH/30XWHP "A"

Nominal cooling capacity 273-1756 kW
Nominal heating capacity 317-1989 kW

The 30XW liquid chillers are the premium solution for industrial and commercial applications where installers, consultants and building owners require optimal performances and maximum quality.

The 30XW liquid chillers are designed to meet current and future requirements in terms of energy efficiency, flexibility of use and compactness. They use the most reliable technologies available today:

- Twin-rotor screw compressors with a variable capacity valve
- Refrigerant R134a
- Touch Pilot control system
- Flooded heat exchangers that are mechanically cleanable

To meet to all environmental and economic requirements, the 30XW is available in two efficiency classes:

- Entry-level efficiency 30XW units that offer an optimised balance of technical and economical aspects,
- Premium-efficiency 30XW-P units that offer unequalled energy efficiency to satisfy the most stringent demands of building owners wanting to reduce operating costs to the minimum.

The 30XW Aquaforce range is also split into two versions:

- 30XW for air conditioning and refrigeration applications
- 30XWH for heating applications

As standard, the unit can provide an evaporator leaving temperature down to 3,3°C (-12°C optional), and when operating as a heat pump, it can deliver up to 50°C (63°C optional) on the condenser side.

AQUAFORCE



CARRIER participates in the ECP programme for LCP/HP
Check ongoing validity of certificate:
www.eurovent-certification.com

CUSTOMER BENEFITS

Low energy consumption

- SEPR up to 8,0 and SEER up to 7,2
- The high energy efficiency is reached through:
 - Twin-rotor screw compressor equipped with a high-efficiency motor and a variable capacity valve that permits exact matching of the cooling capacity to the load.
 - Flooded multi-pipe heat exchangers for increased heat exchange efficiency.
 - Electronic expansion device permitting operation at a lower condensing pressure and improved utilisation of the evaporator heat exchange surface.
 - Economizer system with electronic expansion device for increased cooling capacity (30XW-P).

Low operating sound levels

- Standard unit features include:
 - Silencers on the compressors discharge line.
 - Silencers on the economiser return line.
 - Acoustic insulation on the components that are most subjected to radiated noise.
 - Operation 257 further reduces the global unit sound level.

Easy and fast installation

- Compact design
 - The 30XW units are designed to offer the most compact dimensions on the market.
 - With a width of approximately 1 m up to 1600 kW the units can pass through standard door openings and only require minimum floor space in the plant room.

Compact, accessible unit - side view - sizes up to 1600 KW

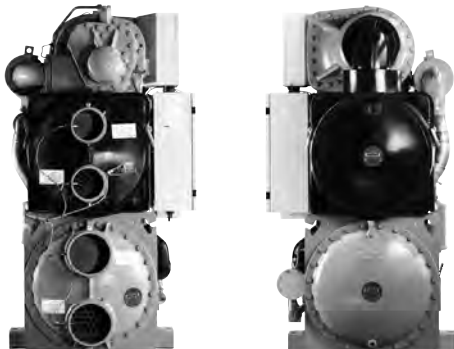

- Simplified electrical connections
 - Main disconnect switch with high trip capacity
 - Transformer to supply the integrated control circuit (400/24 V)
- Simplified hydraulic connections
 - Victaulic connections on the evaporator and condenser
 - Practical reference marks for entering and leaving water connections
 - Possibility to reverse the heat exchanger water inlet and outlet at the factory
 - Possibility to modify the number of heat exchanger passes
- Fast commissioning
 - Systematic factory operation test before shipment
 - Quick-test function for step-by-step verification of the instruments, expansion devices and compressors.

Environmental care

- R-134a refrigerant
 - HFC refrigerant with zero ozone depletion potential
- Leak-tight refrigerant circuit
 - Reduction of leaks as no capillary tubes and flare connections are used
 - Verification of pressure transducers and temperature sensors without transferring refrigerant charge
 - Discharge line shut-off valve and liquid line service valve for simplified maintenance.

High reliability and easy servicing

- The 30XW units offer increased global performance as well as Carrier's acclaimed product quality and reliability.
- Major components are selected and tested to minimize failures possibility, as well as many design choices have been taken in this perspective.
- Screw compressors
 - Industrial-type screw compressors with oversized bearings and motor cooled by suction gas.
 - All compressor components are easily accessible on site minimising down-time.
- Refrigerant circuit
 - Two independent refrigerant circuits (from 1000 kW upwards); the second one automatically takes over, if the first one develops a fault, maintaining partial cooling under all circumstances.
- Evaporator
 - Electronic paddle-free flow switch. Auto-setting according to cooler size and fluid type.
- Auto-adaptive control
 - Control algorithm prevents excessive compressor cycling (Carrier patent)
 - Automatic compressor unloading in case of abnormally high condensing pressure.
- Exceptional endurance tests
 - Partnerships with specialised laboratories and use of limit simulation tools (finite element calculation) for the design of critical components.
 - Transport simulation test in the laboratory on a vibrating table and then on an endurance circuit (based on a military standard).

TECHNICAL INSIGHTS

Touch Pilot Control

Touch Pilot control, 5" user interface



- New innovative smart control features:
 - An intuitive and user-friendly, coloured, 5" interface (7» optional)
 - Direct access to the unit's technical drawings and the main service documents
 - Screen-shots with concise and clear information in local languages
 - Complete menu, customised for different users (end user, service personnel and Carrier-factory technicians)
 - Easy access to the controller box with inclined touch screen mounting to ensure legibility under any lighting conditions
 - Safe operation and unit setting: password protection ensures that unauthorised people cannot modify any advanced parameters
 - Simple and «smart» intelligence uses data collection from the constant monitoring of all machine parameters to optimise unit operation.
- Energy management:
 - Internal time schedule clock controls chiller on/off times and operation at a second set-point
 - The DCT (Data Collection Tool) records the alarms history to simplify and facilitate service operations.

Remote Management (Standard)

- Units with Touch Pilot control can be easily accessed from the internet, using a PC with an Ethernet connection. This makes remote control quick and easy and offers significant advantages for service operations.
- The 30XW also communicates with other building management systems via optional communication gateways.
- The 30XW is equipped with an RS485 serial port that offers multiple remote control, monitoring and diagnostic possibilities. Carrier offers a vast choice of control products, specially designed to control, manage and supervise the operation of an air conditioning system. Please consult your Carrier representative for more information.
- The following commands/visualisations are possible from remote connection:
 - Condenser pumps control: a digital input allows verification of condenser water flow (the flow switch must be supplied by the installer)
 - Start/stop of the machine
 - Dual set-point management: through a dedicated contact is possible to activate a second set-point (example: unoccupied mode)
 - Demand limit setting: to limit the maximum chiller capacity to a predefined value
 - Operation visualization: indication if the unit is operating or if it's in stand-by (no cooling load) alarm visualization.

Remote management (EMM option)

- The Energy Management Module offers extended remote control possibilities:
 - Room temperature: permits set-point reset based on the building indoor air temperature (with Carrier thermostat)
 - Set point reset: ensures reset of the cooling set-point based on a 4-20 mA signal
 - Demand limit: permits limitation of the maximum chiller power or current based on a 4-20 mA signal
 - Demand limit 1 and 2: closing of these contacts limits the maximum chiller power or current to two predefined values
 - User safety: this contact can be used for any customer safety loop; opening of the contact generates a specific alarm
 - Ice storage end: when ice storage has finished, this input permits return to the second set-point (unoccupied mode)
 - Time schedule override: closing of this contact cancels the time schedule effects
 - Out of service: this signal indicates that the chiller is completely out of service
 - Chiller capacity: this analogue output (0-10 V) gives an immediate indication of the chiller capacity
 - Alert indication: this volt-free contact indicates the necessity to carry out a maintenance operation or the presence of a minor fault.

06T screw compressor



The new generation of the Carrier 06T screw compressors benefits from Carrier's long experience in the development of twin-rotor screw compressors. The compressor is equipped with bearings with oversized rollers, oil pressure lubricated for reliable and durable operation, even at maximum load.

A variable control valve controlled by the oil pressure permits infinitely variable cooling capacity. This system allows optimal adjustment of the compressor cooling capacity and ensures exceptionally high stability of the chilled water leaving temperature.

Among the other advantages: if a fault occurs e.g. if the condenser is fouled or at very high water temperature, the compressor does not switch off, but continues operation with a reduced capacity (unloaded mode).

The silencer in the discharge line considerably reduces discharge gas pulsations for much quieter operation.

The condenser includes an oil separator that minimises the amount of oil in circulation in the refrigerant circuit and re-directs it to the compressor function.

OPTIONS

Options	No.	Description	Advantages	Use
Medium-temperature brine solution	5	Implementation of new algorithms of control and evaporator redesign to allow chilled brine solution production down to -6°C when ethylene glycol is used (-3°C with propylene glycol)	Covers specific applications such as ice storage and industrial processes	Only sizes 512/562/1012/1154
Low-temperature brine solution	6	Implementation of new algorithms of control and evaporator redesign to allow chilled brine solution production down to -12°C when ethylene glycol is used (-8°C with propylene glycol)	Covers specific applications such as ice storage and industrial processes	Only sizes 512/562/1012/1154
Light-brine solution, down to -3°C	8	Implementation of new algorithms of control to allow chilled brine solution production down to -3°C when ethylene glycol is used (0°C with propylene glycol)	Matches with most application requirements for ground-sourced heat pumps and fits with many industrial processes requirements	254-1762
Unit supplied in two assembled parts	51	The unit is equipped with flanges that allow disassembly of the unit on site	Facilitates installation in plant rooms with limited access	Only sizes 1612/1652/1702/1762
Master/slave operation	58	Unit equipped with supplementary water outlet temperature sensor kit to be field-installed allowing master/slave operation of two units connected in parallel	Optimised operation of two chillers connected in parallel with operating time equalisation	254-1762
Single power connection point	81	Unit power connection via one main supply connection	Quick and easy installation	1002-1762
No disconnect switch, but short circuit protection	82A	Unit without disconnect switch, but with short-circuit protection device	Permits an external electrical disconnect system for the unit (field-supplied), while ensuring unit short circuit protection	254-1762
Evaporator pump electrical power / control circuit	84	Unit equipped with an electrical power and control circuit for one pump evaporator side	Quick and easy installation: the control of fixed speed pumps is embedded in the unit control	254-1252, 1314
Evaporator dual pumps electrical power / control circuit	84D	Unit equipped with an electrical power and control circuit for two pumps evaporator side	Quick and easy installation: the control of fixed speed pumps is embedded in the unit control	254-1252, 1314
Condenser pump electrical power / control circuit	84R	Unit equipped with an electrical power and control circuit for one pump condenser side	Quick and easy installation: the control of fixed speed pumps is embedded in the unit control	254-1252, 1314
Condenser insulation	86	Thermal condenser insulation	Minimizes thermal dispersions condenser side (key option for heat pump or heat recovery applications) and allows compliancy with special installation criteria (hot parts insulated)	254-1762
Service valve set	92	Liquid line valve (evaporator inlet) and compressor suction line valve	Allow isolation of various refrigerant circuit components for simplified service and maintenance	254-1762
Evaporator with one pass	100C	Evaporator with one pass on the water side. Evaporator inlet and outlet on opposite sides.	Easy to install, depending on site. Reduced pressure drops	254-1762
Condenser with one pass	102C	Condenser with one pass on the water side. Condenser inlet and outlet on opposite sides.	Easy to install, depending on site. Reduced pressure drops	254-1762
21 bar evaporator	104	Reinforced evaporator for extension of the maximum water-side service pressure to 21 bar (standard 10 bar)	Covers applications with a high water column evaporator side (typically high buildings)	254-1762
21 bar condenser	104A	Reinforced condenser for extension of the maximum water-side service pressure to 21 bar (standard 10 bar)	Covers applications with a high water column condenser side (typically high buildings)	254-1762
Reversed evaporator water connections	107	Evaporator with reversed water inlet/outlet	Easy installation on sites with specific requirements	254-1762
Reversed condenser water connections	107A	Condenser with reversed water inlet/outlet	Easy installation on sites with specific requirements	254-1762

OPTIONS

Options	No.	Description	Advantages	Use
JBus gateway	148B	Two-directional communication board complying with JBus protocol	Connects the unit by communication bus to a building management system	254-1762
LON gateway	148D	Two-directional communication board complying with Lon Talk protocol	Connects the unit by communication bus to a building management system	254-1762
Bacnet over IP gateway	149	Two-directional high-speed communication using BACnet protocol over Ethernet network (IP)	Easy and high-speed connection by ethernet line to a building management system. Allows access to multiple unit parameters	254-1762
High condensing temperature	150	Optimized compressor for operation at high condensing temperature	Increased condenser leaving water temperature up to 63°C. Allows applications with high condensing temperature (heat pumps, installations with not generously sized dry-coolers or more generally, installations with dry-coolers in hot climate). NOTE: to ensure control of the condenser leaving water temperature, this option must be fitted with 30XWH units.	30XWH- / XW-P / XWHP 254-1762 & 30XW--254/304/354
Condensing temperature limitation	150B	Limitation of the maximum condenser leaving water temperature to 45°C	Reduced maximum power input and current absorption: power cables and protection elements can therefore be downsized	254-1762
Control for low condensing temperature systems	152	Output signal (0-10 V) to control the condenser water inlet valve	Simple installation: for applications with cold water at condenser inlet (ex. ground-source, groundwater-source, superficial water-source applications) the signal permits to control a 2 or 3-way valve to maintain condenser water temperature (and so condensing pressure) at acceptable values	254-1762
Energy Management Module EMM	156	Control board with additional inputs/outputs. See Energy Management Module option chapter	Extended remote control capabilities (Set-point reset, ice storage end, demand limits, boiler on/off command...)	254-1762
Touch Pilot control, 7" user interface	158A	Touch Pilot control supplied with a 7 inch colour touch screen user interface	Enhanced ease of use	254-1762
Leak detection	159	0-10 V signal to report any refrigerant leakage in the unit directly on the controller (the leak detector itself must be supplied by the customer)	Immediate customer notification of refrigerant losses to the atmosphere, allowing timely corrective actions	254-1762
Compliance with Swiss regulations	197	Additional tests on the water heat exchangers: supply (additional of PED documents) supplementary certificates and test certifications	Conformance with Swiss regulations	254-1762
Compliance with Australian regulations	200	Unit approved to Australian code	Conformance with Australian regulations	254-1762
Low noise level	257	Evaporator sound insulation	3 dB(A) quieter than standard unit	254-1762
Welded evaporator water connection kit	266	Victaulic piping connections with welded joints	Easy installation	254-1762
Welded condenser water connection kit	267	Victaulic piping connections with welded joints	Easy installation	254-1762
Flanged evaporator water connection kit	268	Victaulic piping connections with flanged joints	Easy installation	254-1762
Flanged condenser water connection kit	269	Victaulic piping connections with flanged joints	Easy installation	254-1762
Thermal compressor insulation	271	The compressor is covered with a thermal insulation layer	Prevents air humidity to condensate on the compressor surface	254-1762
230V electrical plug	284	230V AC power supply source provided with plug socket and transformer (180 VA, 0,8 Amps)	Permits connection of a laptop or an electrical device during unit commissioning or servicing	254-1762
Carrier Connect link (BSS regions only)	298	3G router board NOTE 1: require option 149 NOTE 2: when more than one machine is installed on site, only one of them shall be equipped with option 298 while all of them must be equipped with option 149 NOTE 3: if a CARRIER-PSM is on site, option 298 shall be integrated in the PSM while option 149 is still mandatory for each single unit.	Enabler for Carrier Connect service offer	254-1762

PHYSICAL DATA, STANDARD UNITS

Standard-efficiency units

30XW--/30XWH-	254	304	354	402	452	552	602	652	702	802
---------------	-----	-----	-----	-----	-----	-----	-----	-----	-----	-----

Heating

Standard unit Full load performances*	HW1	Nominal capacity	kW	323	365	428	546	560	632	642	799	864	941
		COP	kW/kW	6,07	6,07	6,02	5,96	6,09	5,92	5,89	6,10	5,99	5,86
	HW2	Nominal capacity	kW	317	358	421	516	529	599	632	751	813	887
		COP	kW/kW	4,59	4,57	4,61	4,54	4,59	4,47	4,52	4,56	4,49	4,46
Seasonal energy efficiency**	HW1	SCOP _{30/35°C}	kWh/kWh	5,94	6,05	5,83	5,88	5,92	5,92	5,79	6,07	6,01	5,83
		η _{s heat 30/35°C}	%	230	234	225	227	229	229	224	235	232	225
		P _{rated}	kW	382	432	507	650	666	748	760	952	1029	1102

Cooling

Standard unit Full load performances*	CW1	Nominal capacity	kW	273	307	359	459	473	532	538	677	730	792
		EER	kW/kW	5,32	5,30	5,24	5,21	5,35	5,21	5,17	5,39	5,30	5,19
		Eurovent class	-	A	A	A	A	A	A	A	A	A	A
	CW2	Nominal capacity	kW	345	365	458	585	566	596	656	845	884	887
		EER	kW/kW	6,71	6,24	6,57	6,40	6,28	5,74	6,21	6,50	6,21	5,70
		Eurovent class	-	A	A	A	A	A	A	A	A	A	A
Seasonal energy efficiency		SEER _{12/7°C} Comfort low temp.	kWh/kWh	5,84	5,80	5,64	5,77	5,75	5,81	5,77	6,20	6,13	5,87
		η _{s cool 12/7°C}	%	231	229	223	228	227	229	228	245	242	232
		SEPR _{12/7°C} Process high temp.	kWh/kWh	7,57	6,92	7,66	7,47	7,58	6,56	7,28	7,91	7,54	7,30
		SEER _{23/18°C} Comfort medium temp.	kWh/kWh	6,76	6,60	6,50	6,22	6,05	6,57	6,31	6,87	6,70	6,42
Integrated Part Load Value	IPLV,SI	kW/kW	6,843	6,708	6,722	6,664	6,897	6,905	6,891	7,351	7,321	7,184	

Sound levels - standard unit

Sound power level ⁽¹⁾	dB(A)	95	95	95	99	99	99	99	99	99	99	99
Sound pressure level at 1 m ⁽²⁾	dB(A)	78	78	78	82	82	82	82	82	82	82	82

Sound levels - standard unit + option 257⁽³⁾

Sound power level ⁽¹⁾	dB(A)	-	-	-	96	96	96	96	96	96	96	96
Sound pressure level at 1 m ⁽²⁾	dB(A)	-	-	-	78	78	78	78	78	78	78	78

Dimensions - standard unit

Length	mm	2724	2724	2724	2741	2741	2741	2741	3059	3059	3059
Width	mm	928	928	928	936	936	936	936	1040	1040	1040
Height	mm	1567	1567	1567	1692	1692	1692	1692	1848	1848	1848

Operating weight ⁽⁴⁾

Operating weight ⁽⁴⁾	kg	2017	2036	2072	2575	2575	2613	2644	3247	3266	3282
Compressors		Semi-hermetic 06T screw compressors, 50 r/s									
Circuit A	-	1	1	1	1	1	1	1	1	1	1
Circuit B	-	-	-	-	-	-	-	-	-	-	-

- * In accordance with standard EN14511-3:2013.
- ** In accordance with standard EN14825:2013, average climate
- HW1 Heating mode conditions: Evaporator entering/leaving water temperature 10°C/7°C, condenser entering/leaving water temperature 30°C/35°C, evaporator and condenser fouling factor 0 m². k/W
- HW2 Heating mode conditions: Evaporator entering/leaving water temperature 10°C/7°C, condenser entering/leaving water temperature 40°C/45°C, evaporator and condenser fouling factor 0 m². k/W
- CW1 Cooling mode conditions: Evaporator water entering/leaving temperature 12°C/7°C, condenser entering/leaving water temperature 30°C/35°C, evaporator and condenser fouling factor 0 m².K/W
- CW2 Cooling mode conditions: Evaporator water entering/leaving temperature 23°C/18°C, condenser entering/leaving water temperature 30°C/35°C, evaporator and condenser fouling factor 0 m².K/W
- η_{s heat 30/35°C} & SCOP_{30/35°C} Applicable Ecodesign regulation: (EU) No 813/2013
- η_{s cool 12/7°C} & SEER_{12/7°C} **Applicable Ecodesign regulation: (EU) No 2016/2281**
- SEPR_{12/7°C} **Applicable Ecodesign regulation: (EU) No 2016/2281**
- SEER_{23/18°C} Applicable Ecodesign regulation: (EU) No 2016/2281
- IPLV,SI Calculations according to standard performances AHRI 551-591.
- (1) In dB ref=10⁻¹² W, (A) weighting. Declared dualnumber noise emission values in accordance with ISO 4871 (with an associated uncertainty of +/-3dB(A)). Measured in accordance with ISO 9614-1 and certified by Eurovent.
- (2) In dB ref 20μPa, (A) weighting. Declared dualnumber noise emission values in accordance with ISO 4871 (with an associated uncertainty of +/-3dB(A)). For information, calculated from the sound power level Lw(A).
- (3) Option 257 = Low noise level.
- (4) Weight shown is guideline only. Please refer to the unit nameplate.



Eurovent certified values



AHRI certified values
30XW-only

PHYSICAL DATA, STANDARD UNITS

Standard-efficiency units

30XW--/30XWH-		254	304	354	402	452	552	602	652	702	802
Refrigerant ⁽⁴⁾		R-134a									
Circuit A	kg	84	80	78	82	82	82	82	145	135	125
	teqCO ₂	120	114	112	117	117	117	117	207	193	179
Circuit B	kg	-	-	-	-	-	-	-	-	-	-
	teqCO ₂	-	-	-	-	-	-	-	-	-	-
Oil - standard unit		SW220									
Circuit A	l	23,5	23,5	23,5	32	32	32	32	36	36	36
Circuit B	l	-	-	-	-	-	-	-	-	-	-
Capacity control		Touch Pilot, electronic expansion valves (EXV)									
Minimum capacity ⁽⁵⁾	%	15	15	15	15	15	15	15	15	15	15
Evaporator		Multi-pipe flooded type									
Water volume	l	50	56	61	70	70	70	70	109	109	109
Water connections (Victaulic)	in	5	5	5	5	5	5	5	6	6	6
Drain and vent connections (NPT)	in	3/8	3/8	3/8	3/8	3/8	3/8	3/8	3/8	3/8	3/8
Max. water-side operating pressure	kPa	1000	1000	1000	1000	1000	1000	1000	1000	1000	1000
Condenser		Multi-pipe flooded type									
Water volume	l	55	55	55	76	76	76	76	109	109	109
Water connections (Victaulic)	in	5	5	5	5	5	5	5	6	6	6
Drain and vent connections (NPT)	in	3/8	3/8	3/8	3/8	3/8	3/8	3/8	3/8	3/8	3/8
Max. water-side operating pressure	kPa	1000	1000	1000	1000	1000	1000	1000	1000	1000	1000

(4) Weight shown is guideline only. Please refer to the unit nameplate.

(5) Minimum unit capacity corresponds to a physical state of the unit and is given for indication only. The actual capacity at this stage depends on operating conditions.

PHYSICAL DATA, STANDARD UNITS

Standard-efficiency units

30XW--/30XWH-	852	1002	1052	1154	1252	1352	1452	1552	1652	1702
---------------	-----	------	------	------	------	------	------	------	------	------

Heating

Standard unit Full load performances*	HW1	Nominal capacity	kW	992	1204	1258	1349	1473	1578	1714	1829	1941	2027
		COP	kW/kW	6,04	5,88	5,79	5,89	6,26	6,03	5,84	5,73	6,01	5,98
	HW2	Nominal capacity	kW	967	1138	1190	1320	1384	1481	1612	1717	1891	1969
		COP	kW/kW	4,64	4,48	4,42	4,54	4,73	4,57	4,46	4,41	4,67	4,68
Seasonal energy efficiency**	HW1	SCOP _{30/35°C}	kWh/kWh	5,90	6,05	5,96	5,99	6,19	5,84	5,64	5,47	5,73	5,70
		η _s heat _{30/35°C}	%	228	234	231	232	240	226	218	211	221	220
		P _{rated}	kW	1160	1433	1498	1599	1754	1879	2041	2178	2292	2389

Cooling

Standard unit Full load performances*	CW1	Nominal capacity	kW	839	1017	1060	1141	1257	1342	1453	1547	1654	1728
		EER	kW/kW	5,39	5,26	5,21	5,30	5,69	5,51	5,36	5,29	5,59	5,60
		Eurovent class	-	A	A	A	A	A	A	A	A	A	A
	CW2	Nominal capacity	kW	922	1297	1348	1351	1678	1837	1916	1903	1944	2009
		EER	kW/kW	5,84	6,44	6,33	6,13	7,25	7,12	6,70	6,25	6,36	6,30
		Eurovent class	-	A	A	A	A	A	A	A	A	A	A
Seasonal energy efficiency		SEER _{12/7°C} Comfort low temp.	kWh/kWh	6,27	6,47	6,53	6,44	7,14	6,93	6,75	6,63	7,05	7,03
		η _s cool _{12/7°C}	%	248	256	258	255	283	274	267	262	279	278
		SEPR _{12/7°C} Process high temp.	kWh/kWh	6,97	7,56	7,47	7,17	8,42	8,19	7,61	7,43	7,44	7,32
		SEER _{23/18°C} Comfort medium temp.	kWh/kWh	6,68	7,30	7,24	7,13	8,11	8,05	7,72	7,20	7,67	7,56
Integrated Part Load Value	IPLV.SI	kW/kW	7,175	7,539	7,751	7,596	8,066	7,835	7,730	7,575	7,957	7,892	

Sound levels - standard unit

Sound power level ⁽¹⁾	dB(A)	99	102	102	102	102	102	102	102	102	102	102
Sound pressure level at 1 m ⁽²⁾	dB(A)	82	84	84	84	83	83	83	83	83	83	83

Sound levels - standard unit + option 257⁽³⁾

Sound power level ⁽¹⁾	dB(A)	96	99	99	99	99	99	99	99	99	99	99
Sound pressure level at 1 m ⁽²⁾	dB(A)	78	80	80	80	80	80	80	80	80	80	80

Dimensions - standard unit

Length	mm	2780	4025	4025	4025	4730	4730	4730	4730	4790	4790
Width	mm	1042	1036	1036	1036	1156	1156	1156	1156	1902	1902
Height	mm	1898	1870	1870	1925	2051	2051	2051	2051	1515	1515

Operating weight ⁽⁴⁾

Operating weight ⁽⁴⁾	kg	3492	5370	5408	5698	7066	7267	7305	7337	8681	8699
Compressors		Semi-hermetic 06T screw compressors, 50 r/s									
Circuit A	-	1	1	1	1	1	1	1	1	1	1
Circuit B	-	-	1	1	1	1	1	1	1	1	1

- * In accordance with standard EN14511-3:2013.
- ** In accordance with standard EN14825:2013, average climate
- HW1 Heating mode conditions: Evaporator entering/leaving water temperature 10°C/7°C, condenser entering/leaving water temperature 30°C/35°C, evaporator and condenser fouling factor 0 m². k/W
- HW2 Heating mode conditions: Evaporator entering/leaving water temperature 10°C/7°C, condenser entering/leaving water temperature 40°C/45°C, evaporator and condenser fouling factor 0 m². k/W
- CW1 Cooling mode conditions: Evaporator water entering/leaving temperature 12°C/7°C, condenser entering/leaving water temperature 30°C/35°C, evaporator and condenser fouling factor 0 m².K/W
- CW2 Cooling mode conditions: Evaporator water entering/leaving temperature 23°C/18°C, condenser entering/leaving water temperature 30°C/35°C, evaporator and condenser fouling factor 0 m².K/W
- η_s heat_{30/35°C} & SCOP_{30/35°C} Applicable Ecodesign regulation: (EU) No 813/2013
- η_s cool_{12/7°C} & SEER_{12/7°C} **Applicable Ecodesign regulation: (EU) No 2016/2281**
- SEPR_{12/7°C} **Applicable Ecodesign regulation: (EU) No 2016/2281**
- SEER_{23/18°C} Applicable Ecodesign regulation: (EU) No 2016/2281
- IPLV.SI Calculations according to standard performances AHRI 551-591.
- (1) In dB ref=10⁻¹² W, (A) weighting. Declared dualnumber noise emission values in accordance with ISO 4871 (with an associated uncertainty of +/-3dB(A)). Measured in accordance with ISO 9614-1 and certified by Eurovent.
- (2) In dB ref 20μPa, (A) weighting. Declared dualnumber noise emission values in accordance with ISO 4871 (with an associated uncertainty of +/-3dB(A)). For information, calculated from the sound power level Lw(A).
- (3) Option 257 = Low noise level.
- (4) Weight shown is guideline only. Please refer to the unit nameplate.



Eurovent certified values



AHRI certified values
30XW-only

PHYSICAL DATA, STANDARD UNITS

Standard-efficiency units

30XW--/30XWH-		852	1002	1052	1154	1252	1352	1452	1552	1652	1702
Refrigerant ⁽⁴⁾		R-134a									
Circuit A	kg	158	85	85	105	120	115	110	105	195	195
	teqCO ₂	226	122	122	150	172	164	157	150	279	279
Circuit B	kg	-	85	85	105	120	115	110	105	195	195
	teqCO ₂	-	122	122	150	172	164	157	150	279	279
Oil - standard unit		SW220									
Circuit A	l	36	32	32	32	36	36	36	36	36	36
Circuit B	l	-	32	32	32	32	36	36	36	36	36
Capacity control		Touch Pilot, electronic expansion valves (EXV)									
Minimum capacity ⁽⁵⁾	%	15	10	10	10	10	10	10	10	10	10
Evaporator		Multi-pipe flooded type									
Water volume	l	98	182	182	205	301	301	301	301	354	354
Water connections (Victaulic)	in	6	6	6	8	8	8	8	8	8	8
Drain and vent connections (NPT)	in	3/8	3/8	3/8	3/8	3/8	3/8	3/8	3/8	3/8	3/8
Max. water-side operating pressure	kPa	1000	1000	1000	1000	1000	1000	1000	1000	1000	1000
Condenser		Multi-pipe flooded type									
Water volume	l	137	193	193	193	340	340	340	340	426	426
Water connections (Victaulic)	in	8	8	8	8	8	8	8	8	8	8
Drain and vent connections (NPT)	in	3/8	3/8	3/8	3/8	3/8	3/8	3/8	3/8	3/8	3/8
Max. water-side operating pressure	kPa	1000	1000	1000	1000	1000	1000	1000	1000	1000	1000

(4) Weight shown is guideline only. Please refer to the unit nameplate.

(5) Minimum unit capacity corresponds to a physical state of the unit and is given for indication only. The actual capacity at this stage depends on operating conditions.

PHYSICAL DATA, STANDARD UNITS

High-efficiency units

30XW-P/30XWHP			512	562	712	812	862	1012	1162	1314	1464	1612	1762	
Heating														
Standard unit Full load performances*	HW1	Nominal capacity	kW	596	676	860	923	1009	1216	1352	1545	1705	1890	2048
		COP	kW/kW	6,48	6,39	6,58	6,36	6,35	6,42	6,35	6,38	6,14	6,46	6,35
	HW2	Nominal capacity	kW	583	662	842	904	982	1191	1320	1509	1663	1846	1989
		COP	kW/kW	4,91	4,84	4,97	4,80	4,85	4,90	4,86	4,89	4,71	4,89	4,87
Seasonal energy efficiency**	HW1	SCOP _{30/35°C}	kWh/kWh	6,27	6,33	6,50	6,27	6,27	6,43	6,37	6,22	6,01	6,38	6,29
		η _{s heat 30/35°C}	%	243	245	252	243	243	249	247	241	232	247	244
		P _{rated}	kW	706	802	1019	1093	1196	1441	1600	1831	2021	2241	2428
Cooling														
Standard unit Full load performances*	CW1	Nominal capacity	kW	509	577	737	786	861	1039	1157	1323	1452	1626	1756
		EER	kW/kW	5,71	5,64	5,83	5,62	5,65	5,73	5,78	5,80	5,58	5,87	5,79
		Eurovent class	-	A	A	A	A	A	A	A	A	A	A	A
	CW2	Nominal capacity	kW	616	705	936	1007	1088	1251	1395	1683	1926	2062	2215
		EER	kW/kW	6,85	6,81	7,24	7,00	6,92	6,85	6,83	7,14	7,10	7,21	7,00
		Eurovent class	-	A	A	A	A	A	A	A	A	A	A	A
Seasonal energy efficiency		SEER _{12/7°C Comfort low temp.}	kWh/kWh	5,79	6,02	6,6	6,37	6,28	6,75	7,17	7	6,83	7,27	7,25
		η _{s cool 12/7°C}	%	229	238	261	252	248	267	284	277	270	288	287
		SEPR _{12/7°C Process high temp.}	kWh/kWh	7,87	7,91	8,13	7,69	7,53	7,88	7,99	8,16	7,84	8,02	7,66
		SEER _{23/18°C Comfort medium temp.}	kWh/kWh	7,88	6,90	7,69	8,26	7,32	7,66	8,01	7,84	7,76	8,52	8,13
Integrated Part Load Value	IPLV.SI	kW/kW	7,323	7,468	7,666	7,513	7,439	7,747	8,125	8,068	7,852	8,201	7,900	
Sound levels - standard unit														
Sound power level ⁽¹⁾	dB(A)	99	99	99	99	99	102	102	102	102	102	102	102	
Sound pressure level at 1 m ⁽²⁾	dB(A)	82	82	81	81	81	83	83	83	83	83	83	83	
Sound levels - standard unit + option 257⁽³⁾														
Sound power level ⁽¹⁾	dB(A)	96	96	96	96	96	99	99	99	99	99	99	99	
Sound pressure level at 1 m ⁽²⁾	dB(A)	78	78	78	78	78	80	80	80	80	80	80	80	
Dimensions - standard unit														
Length	mm	3059	3059	3290	3290	3290	4730	4730	4730	4730	4730	4832	4832	
Width	mm	936	936	1069	1069	1069	1039	1039	1162	1162	1162	2129	2129	
Height	mm	1743	1743	1950	1950	1950	1997	1997	2051	2051	2051	1562	1562	
Operating weight ⁽⁴⁾	kg	2981	3020	3912	3947	3965	6872	6950	7542	7752	10910	10946	10946	
Compressors														
Semi-hermetic 06T screw compressors, 50 r/s														
Circuit A	-	1	1	1	1	1	1	1	1	1	1	1	1	
Circuit B	-	-	-	-	-	-	1	1	1	1	1	1	1	

- * In accordance with standard EN14511-3:2013.
- ** In accordance with standard EN14825:2013, average climate
- HW1 Heating mode conditions: Evaporator entering/leaving water temperature 10°C/7°C, condenser entering/leaving water temperature 30°C/35°C, evaporator and condenser fouling factor 0 m². k/W
- HW2 Heating mode conditions: Evaporator entering/leaving water temperature 10°C/7°C, condenser entering/leaving water temperature 40°C/45°C, evaporator and condenser fouling factor 0 m². k/W
- CW1 Cooling mode conditions: Evaporator water entering/leaving temperature 12°C/7°C, condenser entering/leaving water temperature 30°C/35°C, evaporator and condenser fouling factor 0 m².K/W
- CW2 Cooling mode conditions: Evaporator water entering/leaving temperature 23°C/18°C, condenser entering/leaving water temperature 30°C/35°C, evaporator and condenser fouling factor 0 m².K/W
- η_{s heat 30/35°C} & SCOP_{30/35°C} Applicable Ecodesign regulation: (EU) No 813/2013
- η_{s cool 12/7°C} & SEER_{12/7°C} **Applicable Ecodesign regulation: (EU) No 2016/2281**
- SEPR_{12/7°C} **Applicable Ecodesign regulation: (EU) No 2016/2281**
- SEER_{23/18°C} Applicable Ecodesign regulation: (EU) No 2016/2281
- IPLV.SI Calculations according to standard performances AHRI 551-591.
- (1) In dB ref=10⁻¹² W, (A) weighting. Declared dualnumber noise emission values in accordance with ISO 4871 (with an associated uncertainty of +/-3dB(A)). Measured in accordance with ISO 9614-1 and certified by Eurovent.
- (2) In dB ref 20μPa, (A) weighting. Declared dualnumber noise emission values in accordance with ISO 4871 (with an associated uncertainty of +/-3dB(A)). For information, calculated from the sound power level Lw(A).
- (3) Option 257 = Low noise level.
- (4) Weight shown is guideline only. Please refer to the unit nameplate.



Eurovent certified values



AHRI certified values
30XW-only

PHYSICAL DATA, STANDARD UNITS

High-efficiency units

30XW-P/30XWHP		512	562	712	812	862	1012	1162	1314	1464	1612	1762
Refrigerant ⁽⁴⁾		R-134a										
Circuit A	kg	130	130	180	175	170	120	120	130	130	240	250
	teqCO ₂	186	186	257	250	243	172	172	186	186	343	358
Circuit B	kg	-	-	-	-	-	120	120	150	130	240	250
	teqCO ₂	-	-	-	-	-	172	172	215	186	343	358
Oil - standard unit												
Circuit A	l	32	32	36	36	36	32	32	36	36	36	36
Circuit B	l	-	-	-	-	-	32	32	32	36	36	36
Capacity control		Touch Pilot, electronic expansion valves (EXV)										
Minimum capacity ⁽⁵⁾	%	15	15	15	15	15	10	10	10	10	10	10
Evaporator		Multi-pipe flooded type										
Water volume	l	101	101	154	154	154	293	293	321	321	473	473
Water connections (Victaulic)	in	6	6	8	8	8	8	8	8	8	10	10
Drain and vent connections (NPT)	in	3/8	3/8	3/8	3/8	3/8	3/8	3/8	3/8	3/8	3/8	3/8
Max. water-side operating pressure	kPa	1000	1000	1000	1000	1000	1000	1000	1000	1000	1000	1000
Condenser		Multi-pipe flooded type										
Water volume	l	103	103	148	148	148	316	316	340	340	623	623
Water connections (Victaulic)	in	6	6	8	8	8	8	8	8	8	10	10
Drain and vent connections (NPT)	in	3/8	3/8	3/8	3/8	3/8	3/8	3/8	3/8	3/8	3/8	3/8
Max. water-side operating pressure	kPa	1000	1000	1000	1000	1000	1000	1000	1000	1000	1000	1000

(4) Weight shown is guideline only. Please refer to the unit nameplate.

(5) Minimum unit capacity corresponds to a physical state of the unit and is given for indication only. The actual capacity at this stage depends on operating conditions.

ELECTRICAL DATA, STANDARD UNITS

Standard-efficiency units

30XW--/30XWH-		254	304	354	402	452	552	602	652	702	802
Power circuit											
Nominal power supply	V-ph-Hz	400-3-50									
Voltage range	V	360-440									
Control circuit											
24 V via the built-in transformer											
Nominal start-up current*											
Circuit A	A	233	233	303	414	414	414	414	587	587	587
Circuit B	A	-	-	-	-	-	-	-	-	-	-
Option 81	A	-	-	-	-	-	-	-	-	-	-
Maximum start-up current**											
Circuit A	A	233	233	303	414	414	414	414	587	587	587
Circuit B	A	-	-	-	-	-	-	-	-	-	-
Option 81	A	-	-	-	-	-	-	-	-	-	-
Cosine phi											
Nominal***		0.83	0.85	0.83	0.87	0.88	0.89	0.89	0.88	0.89	0.90
Maximum****		0.89	0.89	0.88	0.90	0.90	0.91	0.91	0.90	0.91	0.92
Total harmonic distortion****	%	0	0	0	0	0	0	0	0	0	0
Maximum power input†											
Circuit A	kW	76	89	97	128	135	151	151	184	200	223
Circuit B	kW	-	-	-	-	-	-	-	-	-	-
Option 81	kW	-	-	-	-	-	-	-	-	-	-
Nominal current drawn***											
Circuit A	A	84	96	113	136	144	162	162	193	214	232
Circuit B	A	-	-	-	-	-	-	-	-	-	-
Option 81	A	-	-	-	-	-	-	-	-	-	-
Maximum current drawn (Un)†											
Circuit A	A	123	145	160	206	217	242	242	295	317	351
Circuit B	A	-	-	-	-	-	-	-	-	-	-
Option 81	A	-	-	-	-	-	-	-	-	-	-
Maximum current drawn (Un -10%)****											
Circuit A	A	138	162	178	218	230	260	260	304	340	358
Circuit B	A	-	-	-	-	-	-	-	-	-	-
Option 81	A	-	-	-	-	-	-	-	-	-	-
Maximum power input with option 150B†											
Circuit A	kW	67	79	87	114	118	133	134	173	183	205
Circuit B	kW	-	-	-	-	-	-	-	-	-	-
Option 81	kW	-	-	-	-	-	-	-	-	-	-
Maximum current drawn (Un) with option 150B†											
Circuit A	A	109	129	142	183	191	212	212	278	290	325
Circuit B	A	-	-	-	-	-	-	-	-	-	-
Option 81	A	-	-	-	-	-	-	-	-	-	-

* Instantaneous start-up current (maximum operating current of the smallest compressor(s) + locked rotor current or reduced start-up current of the largest compressor). Values obtained at standard Eurovent unit operating conditions: evaporator entering/leaving water temperature = 12°C/7°C, condenser entering/leaving water temperature = 30°C/35°C.

** Instantaneous start-up current (maximum operating current of the smallest compressor(s) + locked rotor current or reduced start-up current of the largest compressor). Values obtained at operation with maximum unit power input.

*** Values obtained at standard Eurovent unit operating conditions: evaporator entering/leaving water temperature = 12°C/7°C, condenser entering/leaving water temperature = 30°C/35°C

**** Values obtained at operation with maximum unit power input.

† Values obtained at operation with maximum unit power input. Values given on the unit name plate.

ELECTRICAL DATA, STANDARD UNITS

Standard-efficiency units

30XW--/30XWH-		852	1002	1052	1154	1252	1352	1452	1552	1652	1702
Power circuit											
Nominal power supply	V-ph-Hz	400-3-50									
Voltage range	V	360-440									
Control circuit											
24 V via the built-in transformer											
Nominal start-up current*											
Circuit A	A	587	414	414	414	587	587	587	587	587	587
Circuit B	A	-	414	414	414	414	587	587	587	587	587
Option 81	A	-	558	574	574	747	780	801	819	819	819
Maximum start-up current**											
Circuit A	A	587	414	414	414	587	587	587	587	587	587
Circuit B	A	-	414	414	414	414	587	587	587	587	587
Option 81	A	-	631	656	656	829	882	904	938	938	938
Cosine phi											
Nominal***		0.90	0.88	0.89	0.89	0.88	0.88	0.89	0.9	0.9	0.9
Maximum****		0.92	0.90	0.91	0.91	0.90	0.90	0.91	0.92	0.92	0.92
Total harmonic distortion****	%	0	0	0	0	0	0	0	0	0	0
Maximum power input†											
Circuit A	kW	223	150	151	151	184	184	200	223	223	223
Circuit B	kW	-	135	151	151	151	184	200	223	202	223
Option 81	kW	-	284	301	301	334	367	399	447	425	447
Nominal current drawn***											
Circuit A	A	232	162	162	162	193	193	214	232	232	232
Circuit B	A	-	144	162	162	162	193	214	232	214	232
Option 81	A	-	306	324	324	355	386	427	464	446	464
Maximum current drawn (Un)†											
Circuit A	A	351	242	242	242	295	295	317	351	351	351
Circuit B	A	-	217	242	242	242	295	317	351	317	351
Option 81	A	-	459	484	484	537	590	634	702	668	702
Maximum current drawn (Un -10%)****											
Circuit A	A	358	260	260	260	304	304	340	358	358	358
Circuit B	A	-	230	260	260	260	304	340	358	340	358
Option 81	A	-	490	520	520	564	608	680	716	698	716
Maximum power input with option 150B†											
Circuit A	kW	205	133	133	133	173	173	183	207	207	207
Circuit B	kW	-	118	133	133	133	173	183	207	185	207
Option 81	kW	-	251	265	265	305	346	365	414	391	414
Maximum current drawn (Un) with option 150B†											
Circuit A	A	325	212	212	212	278	278	290	325	325	325
Circuit B	A	-	191	212	212	212	278	290	325	290	325
Option 81	A	-	403	424	424	490	556	580	650	615	650

* Instantaneous start-up current (maximum operating current of the smallest compressor(s) + locked rotor current or reduced start-up current of the largest compressor). Values obtained at standard Eurovent unit operating conditions: evaporator entering/leaving water temperature = 12°C/7°C, condenser entering/leaving water temperature = 30°C/35°C.

** Instantaneous start-up current (maximum operating current of the smallest compressor(s) + locked rotor current or reduced start-up current of the largest compressor). Values obtained at operation with maximum unit power input.

*** Values obtained at standard Eurovent unit operating conditions: evaporator entering/leaving water temperature = 12°C/7°C, condenser entering/leaving water temperature = 30°C/35°C

**** Values obtained at operation with maximum unit power input.

† Values obtained at operation with maximum unit power input. Values given on the unit name plate.

ELECTRICAL DATA, STANDARD UNITS

High-efficiency units

30XW-P/30XWHP		512	562	712	812	862	1012	1162	1314	1464	1612	1762
Power circuit												
Nominal power supply	V-ph-Hz	400-3-50										
Voltage range	V	360-440										
Control circuit												
24 V via the built-in transformer												
Nominal start-up current*												
Circuit A	A	414	414	587	587	587	414	414	587	587	587	587
Circuit B	A	-	-	-	-	-	414	414	414	587	587	587
Option 81	A	-	-	-	-	-	556	574	747	780	801	819
Maximum start-up current**												
Circuit A	A	414	414	587	587	587	414	414	587	587	587	587
Circuit B	A	-	-	-	-	-	414	414	414	587	587	587
Option 81	A	-	-	-	-	-	631	656	829	882	904	938
Cosine phi												
Nominal***		0.88	0.89	0.88	0.89	0.90	0.86	0.87	0.88	0.88	0.89	0.90
Maximum****		0.90	0.90	0.90	0.91	0.92	0.89	0.90	0.90	0.90	0.91	0.92
Total harmonic distortion****	%	0	0	0	0	0	0	0	0	0	0	0
Maximum power input†												
Circuit A	kW	135	151	184	200	223	134	151	184	184	200	223
Circuit B	kW	-	-	-	-	-	134	151	151	184	200	223
Option 81	kW	-	-	-	-	-	267	301	334	367	399	447
Nominal current drawn***												
Circuit A	A	144	162	193	214	232	144	162	193	193	214	232
Circuit B	A	-	-	-	-	-	144	162	162	193	214	232
Option 81	A	-	-	-	-	-	288	324	355	386	427	464
Maximum current drawn (Un)†												
Circuit A	A	217	242	295	317	351	217	242	295	295	317	351
Circuit B	A	-	-	-	-	-	217	242	242	295	317	351
Option 81	A	-	-	-	-	-	434	484	537	590	634	702
Maximum current drawn (Un -10%)****												
Circuit A	A	230	260	304	340	358	230	260	304	304	340	358
Circuit B	A	-	-	-	-	-	230	260	260	304	340	358
Option 81	A	-	-	-	-	-	460	520	564	608	680	716
Maximum power input with option 150B†												
Circuit A	kW	118	133	173	183	207	118	133	173	173	183	207
Circuit B	kW	-	-	-	-	-	118	133	133	173	183	207
Option 81	kW						235	265	305	346	365	414
Maximum current drawn (Un) with option 150B†												
Circuit A	A	191	212	278	290	325	191	212	278	278	290	325
Circuit B	A	-	-	-	-	-	191	212	212	278	290	325
Option 81	A	-	-	-	-	-	382	424	490	556	580	650

* Instantaneous start-up current (maximum operating current of the smallest compressor(s) + locked rotor current or reduced start-up current of the largest compressor). Values obtained at standard Eurovent unit operating conditions: evaporator entering/leaving water temperature = 12°C/7°C, condenser entering/leaving water temperature = 30°C/35°C.

** Instantaneous start-up current (maximum operating current of the smallest compressor(s) + locked rotor current or reduced start-up current of the largest compressor). Values obtained at operation with maximum unit power input.

*** Values obtained at standard Eurovent unit operating conditions: evaporator entering/leaving water temperature = 12°C/7°C, condenser entering/leaving water temperature = 30°C/35°C

**** Values obtained at operation with maximum unit power input.

† Values obtained at operation with maximum unit power input. Values given on the unit name plate.

PHYSICAL DATA, UNITS FOR HIGH CONDENSING TEMPERATURES

Standard-efficiency units (option 150)

30XW--/30XWH-	254	304	354	402	452	552	602	652	702	802
---------------	-----	-----	-----	-----	-----	-----	-----	-----	-----	-----

Heating

Unit + option 150 Full load performances*	HW1	Nominal capacity	kW	334	373	421	511	542	607	626	769	847	890
		COP	kW/kW	5,59	5,59	5,54	5,22	5,47	5,36	5,48	5,39	5,38	5,3
	HW2	Nominal heating capacity	kW	325	362	408	478	506	566	606	716	789	829
		COP	kW/kW	4,62	4,59	4,55	4,29	4,50	4,43	4,54	4,45	4,45	4,41
	HW3	Nominal capacity	kW	316	352	396	446	471	527	587	665	734	773
		COP	kW/kW	3,85	3,83	3,79	3,50	3,68	3,63	3,78	3,65	3,65	3,63
Seasonal energy efficiency**	HW1	SCOP _{30/35°C}	kWh/kWh	5,81	5,93	5,89	5,57	5,70	5,69	5,62	5,53	5,57	5,30
		η _s heat _{30/35°C}	%	224	229	227	215	220	220	217	213	215	204
	HW3	SCOP _{47/55°C}	kWh/kWh	4,56	4,61	4,55	4,20	4,37	4,41	4,42	4,24	4,31	4,46
		η _s heat _{47/55°C}	%	174	176	174	160	167	169	169	162	164	170
	P _{rated}		kW	416	419	473	540	571	638	700	807	890	936

Cooling

Unit + option 150 Full load performances*	CW1	Nominal cooling capacity	kW	282	313	352	NA	NA	NA	NA	NA	NA	NA
		EER	kW/kW	4,89	4,87	4,82	NA	NA	NA	NA	NA	NA	NA
		Eurovent class		B	B	B	NA	NA	NA	NA	NA	NA	NA
Seasonal energy efficiency	SEER_{12/7°C} Comfort low temp.		kWh/kWh	5,76	5,83	5,80	NA	NA	NA	NA	NA	NA	NA
	η _s cool _{12/7°C}		%	227	230	229	NA	NA	NA	NA	NA	NA	NA
	SEPR_{12/7°C} Process high temp.		kWh/kWh	6,45	6,49	6,35	NA	NA	NA	NA	NA	NA	NA
Integrated Part Load Value	IPLV.SI		kW/kW	6,491	6,657	6,658	NA	NA	NA	NA	NA	NA	NA

Sound levels - unit with option 150

Sound power level ⁽¹⁾	dB(A)	95	95	95	99	99	99	99	102	102	102
Sound pressure level at 1 m ⁽²⁾	dB(A)	78	78	78	82	82	82	82	84	84	84

Sound levels - unit with option 150 + option 257⁽³⁾

Sound power level ⁽¹⁾	dB(A)	-	-	-	96	96	96	96	100	100	100
Sound pressure level at 1 m ⁽²⁾	dB(A)	-	-	-	78	78	78	78	82	82	82

Dimensions - unit with option 150

Length	mm	2724	2724	2724	2741	2741	2741	2741	3059	3059	3059
Width	mm	928	928	928	936	936	936	936	1090	1090	1090
Height	mm	1567	1567	1567	1692	1692	1692	1692	1858	1858	1858
Operating weight ⁽⁴⁾	kg	2017	2036	2072	2575	2575	2613	2644	3407	3438	3462

Compressors

		Semi-hermetic 06T screw compressors, 50 r/s									
Circuit A	-	1	1	1	1	1	1	1	1	1	1
Circuit B	-	-	-	-	-	-	-	-	-	-	-

- * In accordance with standard EN14511-3:2013.
- ** In accordance with standard EN14825:2013, average climate
- HW1 Heating mode conditions: Evaporator entering/leaving water temperature 10°C/7°C, condenser entering/leaving water temperature 30°C/35°C, evaporator and condenser fouling factor 0 m². kW
- HW2 Heating mode conditions: Evaporator entering/leaving water temperature 10°C/7°C, condenser entering/leaving water temperature 40°C/45°C, evaporator and condenser fouling factor 0 m². kW
- HW3 Heating mode conditions: Evaporator entering/leaving water temperature 10°C/7°C, condenser entering/leaving water temperature 47°C/55°C, evaporator and condenser fouling factor 0 m². kW
- CW1 Cooling mode conditions: Evaporator water entering/leaving temperature 12°C/7°C, condenser entering/leaving water temperature 30°C/35°C, evaporator and condenser fouling factor 0 m². kW
- η_s heat_{30/35°C} & SCOP_{30/35°C} Applicable Ecodesign regulation: (EU) No 813/2013
- η_s heat_{47/55°C} & SCOP_{47/55°C} Applicable Ecodesign regulation: (EU) No 813/2013
- η_s cool_{12/7°C} & SEER_{12/7°C} **Applicable Ecodesign regulation: (EU) No 2016/2281**
- SEPR_{12/7°C} **Applicable Ecodesign regulation: (EU) No 2016/2281**
- IPLV.SI Calculations according to standard performances AHRI 551-591.
- (1) In dB ref=10⁻¹² W, (A) weighting. Declared dualnumber noise emission values in accordance with ISO 4871 (with an associated uncertainty of +/-3dB(A)). Measured in accordance with ISO 9614-1 and certified by Eurovent.
- (2) In dB ref 20μPa, (A) weighting. Declared dualnumber noise emission values in accordance with ISO 4871 (with an associated uncertainty of +/-3dB(A)). For information, calculated from the sound power level Lw(A).
- (3) Option 257 = Low noise level
- (4) Weight shown is guideline only. Please refer to the unit nameplate



Eurovent certified values

PHYSICAL DATA, UNITS FOR HIGH CONDENSING TEMPERATURES

Standard-efficiency units (option 150)

30XW--/30XWH-		254	304	354	402	452	552	602	652	702	802
Refrigerant ⁽⁴⁾		R-134a									
Circuit A	kg	84	80	78	82	82	82	82	145	135	125
	teqCO ₂	120	114	112	117	117	117	117	207	193	179
Circuit B	kg	-	-	-	-	-	-	-	-	-	-
	teqCO ₂	-	-	-	-	-	-	-	-	-	-
Oil - unit with option 150		SW220									
Circuit A	l	23,5	23,5	23,5	32	32	32	32	36	36	36
Circuit B	l	-	-	-	-	-	-	-	-	-	-
Capacity control		Touch Pilot, electronic expansion valves (EXV)									
Minimum capacity ⁽⁵⁾	%	30	30	30	30	30	30	30	15	15	15
Evaporator		Multi-pipe flooded type									
Water volume	l	50	56	61	70	70	70	70	109	109	109
Water connections (Victaulic)	in	5	5	5	5	5	5	5	6	6	6
Drain and vent connections (NPT)	in	3/8	3/8	3/8	3/8	3/8	3/8	3/8	3/8	3/8	3/8
Max. water-side operating pressure	kPa	1000	1000	1000	1000	1000	1000	1000	1000	1000	1000
Condenser		Multi-pipe flooded type									
Water volume	l	55	55	55	76	76	76	76	109	109	109
Water connections (Victaulic)	in	5	5	5	5	5	5	5	6	6	6
Drain and vent connections (NPT)	in	3/8	3/8	3/8	3/8	3/8	3/8	3/8	3/8	3/8	3/8
Max. water-side operating pressure	kPa	1000	1000	1000	1000	1000	1000	1000	1000	1000	1000

(4) Weight shown is guideline only. Please refer to the unit nameplate

(5) Minimum unit capacity corresponds to a physical state of the unit and is given for indication only. The actual capacity at this stage depends on operating conditions.

PHYSICAL DATA, UNITS FOR HIGH CONDENSING TEMPERATURES

Standard-efficiency units (option 150)

30XW--/30XWH-			852	1002	1052	1154	1252	1352	1452	1552	1652	1702	
Heating													
Unit + option 150 Full load performances*	HW1	Nominal capacity	kW	983	1181	1250	1345	1466	1576	1702	1821	1962	2032
		COP	kW/kW	5,49	5,44	5,37	5,47	5,69	5,4	5,32	5,28	5,45	5,41
	HW2	Nominal heating capacity	kW	958	1099	1163	1294	1348	1465	1583	1678	1904	1975
		COP	kW/kW	4,57	4,52	4,47	4,55	4,71	4,52	4,45	4,45	4,57	4,59
	HW3	Nominal capacity	kW	932	1019	1078	1246	1275	1357	1469	1573	1845	1915
		COP	kW/kW	3,80	3,73	3,69	3,8	3,91	3,71	3,67	3,7	3,85	3,84
Seasonal energy efficiency**	HW1	SCOP _{30/35°C}	kWh/kWh	5,68	5,70	5,61	5,61	5,78	5,42	5,46	5,14	5,52	5,47
		η _{s heat} _{30/35°C}	%	219	220	216	216	223	209	210	198	213	211
	HW3	SCOP _{47/55°C}	kWh/kWh	4,66	4,66	4,63	4,63	4,71	4,43	4,50	4,56	4,70	4,68
		η _{s heat} _{47/55°C}	%	178	178	177	177	181	169	172	175	180	179
		P _{rated}	kW	1111	1237	1309	1490	1549	1648	1783	1907	2203	2285
	Sound levels - unit with option 150												
Sound power level ⁽¹⁾			dB(A)	102	102	102	102	105	105	105	105	105	105
Sound pressure level at 1 m ⁽²⁾			dB(A)	84	84	84	84	86	86	86	86	86	86
Sound levels - unit with option 150 + option 257⁽³⁾													
Sound power level ⁽¹⁾			dB(A)	100	99	99	99	103	103	103	103	103	103
Sound pressure level at 1 m ⁽²⁾			dB(A)	82	80	80	80	84	84	84	84	84	84
Dimensions - unit with option 150													
Length			mm	2780	4025	4025	4025	4730	4730	4730	4730	4790	4790
Width			mm	1090	1036	1036	1036	1201	1201	1201	1201	1947	1947
Height			mm	1920	1870	1870	1925	2071	2071	2071	2071	1535	1535
Operating weight ⁽⁴⁾			kg	3672	5370	5408	5698	7233	7554	7622	7670	9006	9032
Compressors			Semi-hermetic 06T screw compressors, 50 r/s										
Circuit A			-	1	1	1	1	1	1	1	1	1	1
Circuit B			-	-	1	1	1	1	1	1	1	1	1

* In accordance with standard EN14511-3:2013.

** In accordance with standard EN14825:2013, average climate

HW1 Heating mode conditions: Evaporator entering/leaving water temperature 10°C/7°C, condenser entering/leaving water temperature 30°C/35°C, evaporator and condenser fouling factor 0 m². k/W

HW2 Heating mode conditions: Evaporator entering/leaving water temperature 10°C/7°C, condenser entering/leaving water temperature 40°C/45°C, evaporator and condenser fouling factor 0 m². k/W

HW3 Heating mode conditions: Evaporator entering/leaving water temperature 10°C/7°C, condenser entering/leaving water temperature 47°C/55°C, evaporator and condenser fouling factor 0 m². k/W

CW1 Cooling mode conditions: Evaporator water entering/leaving temperature 12°C/7°C, condenser entering/leaving water temperature 30°C/35°C, evaporator and condenser fouling factor 0 m². K/W

η_{s heat} _{30/35°C} & SCOP _{30/35°C} Applicable Ecodesign regulation: (EU) No 813/2013

η_{s heat} _{47/55°C} & SCOP _{47/55°C} Applicable Ecodesign regulation: (EU) No 813/2013

η_{s cool} _{12/7°C} & SEER _{12/7°C} **Applicable Ecodesign regulation: (EU) No 2016/2281**

SEPR _{12/7°C} **Applicable Ecodesign regulation: (EU) No 2016/2281**

IPLV.SI Calculations according to standard performances AHRI 551-591.

(1) In dB ref=10⁻¹² W, (A) weighting. Declared dualnumber noise emission values in accordance with ISO 4871 (with an associated uncertainty of +/-3dB(A)). Measured in accordance with ISO 9614-1 and certified by Eurovent.

(2) In dB ref 20μPa, (A) weighting. Declared dualnumber noise emission values in accordance with ISO 4871 (with an associated uncertainty of +/-3dB(A)). For information, calculated from the sound power level Lw(A).

(3) Option 257 = Low noise level

(4) Weight shown is guideline only. Please refer to the unit nameplate



Eurovent certified values

PHYSICAL DATA, UNITS FOR HIGH CONDENSING TEMPERATURES

Standard-efficiency units (option 150)

30XW--/30XWH-		852	1002	1052	1154	1252	1352	1452	1552	1652	1702
Refrigerant ⁽⁴⁾		R-134a									
Circuit A	kg	158	85	85	105	120	115	110	105	195	195
	teqCO ₂	226	122	122	150	172	164	157	150	279	279
Circuit B	kg	-	85	85	105	120	115	110	105	195	195
	teqCO ₂	-	122	122	150	172	164	157	150	279	279
Oil - unit with option 150		SW220									
Circuit A	l	36	32	32	32	36	36	36	36	36	36
Circuit B	l	-	32	32	32	32	36	36	36	36	36
Capacity control		Touch Pilot, electronic expansion valves (EXV)									
Minimum capacity ⁽⁵⁾	%	15	15	15	15	10	10	10	10	10	10
Evaporator		Multi-pipe flooded type									
Water volume	l	98	182	182	205	301	301	301	301	354	354
Water connections (Victaulic)	in	6	6	6	8	8	8	8	8	8	8
Drain and vent connections (NPT)	in	3/8	3/8	3/8	3/8	3/8	3/8	3/8	3/8	3/8	3/8
Max. water-side operating pressure	kPa	1000	1000	1000	1000	1000	1000	1000	1000	1000	1000
Condenser		Multi-pipe flooded type									
Water volume	l	137	193	193	193	340	340	340	340	426	426
Water connections (Victaulic)	in	8	8	8	8	8	8	8	8	8	8
Drain and vent connections (NPT)	in	3/8	3/8	3/8	3/8	3/8	3/8	3/8	3/8	3/8	3/8
Max. water-side operating pressure	kPa	1000	1000	1000	1000	1000	1000	1000	1000	1000	1000

(4) Weight shown is guideline only. Please refer to the unit nameplate

(5) Minimum unit capacity corresponds to a physical state of the unit and is given for indication only. The actual capacity at this stage depends on operating conditions.

PHYSICAL DATA, UNITS FOR HIGH CONDENSING TEMPERATURES

Standard-efficiency units (option 150)

30XW-P / 30XWHP	512	562	712	812	862	1012	1162	1314	1464	1612	1762
-----------------	-----	-----	-----	-----	-----	------	------	------	------	------	------

Heating

Unit + option 150 Full load performances*	HW1	Nominal capacity	kW	607	676	854	924	995	1208	1397	1537	1723	1909	2028
		COP	kW/kW	5,94	5,95	5,82	5,66	5,87	5,71	5,85	5,64	5,47	5,83	5,88
	HW2	Nominal heating capacity	kW	584	651	828	897	1003	1164	1341	1485	1669	1850	1997
		COP	kW/kW	4,88	4,89	4,81	4,68	4,94	4,73	4,86	4,69	4,58	4,84	4,93
	HW3	Nominal capacity	kW	563	627	801	871	984	1123	1288	1433	1610	1789	1989
		COP	kW/kW	4,02	4,04	3,97	3,87	4,11	3,90	4,02	3,91	3,83	4,00	4,14
Seasonal energy efficiency**	HW1	SCOP _{30/35°C}	kWh/kWh	6,13	6,17	6,38	6,10	6,12	5,88	5,99	5,93	5,92	6,04	6,20
		η _s heat _{30/35°C}	%	237	239	247	236	237	227	232	229	229	234	240
	HW3	SCOP _{47/55°C}	kWh/kWh	4,72	4,78	4,94	4,72	4,97	4,72	4,89	4,81	4,87	5,04	5,06
		η _s heat _{47/55°C}	%	181	183	189	181	191	181	187	185	187	194	194
	P _{rated}		kW	674	750	957	1039	1175	1343	1543	1713	1926	2139	2377

Cooling

Unit + option 150 Full load performances*	CW1	Nominal cooling capacity	kW	517	576	725	781	844	1024	1192	1302	1453	1633	1727
		EER	kW/kW	5,20	5,24	5,09	4,94	5,17	5,05	5,29	5,02	4,89	5,22	5,29
		Eurovent class			A	A	A	B	A	A	A	B	B	A
Seasonal energy efficiency	SEER_{12/7°C} Comfort low temp.		kWh/kWh	6,03	6,14	6,44	6,21	5,75	6,19	6,55	6,38	6,48	6,95	6,55
	η_s cool_{12/7°C}		%	238	242	255	245	227	245	259	252	256	275	259
	SEPR_{12/7°C} Process high temp.		kWh/kWh	6,54	6,56	6,81	6,53	6,63	6,37	6,67	6,67	6,53	6,92	7,00
Integrated Part Load Value	IPLV.SI	kW/kW	6,735	6,920	7,116	6,861	7,056	6,706	7,277	7,156	7,265	7,544	7,818	
Sound levels - unit with option 150														
Sound power level ⁽¹⁾		dB(A)	99	99	102	102	102	102	102	105	105	105	105	105
Sound pressure level at 1 m ⁽²⁾		dB(A)	82	82	84	84	84	83	83	86	86	86	86	86
Sound levels - unit with option 150 + option 257⁽³⁾														
Sound power level ⁽¹⁾		dB(A)	96	96	100	100	100	99	99	103	103	103	103	103
Sound pressure level at 1 m ⁽²⁾		dB(A)	78	78	82	82	82	80	80	84	84	84	84	84
Dimensions - unit with option 150														
Length		mm	3059	3059	3290	3290	3290	4730	4730	4730	4730	4832	4832	4832
Width		mm	936	936	1105	1105	1105	1039	1039	1202	1202	2174	2174	2174
Height		mm	1743	1743	1970	1970	1970	1997	1997	2071	2071	1585	1585	1585
Operating weight ⁽⁴⁾		kg	2981	3020	4072	4117	4145	6872	6950	7721	8059	11225	11279	11279
Compressors														
Semi-hermetic 06T screw compressors, 50 r/s														
Circuit A	-		1	1	1	1	1	1	1	1	1	1	1	1
Circuit B	-		-	-	-	-	-	1	1	1	1	1	1	1

* In accordance with standard EN14511-3:2013.

** In accordance with standard EN14825:2013, average climate

HW1 Heating mode conditions: Evaporator entering/leaving water temperature 10°C/7°C, condenser entering/leaving water temperature 30°C/35°C, evaporator and condenser fouling factor 0 m². k/W

HW2 Heating mode conditions: Evaporator entering/leaving water temperature 10°C/7°C, condenser entering/leaving water temperature 40°C/45°C, evaporator and condenser fouling factor 0 m². k/W

HW3 Heating mode conditions: Evaporator entering/leaving water temperature 10°C/7°C, condenser entering/leaving water temperature 47°C/55°C, evaporator and condenser fouling factor 0 m². k/W

CW1 Cooling mode conditions: Evaporator water entering/leaving temperature 12°C/7°C, condenser entering/leaving water temperature 30°C/35°C, evaporator and condenser fouling factor 0 m².K/W

η_s heat_{30/35°C} & SCOP_{30/35°C} Applicable Ecodesign regulation: (EU) No 813/2013

η_s heat_{47/55°C} & SCOP_{47/55°C} Applicable Ecodesign regulation: (EU) No 813/2013

η_s cool_{12/7°C} & SEER_{12/7°C} **Applicable Ecodesign regulation: (EU) No 2016/2281**

SEPR_{12/7°C} **Applicable Ecodesign regulation: (EU) No 2016/2281**

IPLV.SI Calculations according to standard performances AHRI 551-591.

(1) In dB ref=10⁻¹² W, (A) weighting. Declared dualnumber noise emission values in accordance with ISO 4871 (with an associated uncertainty of +/-3dB(A)). Measured in accordance with ISO 9614-1 and certified by Eurovent.

(2) In dB ref 20μPa, (A) weighting. Declared dualnumber noise emission values in accordance with ISO 4871 (with an associated uncertainty of +/-3dB(A)). For information, calculated from the sound power level Lw(A).

(3) Option 257 = Low noise level

(4) Weight shown is guideline only. Please refer to the unit nameplate



Eurovent certified values



AHRI certified values
30XW-only

PHYSICAL DATA, UNITS FOR HIGH CONDENSING TEMPERATURES

Standard-efficiency units (option 150)

30XW-P / 30XWHP		512	562	712	812	862	1012	1162	1314	1464	1612	1762
Refrigerant ⁽⁴⁾		R-134a										
Circuit A	kg	130	130	180	175	170	120	120	130	130	240	250
	teqCO ₂	186	186	257	250	243	172	172	186	186	343	358
Circuit B	kg	-	-	-	-	-	120	120	150	130	240	250
	teqCO ₂	-	-	-	-	-	172	172	215	186	343	358
Oil - unit with option 150		SW220										
Circuit A	l	32	32	0	36	36	32	32	36	36	36	36
Circuit B	l	-	-	-	-	-	32	32	32	36	36	36
Capacity control		Touch Pilot, electronic expansion valves (EXV)										
Minimum capacity ⁽⁵⁾	%	30	30	15	15	15	15	15	10	10	10	10
Evaporator		Multi-pipe flooded type										
Water volume	l	101	101	154	154	154	293	293	321	321	473	473
Water connections (Victaulic)	in	6	6	8	8	8	8	8	8	8	10	10
Drain and vent connections (NPT)	in	3/8	3/8	3/8	3/8	3/8	3/8	3/8	3/8	3/8	3/8	3/8
Max. water-side operating pressure	kPa	1000	1000	1000	1000	1000	1000	1000	1000	1000	1000	1000
Condenser		Multi-pipe flooded type										
Water volume	l	103	103	148	148	148	316	316	340	340	623	623
Water connections (Victaulic)	in	6	6	8	8	8	8	8	10	10	10	10
Drain and vent connections (NPT)	in	3/8	3/8	3/8	3/8	3/8	3/8	3/8	3/8	3/8	3/8	3/8
Max. water-side operating pressure	kPa	1000	1000	1000	1000	1000	1000	1000	1000	1000	1000	1000

(4) Weight shown is guideline only. Please refer to the unit nameplate

(5) Minimum unit capacity corresponds to a physical state of the unit and is given for indication only. The actual capacity at this stage depends on operating conditions.

ELECTRICAL DATA, UNITS FOR HIGH CONDENSING TEMPERATURES

Standard-efficiency units (option 150)

30XW--/30XWH-		254	304	354	402	452	552	602	652	702	802
Power circuit											
Nominal power supply	V-ph-Hz	400-3-50									
Voltage range	V	360-440									
Control circuit											
24 V via the built-in transformer											
Nominal start-up current*											
Circuit A	A	303	388	388	587	587	587	587	772	772	772
Circuit B	A	-	-	-	-	-	-	-	-	-	-
Option 81	A	-	-	-	-	-	-	-	-	-	-
Maximum start-up current**											
Circuit A	A	303	388	388	587	587	587	587	772	772	772
Circuit B	A	-	-	-	-	-	-	-	-	-	-
Option 81	A	-	-	-	-	-	-	-	-	-	-
Cosine phi											
Nominal***		0.79	0.78	0.79	0.83	0.85	0.85	0.85	0.84	0.86	0.87
Maximum****		0.88	0.87	0.88	0.90	0.90	0.91	0.91	0.90	0.90	0.90
Total harmonic distortion****	%	0	0	0	0	0	0	0	0	0	0
Maximum power input†											
Circuit A	kW	97	111	122	156	173	191	191	249	268	286
Circuit B	kW	-	-	-	-	-	-	-	-	-	-
Option 81	kW	-	-	-	-	-	-	-	-	-	-
Nominal current drawn***											
Circuit A	A	95	109	125	150	162	171	171	193	214	232
Circuit B	A	-	-	-	-	-	-	-	-	-	-
Option 81	A	-	-	-	-	-	-	-	-	-	-
Maximum current drawn (Un)†											
Circuit A	A	160	185	200	250	275	300	300	400	430	460
Circuit B	A	-	-	-	-	-	-	-	-	-	-
Option 81	A	-	-	-	-	-	-	-	-	-	-
Maximum current drawn (Un -10%)****											
Circuit A	A	176	206	224	270	300	330	330	419	455	476
Circuit B	A	-	-	-	-	-	-	-	-	-	-
Option 81	A	-	-	-	-	-	-	-	-	-	-

* Instantaneous start-up current (maximum operating current of the smallest compressor(s) + locked rotor current or reduced start-up current of the largest compressor). Values based on standard Eurovent unit operating conditions: evaporator entering/leaving water temp. = 12°C/7°C, condenser entering/leaving water temp. = 30°C/35°C.

** Instantaneous start-up current (maximum operating current of the smallest compressor(s) + locked rotor current or reduced start-up current of the largest compressor). Values obtained at operation with maximum unit power input.

*** Values based on standard Eurovent unit operating conditions: evaporator entering/leaving water temp. = 12°C/7°C, condenser entering/leaving water temp. = 30°C/35°C.

**** Values obtained at operation with maximum unit power input.

† Values obtained at operation with maximum unit power input. Values given on the unit name plate.

ELECTRICAL DATA, UNITS FOR HIGH CONDENSING TEMPERATURES

Standard-efficiency units (option 150)

30XW--/30XWH-		852	1002	1052	1154	1252	1352	1452	1552	1652	1702
Power circuit											
Nominal power supply	V-ph-Hz	400-3-50									
Voltage range	V	360-440									
Control circuit											
24 V via the built-in transformer											
Nominal start-up current*											
Circuit A	A	772	587	587	587	772	772	772	772	772	772
Circuit B	A	-	587	587	587	587	772	772	772	772	772
Option 81	A	-	757	757	757	943	965	986	1004	1004	1004
Maximum start-up current**											
Circuit A	A	772	587	587	587	772	772	772	772	772	772
Circuit B	A	-	587	587	587	587	772	772	772	772	772
Option 81	A	-	887	887	887	1072	1172	1202	1232	1004	1232
Cosine phi											
Nominal***		0.87	0.85	0.85	0.85	0.86	0.85	0.86	0.87	0.86	0.87
Maximum****		0.90	0.90	0.91	0.91	0.91	0.91	0.91	0.91	0.91	0.91
Total harmonic distortion****	%	0	0	0	0	0	0	0	0	0	0
Maximum power input†											
Circuit A	kW	286	191	191	191	252	252	271	290	290	290
Circuit B	kW	-	173	191	191	191	252	271	290	271	290
Option 81	kW	-	364	382	382	443	504	542	580	562	580
Nominal current drawn***											
Circuit A	A	232	171	171	171	210	210	230	250	250	250
Circuit B	A	-	162	171	171	171	210	230	250	230	250
Option 81	A	-	333	342	342	381	420	460	500	480	500
Maximum current drawn (Un)†											
Circuit A	A	460	300	300	300	400	400	430	460	460	460
Circuit B	A	-	275	300	300	300	400	430	460	430	460
Option 81	A	-	575	600	600	700	800	860	920	890	920
Maximum current drawn (Un -10%)****											
Circuit A	A	476	330	330	330	419	419	455	476	476	476
Circuit B	A	-	300	330	330	330	419	455	476	455	476
Option 81	A	-	630	660	660	749	838	910	952	931	952

* Instantaneous start-up current (maximum operating current of the smallest compressor(s) + locked rotor current or reduced start-up current of the largest compressor). Values based on standard Eurovent unit operating conditions: evaporator entering/leaving water temp. = 12°C/7°C, condenser entering/leaving water temp. = 30°C/35°C.

** Instantaneous start-up current (maximum operating current of the smallest compressor(s) + locked rotor current or reduced start-up current of the largest compressor). Values obtained at operation with maximum unit power input.

*** Values based on standard Eurovent unit operating conditions: evaporator entering/leaving water temp. = 12°C/7°C, condenser entering/leaving water temp. = 30°C/35°C.

**** Values obtained at operation with maximum unit power input.

† Values obtained at operation with maximum unit power input. Values given on the unit name plate.

ELECTRICAL DATA, UNITS FOR HIGH CONDENSING TEMPERATURES

High-efficiency units (option 150)

30XW-P/30XWHP		512	562	712	812	862	1012	1162	1314	1464	1612	1762
Power circuit												
Nominal power supply	V-ph-Hz	400-3-50										
Voltage range	V	360-440										
Control circuit												
24 V via the built-in transformer												
Nominal start-up current*												
Circuit A	A	587	587	772	772	772	587	587	772	772	772	772
Circuit B	A	-	-	-	-	-	587	587	587	772	772	772
Option 81	A	-	-	-	-	-	749	757	943	965	986	1004
Maximum start-up current**												
Circuit A	A	587	587	772	772	772	587	587	772	772	772	772
Circuit B	A	-	-	-	-	-	587	587	587	772	772	772
Option 81	A	-	-	-	-	-	862	887	1072	1172	1202	1232
Cosine phi												
Nominal***		0.88	0.88	0.84	0.86	0.87	0.87	0.88	0.86	0.85	0.86	0.87
Maximum****		0.91	0.92	0.90	0.90	0.90	0.91	0.92	0.91	0.91	0.91	0.91
Total harmonic distortion****	%	0	0	0	0	0	0	0	0	0	0	0
Maximum power input†												
Circuit A	kW	173	191	252	271	290	173	191	252	252	271	290
Circuit B	kW	-	-	-	-	-	173	191	191	252	271	290
Option 81	kW	-	-	-	-	-	346	382	443	504	542	580
Nominal current drawn***												
Circuit A	A	162	171	210	230	250	162	171	210	210	230	250
Circuit B	A	-	-	-	-	-	162	171	171	210	230	250
Option 81	A	-	-	-	-	-	324	342	381	420	460	500
Maximum current drawn (Un)†												
Circuit A	A	275	300	400	430	460	275	300	400	400	430	460
Circuit B	A	-	-	-	-	-	275	300	300	400	430	460
Option 81	A	-	-	-	-	-	550	600	700	800	860	920
Maximum current drawn (Un -10%)****												
Circuit A	A	300	330	419	455	476	300	330	419	419	455	476
Circuit B	A	-	-	-	-	-	300	330	330	419	455	476
Option 81	A	-	-	-	-	-	600	660	749	838	910	952

* Instantaneous start-up current (maximum operating current of the smallest compressor(s) + locked rotor current or reduced start-up current of the largest compressor). Values based on standard Eurovent unit operating conditions: evaporator entering/leaving water temp. = 12°C/7°C, condenser entering/leaving water temp. = 30°C/35°C.

** Instantaneous start-up current (maximum operating current of the smallest compressor(s) + locked rotor current or reduced start-up current of the largest compressor). Values obtained at operation with maximum unit power input.

*** Values based on standard Eurovent unit operating conditions: evaporator entering/leaving water temp. = 12°C/7°C, condenser entering/leaving water temp. = 30°C/35°C.

**** Values obtained at operation with maximum unit power input.

† Values obtained at operation with maximum unit power input. Values given on the unit name plate.

PHYSICAL DATA, LOW-TEMPERATURE UNITS

Standard and high-efficiency 30XW--/30XWP units (options 5 and 6)

30XW- / 30XWP			P0512	P0562	P1012	-1154	
Unit + option 5 Full load performances*	CW3	Nominal capacity	kW	304	336	623	689
		EER	kW/kW	3,43	3,43	3,42	3,38
Unit + option 6 Full load performances*	CW4	Nominal capacity	kW	471	518	969	597
		EER	kW/kW	4,64	4,58	4,71	3,11
Seasonal energy efficiency	SEPR -2/-8°C Process medium temp.		kWh/kWh	3.87	3.84	3.87	3.82
	SEPR 12/7°C Process high temp.		kWh/kWh	6.11	6.02	6.20	5.97
	SEER 12/7°C Comfort low temp.		kWh/kWh	5.67	5.63	5.89	5.86

* In accordance with standard EN14511-3:2013.

CW3 Cooling mode conditions: Evaporator water entering/leaving temperature 0°C/-5°C, condenser entering/leaving water temperature 30°C/35°C, evaporator and condenser fouling factor 0 m².K/W

CW4 Cooling mode conditions: Evaporator water entering/leaving temperature -2°C/-8°C, condenser entering/leaving water temperature 30°C/35°C, evaporator and condenser fouling factor 0 m².K/W

SEPR _{-2/-8°C}
SEER _{12/7°C} & **SEPR** _{12/7°C} **Applicable Ecodesign regulation: (EU) No 2015/1095**
 Applicable Ecodesign regulation: (EU) No 2016/2281

ELECTRICAL DATA, LOW-TEMPERATURE UNITS

Standard and high-efficiency 30XW--/30XWP units (options 5 and 6)

Reference number	Options 5 and 6				
	P0512	P0562	P1012	-1154	
Power circuit					
Nominal power supply	V-ph-Hz	400-3-50			
Voltage range	V	360-440			
Control circuit					
24 V via the built-in transformer					
Nominal start-up current*					
Circuits A/B	A	587/-	587/-	587/587	587/587
Option 81	A	-	-	749	757
Maximum start-up current**					
Circuits A/B	A	587/-	587/-	587/587	587/587
Option 81	A	-	-	862	887
Cosine phi					
Nominal***		0.88	0.88	0.87	0.85
Maximum****		0.91	0.92	0.91	0.91
Total harmonic distortion ****	%	0	0	0	0
Maximum power input†					
Circuits A/B	kW	173/-	191/-	173/173	191/191
Option 81	kW	-	-	346	382
Nominal current drawn***					
Circuits A/B	A	162/-	171/-	162/162	171/171
Option 81	A	-	-	324	342
Maximum current drawn (Un)†					
Circuits A/B	A	275/-	300/-	275/275	300/300
Option 81	A	-	-	550	600
Maximum current drawn (Un -10%)****					
Circuits A/B	A	300/-	330/-	300/300	330/330
Option 81	A	-	-	600	660

- * Instantaneous start-up current (maximum operating current of the smallest compressor(s) + locked rotor current or reduced start-up current of the largest compressor). Values obtained at standard Eurovent unit operating conditions: evaporator entering/leaving water temperature = 12°C/7°C, condenser entering/leaving water temperature = 30°C/35°C.
- ** Instantaneous start-up current (maximum operating current of the smallest compressor(s) + locked rotor current or reduced start-up current of the largest compressor). Values obtained at operation with maximum unit power input.
- *** Values obtained at standard Eurovent unit operating conditions: evaporator entering/leaving water temperature = 12°C/7°C, condenser entering/leaving water temperature = 30°C/35°C. Maximum values obtained at operation with maximum unit power input.
- **** Values obtained at operation with maximum unit power input.
- † Values obtained at operation with maximum unit power input. Values given on the unit name plate.

Notes, electrical data and operating conditions 30XW

- As standard
30XW 254 to 862 units have a single power connection point located immediately upstream of the main disconnect switch.
30XW 1002 to 1762 units have two connection points located immediately upstream of the main disconnect switches.
- The control box includes the following standard features:
 - One main disconnect switch per circuit*
 - Starter and motor protection devices for each compressor
 - Anti-short cycle protection devices*
 - Control devices
- Field connections:
All connections to the system and the electrical installations must be in full accordance with all applicable codes.
- The Carrier 30XW units are designed and built to ensure conformance with local codes. The recommendations of European standard EN 60204-1 (corresponds to IEC 60204-1) (machine safety - electrical machine components - part 1: general regulations) are specifically taken into account, when designing the electrical equipment.
- The absence of power supply disconnect switch(es) and short-cycle protection devices in option 82A is an important factor that has to be taken into consideration at the installation site.
Units equipped with one of these two options are supplied with a declaration of incorporation, as required by the machinery directive.

NOTES:

- Generally the recommendations of IEC 60364 are accepted as compliance with the requirements of the installation directives. Conformance with EN 60204-1 is the best means of ensuring compliance with the Machines Directive.
- Annex B of EN 60204 1 describes the electrical characteristics used for the operation of the machines.

1. The operating environment for the 30XW units is specified below:
 - Environment** Environment as classified in EN 60721 (corresponds to IEC 60721):
 - indoor installation
 - ambient temperature range: minimum temperature +5°C to +42°C, class AA4
 - altitude: lower than or equal to 2000 m
 - presence of water: class AD2 (possibility of water droplets)
 - presence of hard solids, class 4S2 (no significant dust present)
 - presence of corrosive and polluting substances, class 4C2 (negligible)
2. The neutral (N) line must not be connected directly to the unit (if necessary use a transformer).
3. The neutral (N) line must not be connected directly to the unit (if necessary use a transformer).
4. Overcurrent protection of the power supply conductors is not provided with the unit.
5. The factory installed disconnect switch(es)/circuit breaker(s) is (are) of a type suitable for power interruption in accordance with EN 60947-3 (corresponds to IEC 60947-3).
6. The units are designed for connection to TN networks (IEC 60364). For IT networks the earth connection must not be at the network earth. Provide a local earth, consult competent local organisations to complete the electrical installation.

NOTE: If particular aspects of an actual installation do not conform to the conditions described above, or if there are other conditions which should be considered, always contact your local Carrier representative.

* Not provided for units equipped with option 82A

** The required protection level for this class is IP21B or 1PX1B (according to reference document IEC 60529). All 30XW units fulfil this protection condition. In general the casings fulfil class IP23 or IPX3B.-

PART LOAD PERFORMANCES

With the rapid increase in energy costs and the care about environmental impacts of electricity production, power consumption of air conditioning equipment has become an important topic. The energy efficiency of a unit at full load is rarely representative of the actual performance of the units, as on average a unit works less than 5% of the time at full load.

IPLV (in accordance with AHRI 550/590)

The IPLV (integrated part load value) allows evaluation of the average energy efficiency based on four operating conditions defined by the AHRI (Air Conditioning, Heating and Refrigeration Institute). The IPLV is the average weighted value of the cooling coefficient of performance (COPR) at different operating conditions, weighted by the operating time.

IPLV (integrated part load value)

Load %	Condenser entering water temperature, °C	Energy efficiency	Operating time, %
100	29.4	COPR ₁	1
75	23.9	COPR ₂	42
50	18.3	COPR ₃	45
25	18.3	COPR ₄	12

$$\text{IPLV} = \text{COPR}_1 \times 1\% + \text{COPR}_2 \times 42\% + \text{COPR}_3 \times 45\% + \text{COPR}_4 \times 12\%$$

Note: Constant leaving water temperature 6.67°C (44°F).
Condenser fouling factor: 0.44×10^{-4} (m² K)/W, evaporator fouling factor: 0.18×10^{-4} (m² K)/W.

The heat load of a building depends on many factors, such as the outside air temperature, the exposure to the sun and its occupation.

Consequently it is preferable to use the average energy efficiency, calculated at several operating points that are representative for the unit utilisation.

SEER for comfort chillers (in accordance with EU ECODESIGN)

The **SEER (Seasonal Energy Efficiency Ratio)** measures the seasonal energy efficiency of comfort **chillers** by calculating the ratio between annual cooling demand of the building and annual energy demand of the chiller. It takes into account the energy efficiency achieved for each outdoor temperature weighted by the number of hours observed for each of these temperatures, using actual climate data.

SEER is a new way of measuring the true energy efficiency of chillers for **comfort cooling** over an entire year.

This new indicator gives a more realistic indication of the real energy efficiency and environmental impact of a cooling system (Ecodesign Regulation 2016/2281).

SCOP (In accordance with EU ECODESIGN)

The SCOP (Seasonal Coefficient of Performance) permit evaluation of the average energy efficiency at part load, based on multipoint conditions (16°C to -10°C for average climate) and number of hours occurring at each air temperature (Bin hours).

To be able to compare the energy efficiency of boilers using a primary energy source (gas or fuel) with heat pumps using a final energy source (electricity), the seasonal efficiency criteria used by the Ecodesign regulations is known as η_s it is based on the use of primary energy sources and expressed in %.

The heat load of a building depends on many factors, such as the outside air temperature, the exposure to the sun and the building occupancy.

Consequently it is preferable to use the average energy efficiency, calculated at several operating points that are representative for the unit utilisation.

SEPR for process chillers (in accordance with EU ECODESIGN)

The **SEPR (Seasonal Energy Performance Ratio)** measures the seasonal energy efficiency of **process chillers** by calculating the ratio between annual cooling demand of the process and annual energy demand of the chiller. It takes into account the energy efficiency achieved at each outdoor temperature of an average climate weighted by the number of hours observed for each of these temperatures.

SEPR is a new way of measuring the true energy efficiency of chillers for **process cooling** over an entire year. This new indicator gives a more realistic indication of the real energy efficiency and environmental impact of the cooling system (Ecodesign Regulation 2015/1095).

SOUND SPECTRUM

30XW units

		Octave bands, Hz						Sound power levels	
		125	250	500	1k	2k	4k		
Standard-efficiency units 30XW--/30XWH-									
254	dB	56	81	86	93	88	70	dB(A)	95
304	dB	56	81	86	93	88	70	dB(A)	95
354	dB	56	81	86	93	88	70	dB(A)	95
402	dB	76	85	94	97	87	75	dB(A)	99
452	dB	76	85	94	97	87	75	dB(A)	99
552	dB	76	85	94	97	87	75	dB(A)	99
602	dB	76	85	94	97	87	75	dB(A)	99
652	dB	72	84	94	97	89	74	dB(A)	99
702	dB	72	84	94	97	89	74	dB(A)	99
802	dB	72	84	94	97	89	74	dB(A)	99
852	dB	72	84	94	97	89	74	dB(A)	99
1002	dB	79	88	97	100	90	78	dB(A)	102
1052	dB	79	88	97	100	90	78	dB(A)	102
1154	dB	79	88	97	100	90	78	dB(A)	102
1252	dB	79	88	97	100	90	78	dB(A)	102
1352	dB	77	88	97	100	91	78	dB(A)	102
1452	dB	75	87	97	100	92	77	dB(A)	102
1552	dB	75	87	97	100	92	77	dB(A)	102
1652	dB	75	87	97	100	92	77	dB(A)	102
1702	dB	75	87	97	100	92	77	dB(A)	102
High-efficiency units 30XW-P/30XWHP									
512	dB	76	85	94	97	87	75	dB(A)	99
562	dB	76	85	94	97	87	75	dB(A)	99
712	dB	72	84	94	97	89	74	dB(A)	99
812	dB	72	84	94	97	89	74	dB(A)	99
862	dB	72	84	94	97	89	74	dB(A)	99
1012	dB	79	88	97	100	90	78	dB(A)	102
1162	dB	79	88	97	100	90	78	dB(A)	102
1314	dB	77	88	97	100	91	78	dB(A)	102
1464	dB	75	87	97	100	92	77	dB(A)	102
1612	dB	75	87	97	100	92	77	dB(A)	102
1762	dB	75	87	97	100	92	77	dB(A)	102

30XW units with option 257*

		Octave bands, Hz						Sound power levels	
		125	250	500	1k	2k	4k		
Standard-efficiency units 30XW--/30XWH-									
254	dB	-	-	-	-	-	-	dB(A)	-
304	dB	-	-	-	-	-	-	dB(A)	-
354	dB	-	-	-	-	-	-	dB(A)	-
402	dB	76	85	90	93	85	75	dB(A)	96
452	dB	76	85	90	93	85	75	dB(A)	96
552	dB	76	85	90	93	85	75	dB(A)	96
602	dB	76	85	90	93	85	75	dB(A)	96
652	dB	72	84	90	93	87	74	dB(A)	96
702	dB	72	84	90	93	87	74	dB(A)	96
802	dB	72	84	90	93	87	74	dB(A)	96
852	dB	72	84	90	93	87	74	dB(A)	96
1002	dB	79	88	93	96	88	78	dB(A)	99
1052	dB	79	88	93	96	88	78	dB(A)	99
1154	dB	79	88	93	96	88	78	dB(A)	99
1252	dB	79	88	93	96	88	78	dB(A)	99
1352	dB	77	87	93	96	89	77	dB(A)	99
1452	dB	77	87	93	96	89	77	dB(A)	99
1552	dB	77	87	93	96	89	77	dB(A)	99
1652	dB	77	87	93	96	89	77	dB(A)	99
1702	dB	77	87	93	96	89	77	dB(A)	99
High-efficiency units 30XW-P/30XWHP									
512	dB	76	85	90	93	85	75	dB(A)	96
562	dB	76	85	90	93	85	75	dB(A)	96
712	dB	72	84	90	93	87	74	dB(A)	96
812	dB	72	84	90	93	87	74	dB(A)	96
862	dB	72	84	90	93	87	74	dB(A)	96
1012	dB	79	88	93	96	88	78	dB(A)	99
1162	dB	79	88	93	96	88	78	dB(A)	99
1314	dB	77	87	93	96	89	77	dB(A)	99
1464	dB	77	87	93	96	89	77	dB(A)	99
1612	dB	77	87	93	96	89	77	dB(A)	99
1762	dB	77	87	93	96	89	77	dB(A)	99

* Option 257 = Low sound level

Note: The sound levels by octave bands are given for information only and not contractually binding. Only the global sound level is contractually binding.

SOUND SPECTRUM

30XW units with high condensing temperature (option 150)

		Octave bands, Hz						Sound power levels	
		125	250	500	1k	2k	4k		
Standard-efficiency units 30XW--/30XWH- (option 150)									
254	dB	55	80	89	92	88	77	dB(A)	95
304	dB	55	80	89	92	88	77	dB(A)	95
354	dB	55	80	89	92	88	77	dB(A)	95
402	dB	76	85	94	97	87	75	dB(A)	99
452	dB	76	85	94	97	87	75	dB(A)	99
552	dB	76	85	94	97	87	75	dB(A)	99
602	dB	76	85	94	97	87	75	dB(A)	99
652	dB	69	89	97	99	92	77	dB(A)	102
702	dB	69	89	97	99	92	77	dB(A)	102
802	dB	69	89	97	99	92	77	dB(A)	102
852	dB	69	89	97	99	92	77	dB(A)	102
1002	dB	79	88	97	100	90	78	dB(A)	102
1052	dB	79	88	97	100	90	78	dB(A)	102
1154	dB	79	88	97	100	90	78	dB(A)	102
1252	dB	79	88	97	100	90	78	dB(A)	102
1352	dB	74	92	100	102	95	79	dB(A)	105
1452	dB	74	92	100	102	95	79	dB(A)	105
1552	dB	74	92	100	102	95	79	dB(A)	105
1652	dB	74	92	100	102	95	79	dB(A)	105
1702	dB	74	92	100	102	95	79	dB(A)	105
High-efficiency units 30XW-P/30XWHP (option 150)									
512	dB	76	85	94	97	87	75	dB(A)	99
562	dB	76	85	94	97	87	75	dB(A)	99
712	dB	69	89	97	99	92	77	dB(A)	102
812	dB	69	89	97	99	92	77	dB(A)	102
862	dB	69	89	97	99	92	77	dB(A)	102
1012	dB	79	88	97	100	90	78	dB(A)	102
1162	dB	79	88	97	100	90	78	dB(A)	102
1314	dB	74	92	100	102	95	79	dB(A)	105
1464	dB	74	92	100	102	95	79	dB(A)	105
1612	dB	74	92	100	102	95	79	dB(A)	105
1762	dB	74	92	100	102	95	79	dB(A)	105

30XW units with high condensing temperature (opt. 150)* and opt. 257*

		Octave bands, Hz						Sound power levels	
		125	250	500	1k	2k	4k		
Standard-efficiency units 30XW--/30XWH- (option 150)									
254	dB	-	-	-	-	-	-	dB(A)	-
304	dB	-	-	-	-	-	-	dB(A)	-
354	dB	-	-	-	-	-	-	dB(A)	-
402	dB	76	85	90	93	85	75	dB(A)	96
452	dB	76	85	90	93	85	75	dB(A)	96
552	dB	76	85	90	93	85	75	dB(A)	96
602	dB	76	85	90	93	85	75	dB(A)	96
652	dB	69	89	93	98	91	76	dB(A)	100
702	dB	69	89	93	98	91	76	dB(A)	100
802	dB	69	89	93	98	91	76	dB(A)	100
852	dB	69	89	93	98	91	76	dB(A)	100
1002	dB	79	88	93	96	88	78	dB(A)	99
1052	dB	79	88	93	96	88	78	dB(A)	99
1154	dB	79	88	93	96	88	78	dB(A)	99
1252	dB	79	88	93	96	88	78	dB(A)	99
1352	dB	74	92	96	101	94	78	dB(A)	103
1452	dB	74	92	96	101	94	78	dB(A)	103
1552	dB	74	92	96	101	94	78	dB(A)	103
1652	dB	74	92	96	101	94	78	dB(A)	103
1702	dB	74	92	96	101	94	78	dB(A)	103
High-efficiency units 30XW-P/30XWHP (option 150)									
512	dB	76	85	90	93	85	75	dB(A)	96
562	dB	76	85	90	93	85	75	dB(A)	96
712	dB	69	89	93	98	91	76	dB(A)	100
812	dB	69	89	93	98	91	76	dB(A)	100
862	dB	69	89	93	98	91	76	dB(A)	100
1012	dB	79	88	93	96	88	78	dB(A)	99
1162	dB	79	88	93	96	88	78	dB(A)	99
1314	dB	74	92	96	101	94	78	dB(A)	103
1464	dB	74	92	96	101	94	78	dB(A)	103
1612	dB	74	92	96	101	94	78	dB(A)	103
1762	dB	74	92	96	101	94	78	dB(A)	103

SOUND SPECTRUM

30XW with “Very low sound level” accessory

		Octave bands, Hz						Sound power levels	
		125	250	500	1k	2k	4k		
Standard-efficiency units 30XW--/30XWH-									
254	dB	51	64	67	72	68	57	dB(A)	75
304	dB	51	64	67	72	68	57	dB(A)	75
354	dB	51	64	67	72	68	57	dB(A)	75
402	dB	71	68	75	74	65	61	dB(A)	79
452	dB	71	68	75	74	65	61	dB(A)	79
552	dB	71	68	75	74	65	61	dB(A)	79
602	dB	71	68	75	74	65	61	dB(A)	79
652	dB	67	67	75	74	67	60	dB(A)	79
702	dB	67	67	75	74	67	60	dB(A)	79
802	dB	67	67	75	74	67	60	dB(A)	79
852	dB	67	67	75	74	67	60	dB(A)	79
1002	dB	70	72	78	79	67	60	dB(A)	82
1052	dB	70	72	78	79	67	60	dB(A)	82
1154	dB	70	72	78	79	67	60	dB(A)	82
1252	dB	70	72	78	79	67	60	dB(A)	82
1352	dB	68	72	78	79	68	60	dB(A)	82
1452	dB	66	71	78	79	69	59	dB(A)	82
1552	dB	66	71	78	79	69	59	dB(A)	82
1652	dB	66	71	78	79	69	59	dB(A)	82
1702	dB	-	-	-	-	-	-	dB(A)	-
High-efficiency units 30XW-P/30XWHP									
512	dB	71	68	75	74	65	61	dB(A)	79
562	dB	71	68	75	74	65	61	dB(A)	79
712	dB	67	67	75	74	67	60	dB(A)	79
812	dB	67	67	75	74	67	60	dB(A)	79
862	dB	67	67	75	74	67	60	dB(A)	79
1012	dB	70	72	78	79	67	60	dB(A)	82
1162	dB	70	72	78	79	67	60	dB(A)	82
1314	dB	68	72	78	79	68	60	dB(A)	82
1464	dB	66	71	78	79	69	59	dB(A)	82
1612	dB	-	-	-	-	-	-	dB(A)	-
1762	dB	-	-	-	-	-	-	dB(A)	-

Note: The sound levels by octave bands are given for information only and not contractually binding. Only the global sound level is contractually binding.

30XW unit with high condensing temperature (option 150) and “Very low sound level” accessory

		Octave bands, Hz						Sound power levels	
		125	250	500	1k	2k	4k		
Standard-efficiency units 30XW--/30XWH- (option 150)									
254	dB	50	64	70	71	68	64	dB(A)	75
304	dB	50	64	70	71	68	64	dB(A)	75
354	dB	50	64	70	71	68	64	dB(A)	75
402	dB	71	68	75	74	65	61	dB(A)	79
452	dB	71	68	75	74	65	61	dB(A)	79
552	dB	71	68	75	74	65	61	dB(A)	79
602	dB	71	68	75	74	65	61	dB(A)	79
652	dB	64	72	78	78	72	64	dB(A)	82
702	dB	64	72	78	78	72	64	dB(A)	82
802	dB	64	72	78	78	72	64	dB(A)	82
852	dB	64	72	78	78	72	64	dB(A)	82
1002	dB	74	71	78	77	68	64	dB(A)	82
1052	dB	74	71	78	77	68	64	dB(A)	82
1154	dB	74	71	78	77	68	64	dB(A)	82
1252	dB	74	71	78	77	68	64	dB(A)	82
1352	dB	65	76	81	81	72	61	dB(A)	85
1452	dB	65	76	81	81	72	61	dB(A)	85
1552	dB	65	76	81	81	72	61	dB(A)	85
1652	dB	65	76	81	81	72	61	dB(A)	85
1702	dB	-	-	-	-	-	-	dB(A)	-
High-efficiency units 30XW-P/30XWHP (option 150)									
512	dB	71	68	75	74	65	61	dB(A)	79
562	dB	71	68	75	74	65	61	dB(A)	79
712	dB	64	72	78	78	72	64	dB(A)	82
812	dB	64	72	78	78	72	64	dB(A)	82
862	dB	64	72	78	78	72	64	dB(A)	82
1012	dB	74	71	78	77	68	64	dB(A)	82
1162	dB	74	71	78	77	68	64	dB(A)	82
1314	dB	65	76	81	81	72	61	dB(A)	85
1464	dB	65	76	81	81	72	61	dB(A)	85
1612	dB	-	-	-	-	-	-	dB(A)	-
1762	dB	-	-	-	-	-	-	dB(A)	-

OPERATING LIMITS AND OPERATING RANGES

Standard 30XW-- and 30XW-P units	Minimum	Maximum
Evaporator		
Entering temperature at start-up	-	35.0°C
Leaving temperature during operation	3.3°C*	20.0°C
Entering/leaving temperature difference at full load	2.8 K	11.1 K
Condenser		
Entering temperature at start-up	13.0°C**	-
Leaving temperature during operation	19.0°C**	50.0°C***
Entering/leaving temperature difference at full load	2.8 K	11.1 K

- * For low-temperature applications, where the leaving water temperature is below 3.3°C, a frost protection solution must be used. Please refer to option 5 and option 6.
- ** For lower condenser temperatures, a water flow control valve must be used at the condenser (two or three-way valve). Please refer to option 152 to ensure the correct condensing temperature.
- *** Please refer to option 150 for applications with a high condenser leaving temperature (up to 63°C).

Units with option 150		
30XW--/30XWH-/30XW-P/30XWHP	Minimum	Maximum
Evaporator		
Entering temperature at start-up	-	35.0°C
Leaving temperature during operation	3.3°C*	15.0°C
Entering/leaving temperature difference at full load	2.8 K	11.1 K
Condenser		
Entering temperature at start-up	13.0°C**	-
Leaving temperature during operation	23.0°C**	63.0°C
Entering/leaving temperature difference at full load	2.8 K	11.1 K

- * For low-temperature applications, where the leaving water temperature is below 3.3°C, a frost protection solution must be used. Please refer to option 5 and option 6.
- ** For lower condenser temperatures, a water flow control valve must be used at the condenser (two or three-way valve). Please refer to option 152 to ensure the correct condensing temperature.

Units with options 5 and 6		
30XW-- (1154)/30XW-P (512-562-1012)	Minimum	Maximum
Evaporator		
Entering temperature at start-up	-	35.0°C
Leaving temperature during operation*		
EG 5 Option 5 with ethylene glycol	-6°C	15.0°C
PG 5 Option 5 with propylene glycol	-3°C	15.0°C
EG 6 Option 6 with ethylene glycol	-12°C	15.0°C
PG 6 Option 6 with propylene glycol	-8°C	15.0°C
Entering/leaving temp. difference at full load	2.8 K	11.1 K***
Condenser		
Entering temperature at start-up	13.0°C**	-
Leaving temperature during operation	19.0/ 23.0°C**	55.0/ 63.0°C****
Entering/leaving temp. difference at full load	2.8 K	11.1 K

- * The operating range with evaporator leaving temperatures above 3°C is permitted, but the performances are not optimised.
- ** For lower condenser temperatures, a water flow control valve must be installed at the condenser (two-way or three-way). Please refer to option 152 to ensure the correct condensing temperature.
- *** Please refer to chapter 10.5 of the installation manual for the minimum recommended evaporator glycol flow rate.
- **** Depends on the conditions at the evaporator and the load conditions.

NOTES: Ambient temperatures: During storage and transport of the 30XW units (including by container) the minimum and maximum permissible temperatures are -20°C and 72°C (and 65°C for option 200). For more precise details refer to the unit selection program.

Standard units

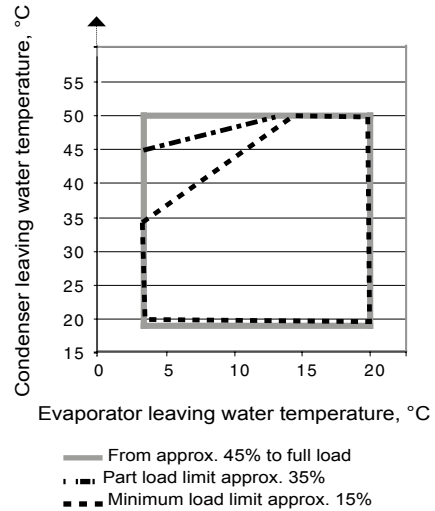

Option 150

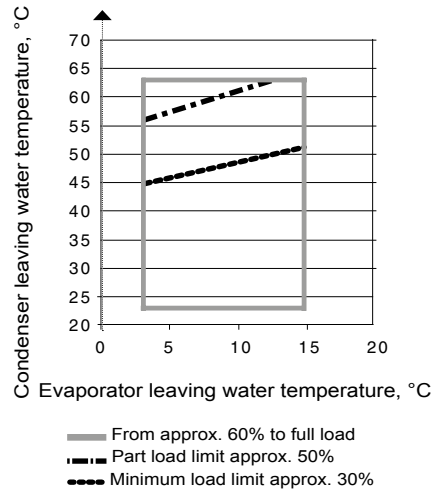

Options 5 and 6

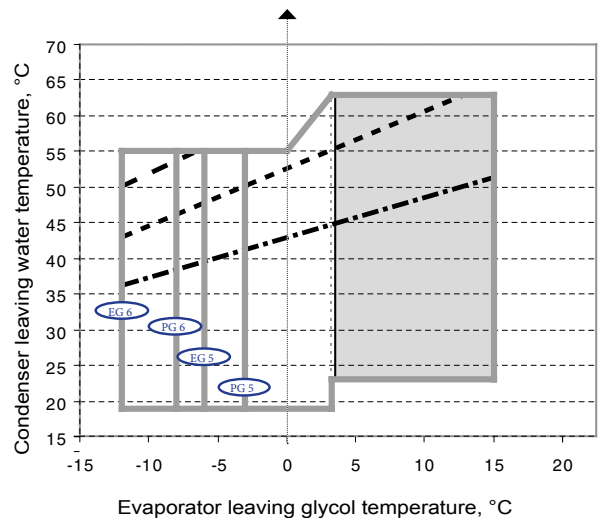

EVAPORATOR PRESSURE DROP CURVES

Units with two evaporator passes (standard):
30XW--/30XWH-/30XW-P/30XWHP

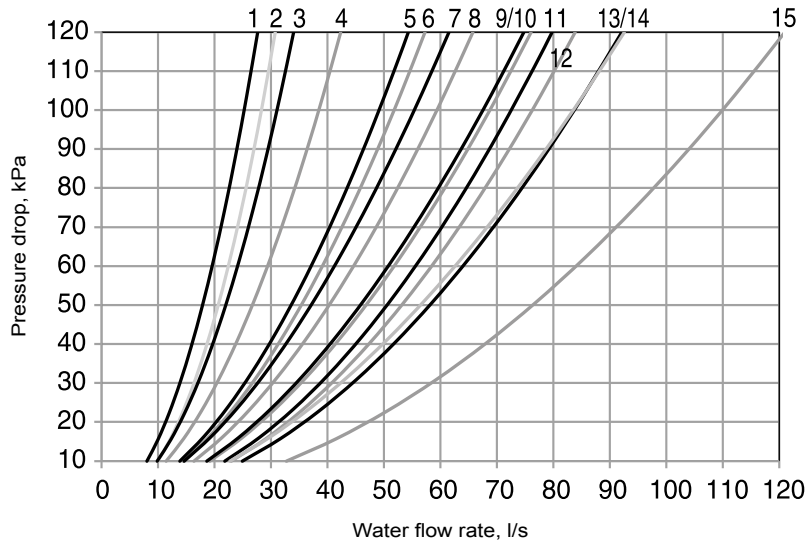

Legend

- | | |
|-----------------------|----------------------------|
| 1. 254 | 9. 1154 |
| 2. 304 | 10. 712, 812, 862 |
| 3. 354 | 11. 1012, 1162 |
| 4. 402, 452, 552, 602 | 12. 1252, 1352, 1452, 1552 |
| 5. 512, 562 | 13. 1314, 1464 |
| 6. 652, 702, 802 | 14. 1652, 1702 |
| 7. 852 | 15. 1612, 1762 |
| 8. 1002, 1052 | |

Units with one evaporator pass (option 100C):
30XW--/30XWH-/30XW-P/30XWHP

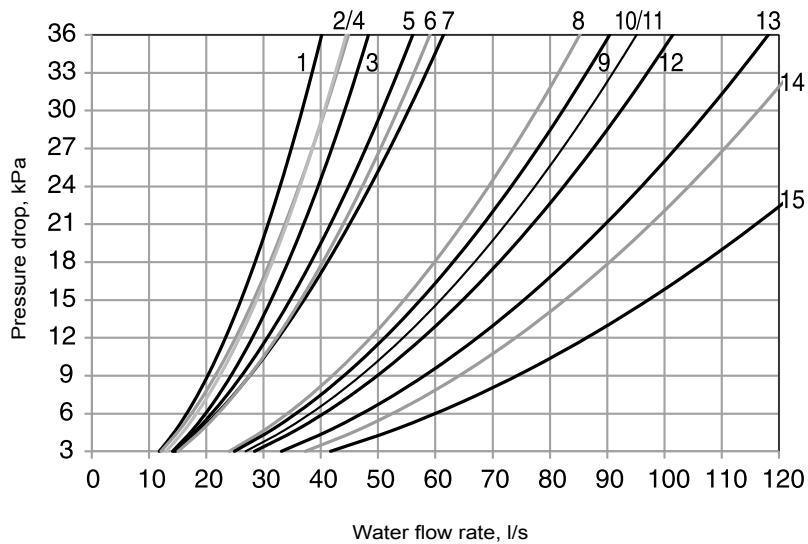

Legend

- | | |
|-----------------------|----------------------------|
| 1. 254 | 9. 1012, 1162 |
| 2. 304 | 10. 712, 812, 862 |
| 3. 354 | 11. 1252, 1352, 1452, 1552 |
| 4. 402, 452, 552, 602 | 12. 1154 |
| 5. 512, 562 | 13. 1314, 1464 |
| 6. 652, 702, 802 | 14. 1652, 1702 |
| 7. 852 | 15. 1612, 1762 |
| 8. 1002, 1052 | |

CONDENSER PRESSURE DROP CURVES

Units with two condenser passes (standard):
30XW--/30XWH-/30XW-P/30XWHP

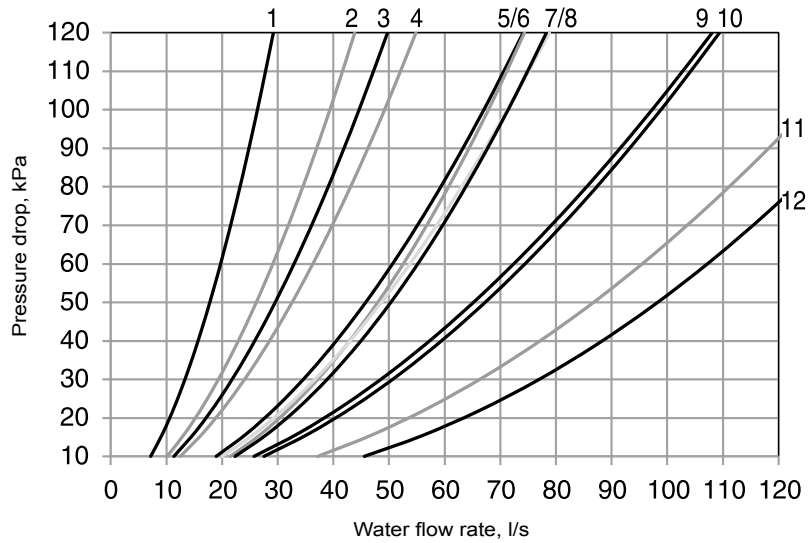

Legend

- | | |
|-----------------------|--|
| 1. 254, 304, 354 | 7. 1154 |
| 2. 402, 452, 552, 602 | 8. 1002, 1052 |
| 3. 512, 562 | 9. 1012, 1162 |
| 4. 652, 702, 802 | 10. 1252, 1352, 1452, 1552, 1314, 1464 |
| 5. 712, 812, 862 | 11. 1652, 1702 |
| 6. 852 | 12. 1612, 1762 |

Units with one condenser pass (option 102C):
30XW--/30XWH-/30XW-P/30XWHP

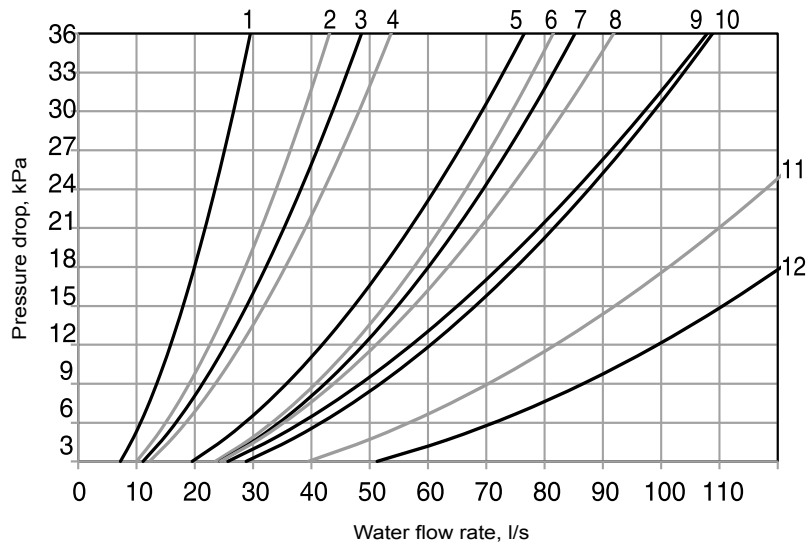

Legend

- | | |
|-----------------------|--|
| 1. 254, 304, 354 | 7. 1002, 1052 |
| 2. 402, 452, 552, 602 | 8. 1154 |
| 3. 512, 562 | 9. 1012, 1162 |
| 4. 652, 702, 802 | 10. 1252, 1352, 1452, 1552, 1314, 1464 |
| 5. 712, 812, 862 | 11. 1652, 1702 |
| 6. 852 | 12. 1612, 1762 |

DIMENSIONS/CLEARANCES

30XW--/30XWH- 254-852
30XW-P/30XWHP 512-862

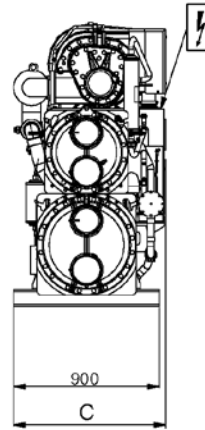
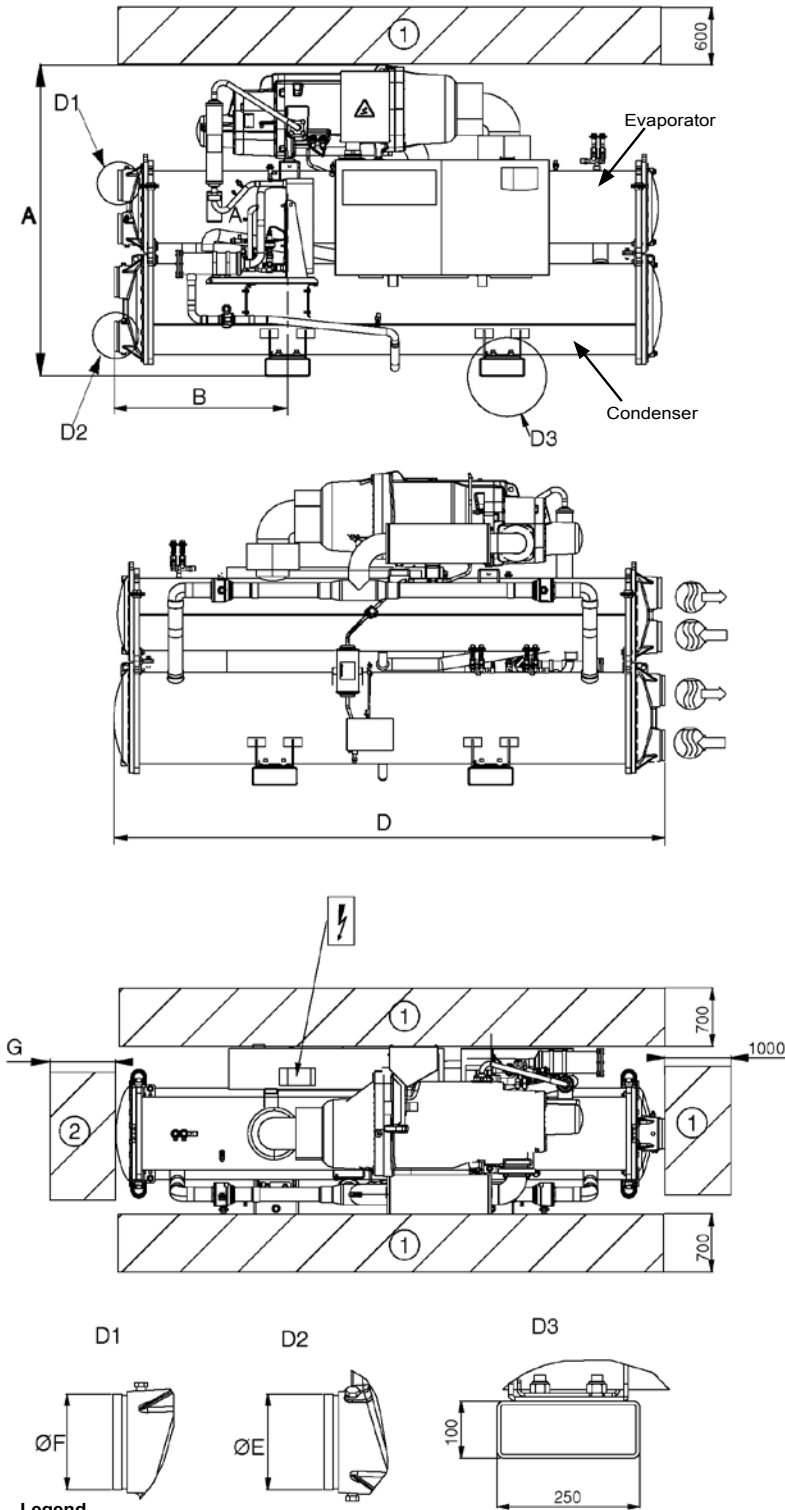

	Dimensions in mm						
	A	B	C	D	E	F	G
Standard-efficiency units 30XW--/30XWH-							
254	1567	800	928	2724	141.3	141.3	2600
304	1567	800	928	2724	141.3	141.3	2600
354	1567	800	928	2724	141.3	141.3	2600
402	1693	810	936	2742	141.3	141.3	2600
452	1693	810	936	2742	141.3	141.3	2600
552	1693	810	936	2742	141.3	141.3	2600
602	1693	810	936	2742	141.3	141.3	2600
652	1848	968	1044	3059	168.3	168.3	2800
702	1848	968	1044	3059	168.3	168.3	2800
802	1848	968	1044	3059	168.3	168.3	2800
852	1898	828	1044	2780	219.1	168.3	2600
High-efficiency units 30XW-P/30XWHP							
512	1743	968	936	3059	168.3	168.3	2800
562	1743	968	936	3059	168.3	168.3	2800
712	1950	1083	1065	3290	219.1	219.1	3100
812	1950	1083	1070	3290	219.1	219.1	3100
862	1950	1083	1070	3290	219.1	219.1	3100
Standard-efficiency units 30XW--/30XWH- (option 150)							
254	1567	800	928	2724	141.3	141.3	2600
304	1567	800	928	2724	141.3	141.3	2600
354	1567	800	928	2724	141.3	141.3	2600
402	1693	810	936	2742	141.3	141.3	2600
452	1693	810	936	2742	141.3	141.3	2600
552	1693	810	936	2742	141.3	141.3	2600
602	1693	810	936	2742	141.3	141.3	2600
652	1868	968	1090	3059	168.3	168.3	2800
702	1868	968	1090	3059	168.3	168.3	2800
802	1868	968	1090	3059	168.3	168.3	2800
852	1920	828	1090	2780	168.3	219.1	2600
High-efficiency units 30XW-P/30XWHP (option 150)							
512	1743	968	936	3059	168.3	168.3	2800
562	1743	968	936	3059	168.3	168.3	2800
712	1970	1083	1105	3290	219.1	219.1	3100
812	1970	1083	1105	3290	219.1	219.1	3100
862	1970	1083	1105	3290	219.1	219.1	3100

Legend

All dimensions are given in mm.

- ① Required clearance for maintenance
- ② Recommended clearance for tube removal
- ← Water inlet
- Water outlet
-))) Air outlet – do not obstruct
- ⚡ Power supply connection

NOTE: Drawings are not contractually binding. Before designing an installation, consult the certified dimensional drawings, available on request.

DIMENSIONS/CLEARANCES

30XW--/30XWH- 1002-1552
 30XW-P/30XWHP 1012-1464

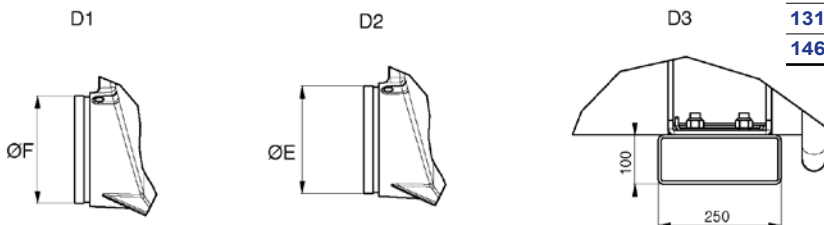
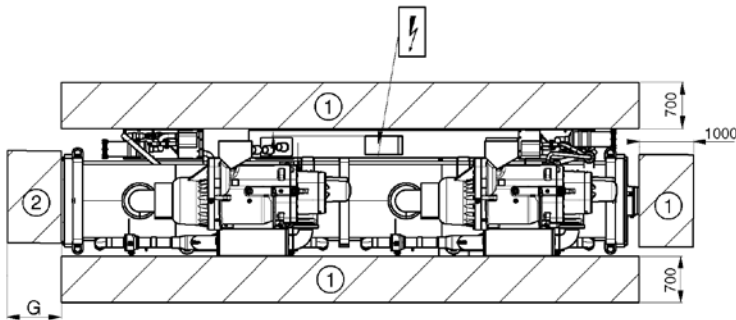
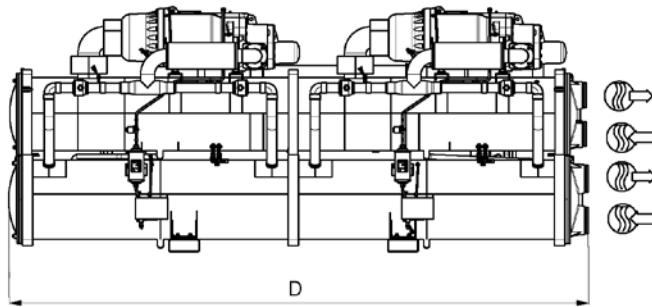
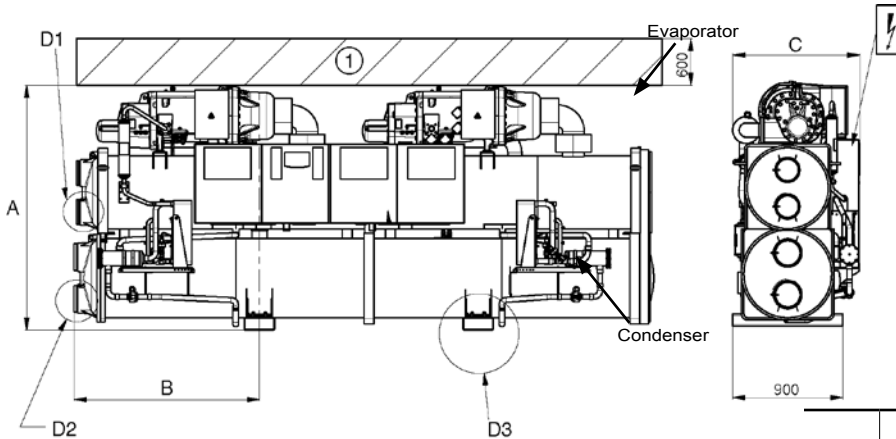

	Dimensions in mm						
	A	B	C	D	E	F	G
Standard-efficiency units 30XW--/30XWH-							
1002	1870	950	1036	4025	219.1	168.3	3800
1052	1870	950	1036	4025	219.1	168.3	3800
1152	1925	950	1036	4025	219.1	219.1	3800
1252	2051	1512	1162	4730	219.1	219.1	4500
1352	2051	1512	1162	4730	219.1	219.1	4500
1452	2051	1512	1162	4730	219.1	219.1	4500
1552	2051	1512	1162	4730	219.1	219.1	4500
High-efficiency units 30XW-P/30XWHP							
1012	1997	1512	1039	4730	219.1	219.1	4500
1162	1997	1512	1039	4730	219.1	219.1	4500
1314	2051	1512	1162	4730	219.1	219.1	4500
1464	2051	1512	1162	4730	219.1	219.1	4500
Standard-efficiency units 30XW--/30XWH- (option 150)							
1002	1870	950	1036	4025	219.1	168.3	3800
1052	1870	950	1036	4025	219.1	168.3	3800
1154	2925	950	1036	4025	219.1	219.1	3800
1252	2071	1512	1202	4730	219.1	219.1	4500
1352	2071	1512	1202	4730	219.1	219.1	4500
1452	2071	1512	1202	4730	219.1	219.1	4500
1552	2071	1512	1202	4730	219.1	219.1	4500
High-efficiency units 30XW-P/30XWHP (option 150)							
1012	1997	1512	1039	4730	219.1	219.1	4500
1162	1997	1512	1039	4730	219.1	219.1	4500
1314	2071	1512	1202	4730	219.1	219.1	4500
1464	2071	1512	1202	4730	219.1	219.1	4500

Legend

All dimensions are given in mm.

- ① Required clearance for maintenance
- ② Recommended clearance for tube removal
- Water inlet
- Water outlet
- Air outlet – do not obstruct
- Power supply connection

NOTE: Drawings are not contractually binding. Before designing an installation, consult the certified dimensional drawings, available on request.

DIMENSIONS/CLEARANCES

30XW--/30XWH- 1652-1702
30XW-P/30XWHP 1612-1762

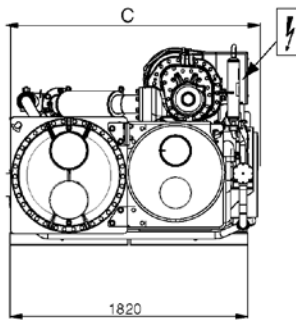
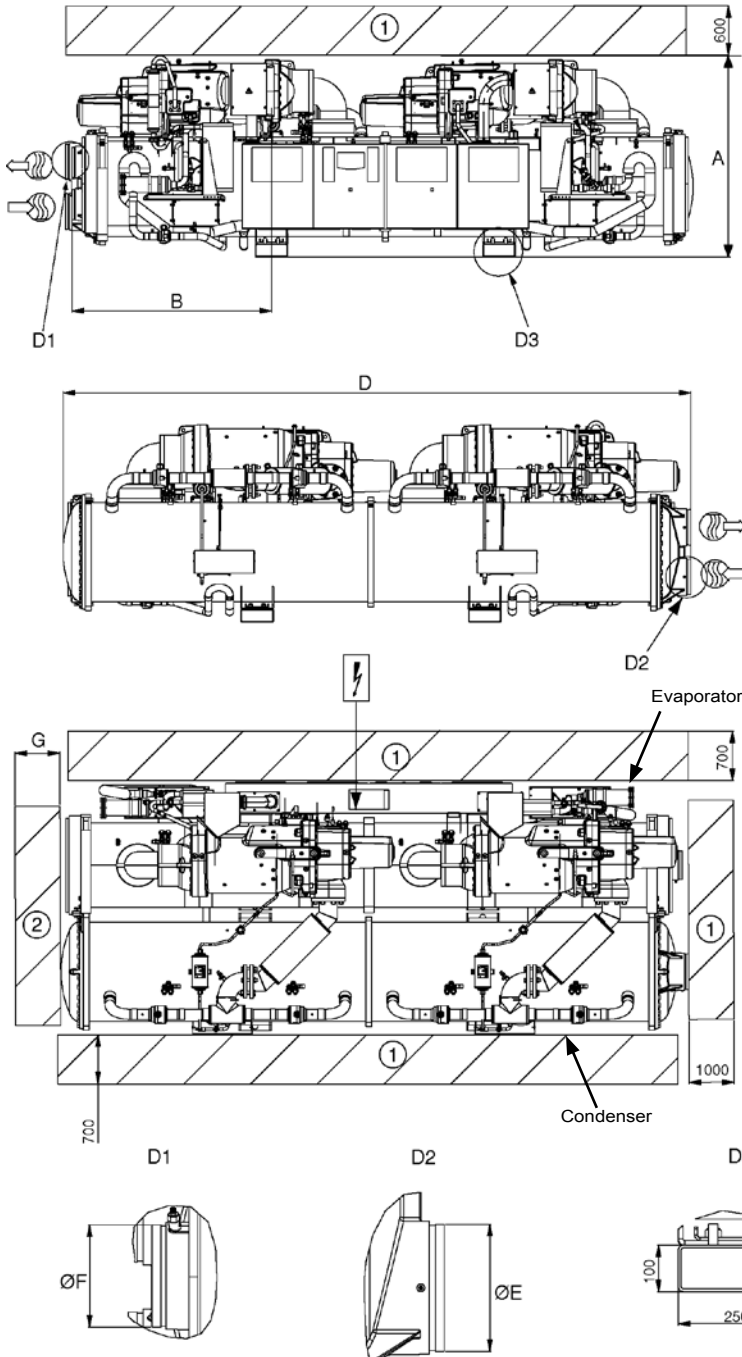

	Dimensions in mm						
	A	B	C	D	E	F	G
Standard-efficiency units 30XW--/30XWH-							
1652	1515	1568	1902	4790	219.1	219.1	4500
1702	1515	1568	1902	4790	219.1	219.1	4500
High-efficiency units 30XW-P/30XWHP							
1612	1562	1591	2129	4832	273.1	273.1	4600
1762	1562	1591	2129	4832	273.1	273.1	4600
Standard-efficiency units 30XW--/30XWH- (option 150)							
1652	1535	1568	1947	4790	219.1	219.1	4500
1702	1535	1568	1947	4790	219.1	219.1	4500
High-efficiency units 30XW-P/30XWHP (option 150)							
1612	1585	1591	2174	4832	273.1	273.1	4600
1762	1585	1591	2174	4832	273.1	273.1	4600

Legend

All dimensions are given in mm.

- ① Required clearance for maintenance
- ② Recommended clearance for tube removal
- ← Water inlet
- Water outlet
-))) Air outlet – do not obstruct
- ⚡ Power supply connection

NOTE: Drawings are not contractually binding. Before designing an installation, consult the certified dimensional drawings, available on request.

SPECIFICATION GUIDE

General description

(30XW / 30XW-P) Factory assembled single piece water-cooled chiller, shall include all factory wiring, piping, controls, refrigerant charge (HFC-134a), refrigeration circuits, screw compressors, electronic expansion valves and equipment required prior to field start-up.

(30XWH / 30XWHP) Factory assembled single piece water-sourced heat pump, shall include all factory wiring, piping, controls, refrigerant charge (HFC-134a), refrigeration circuits, screw compressors, electronic expansion valves and equipment required prior to field start-up.

Quality assurance

Unit construction shall comply with European directives:

- Pressurized equipment directive (PED) 2014/68/EU
- Machinery directive 2014/35/EU, modified
- Low voltage directive 2006/95/EC, modified
- Electromagnetic compatibility directive 2014/30/EU, modified, and the applicable recommendations of European standards
- Machine safety: electrical equipment in machines, general requirements, EN 60204-1
- Electromagnetic compatibility emission EN61000-6-4
- Electromagnetic compatibility immunity EN61000-6-2

Unit shall be designed, manufactured and tested in a facility with a quality management system certified ISO 9001 and environmental management system ISO 14001.

Unit shall be run tested at the factory.

Design performance data

- Cooling capacity (kW):
- Unit power input (kW):
- Full load energy efficiency, EER (kW/kW):
- Part load energy efficiency "comfort", SEER (kW/kW):
- Part load energy efficiency "process", SEPR (kW/kW):
- Evaporator entering/leaving water temperature (°C): ... /
- Fluid type:
- Fluid flow rate (l/s):
- Evaporator pressure drops (kPa):
- Condenser entering/leaving water temperature (°C):
- Fluid type:
- Fluid flow rate (l/s):
- Full load energy efficiency, COP(kW/kW):
- Part load energy efficiency, SCOP(kW/kW):
- Condenser pressure drops (kPa):
- Sound power level at full load (dB(A)):
- Dimensions, length x depth x height (mm): ... x ... x

Performance shall be declared in accordance with EN14511-3:2013 and certified by Eurovent up to 1500 kW.

The unit shall be capable of starting with 13 °C entering water temperature to the condenser with condenser head pressure control option. The unit shall be capable of starting with 35 °C entering water temperature to the evaporator.

The machine shall operate with condenser leaving water temperature up to 50 °C.

- (*Carrier option 150*) The machine shall operate with condenser leaving water temperature up to 63 °C.
- (*Carrier option 5*) The unit shall permit chilled brine solution production down to -6 °C when ethylene glycol is used, or down to -3 °C when propylene glycol is used.
- (*Carrier option 6*) The unit shall permit chilled brine solution production down to -12 °C when ethylene glycol is used, or down to -8 °C when propylene glycol is used.

Frame

- Machine frame shall include heat exchangers and compressors in a self-supporting structure
- Electrical panel doors shall be accessible by 1/4-turn screws

Compressor

- Unit shall have semi-hermetic twin-screw compressors with internal relief valve and check valve to avoid reverse rotation on shut down
- Each compressor shall be equipped with a discharge shut-off valve
- The discharge shall also be equipped with a muffler to reduce discharge gas pulsations
- Compressor bearings shall be designed for minimum 73000 hours at maximum operating conditions
- Capacity control shall be provided by a slide valve
- Compressor capacity control shall be stepless from 100% to 15% load
- Compressor shall start in unloaded condition
- Motor shall be cooled by suction gas and protected through a dedicated electronic board against the following: thermal overload by internal winding temperature sensors, electrical overload and short circuit by dedicated fuses (one per phase), reverse rotation, loss of phase, undervoltage and power supply failure
- Lubrication oil system shall include pre-filter and external filter capable of filtration to 5 microns
- The oil filter line shall be equipped with service shut off valves for easy filter replacement
- The oil separator, shall be integrated in the condenser design and shall not require oil pump
- The oil separator shall include an oil level safety switch.

Evaporator

- Unit shall be equipped with a single flooded evaporator
- Evaporator shall be manufactured by the chiller manufacturer
- Evaporator shall be tested and stamped in accordance with the European directive for pressurized equipment 2014/68/EU
- The maximum refrigerant-side operating pressure will be 2100 kPa, and the maximum waterside pressure will be 1000 kPa (2100kPa as an option)
- The evaporator shall be mechanically cleanable, shell-and-tube type with removable heads
- Tubes shall be internally and externally grooved, seamless-copper, and shall be rolled into tube sheets
- Shell shall be insulated with 19 mm closed-cell foam with a maximum K factor of 0.28. Evaporator thermal insulation shall be factory fitted
- The evaporator shall have a drain and vent in each head
- Chiller shall have only one water inlet & outlet connection with Victaulic couplings to avoid vibrations transmission and to accommodate minor pipework misalignment (Victaulic adapter kit shall be available on demand)
- The evaporator shall incorporate an indirect refrigerant level control system (based on the continuous measurement of the approach value) to ensure optimum heat transfer performance under all load conditions
- Design shall incorporate either 1 or 2 independent refrigerant circuits
- Evaporator shall be fitted with electronic auto setting water flow switch. Paddle switches or differential pressure switches shall not be acceptable.

Condenser

- Unit shall be equipped with a single condenser
- Condenser shall be manufactured by the chiller manufacturer

SPECIFICATION GUIDE

- Condenser shall be tested and stamped in accordance with the European directive for pressurized equipment 2014/68/EU
- Single pass or 2-passes design shall be possible
- The maximum refrigerant-side operating pressure will be 2100 kPa, and the maximum waterside pressure will be 1000 kPa (2100kPa as an option)
- The condenser shall be mechanically cleanable shell-and-tube type with removable heads
- Tubes shall be internally and externally grooved, seamless-copper, and shall be rolled into tube sheets
- The condenser shall have a drain and vent in each head
- Chiller shall have only one water inlet & outlet connection with Victaulic couplings to avoid vibrations transmission and to accommodate minor pipework misalignment (Victaulic adapter kit shall be available on demand)
- Design shall incorporate either 1 or 2 independent refrigerant circuits and the oil separator.

Refrigerant circuit

- Refrigerant circuit components shall include: compressor, oil separator, high and low side pressure relief devices, economizer, filter driers, moisture indicating sight glasses, long stroke electronic expansion device, and complete operating charge of both refrigerant R134a and compressor oil
- (*Carrier option 92*) A compressor suction and discharge line shut off valve, an evaporator inlet valve and economizer line valve, shall be mounted to isolate all main components (filter drier, oil filter, expansion device and compressor) and allow refrigerant to be safely stored during service operation
- (*Carrier option 257*) Evaporator and refrigerant gas suction line shall be acoustically insulated.

Power control box

- Unit shall operate at 400 Volts (+/- 10%), 3-phases, 50 Hertz power supply without neutral
- Unit shall be designed for simplified connection on TN(s) networks
- Control circuit voltage shall be 24 V maximum, supplied by a factory-installed transformer
- Unit shall be supplied with factory-installed main circuit breaker/isolator
- Unit shall have single point power connection (*Carrier option 81* for sizes 1002/1762)
- Unit shall have a factory installed star/delta starter as standard to limit electrical inrush current
- Power control box is powered painted with hinged and gasket sealed doors and is protected to IP23.

Controls

- Unit control shall include as a minimum: microprocessor with non-volatile memory, picture guided unit/operator interface, the LOCAL/OFF/REMOTE/CCN selector and a 5 inches coloured touch-screen display with multiple language capability
- Pressure sensors shall be installed to measure suction, discharge, and oil pressure
- Temperature probes shall be installed to read cooler/condenser entering and leaving temperatures.
- (*Carrier option 158A*) Unit control shall include as a minimum: microprocessor with non-volatile memory, picture guided unit/operator interface, the LOCAL/OFF/REMOTE/CCN selector and a 7 inches coloured touch-screen display with multiple language capability
- Unit control shall have an IP port to permit user connection via web browser, allowing same level of access to control

menus as unit mounted interface (excluding start/stop and alarm reset capabilities)

- Control shall store technical documentation, drawings and spare parts list specific to each particular unit
- (*Carrier option 148B*) A two-directional communication board shall allow plug and play interfacing of the machine with any BMS using the J-Bus protocol
- (*Carrier option 148D*) A two-directional communication board shall allow plug and play interfacing of the machine with any BMS using the LonTalk protocol
- (*Carrier option 149*) Machine shall be supplied with factory-installed two-directional high-speed communication using BACnet protocol over Ethernet network (IP-connection). The BACnet over-IP communication shall have no limitation in reading/writing controller points and shall use standardized alarm codes as defined with BACnet protocol. Filed programming shall be required.
- (*Carrier option 298*) Machine shall be accessible via wireless connection for remote monitoring with the scope of preventive maintenance.

Unit shall be capable of performing the following functions:

- Electronic expansion valve control optimizing evaporator refrigerant charge while ensuring minimum refrigerant superheat and optimum subcooling at condenser outlet
- Capacity control based on leaving chilled fluid temperature
- Limitation of the chilled fluid-temperature pull-down rate at start-up to an adjustable range of 0.1°C to 1.1°C per minute to prevent excessive demand spikes at start-up
- Automatic change-over and cycling of compressors to equalize running hours and number of starts
- Reset enable of leaving chilled-water temperature based on the outdoor air temperature or via 0-10 V signal (as option)
- Dual set point management for the leaving chilled water temperature activated by a remote contact closure signal or by the built in time clock
- 2-level demand limit control (between 0 and 100%) activated by remote contact closure or by the built in time clock
- Time scheduling management to enable unit start-up control, demand limit and set-point changes
- Trending of main variables
- (*Carrier option 58*) lead/lag type control of two chillers running in series or parallel
- (*Carrier option 84*) Water pump control, safety pumps (if installed) on both condenser and cooler side
- (*Carrier option 156*) The following inputs contacts shall be available on the unit control board:
 - Setpoint reset by indoor air temperature sensor
 - Cooling setpoint reset by 4-20 mA
 - Time schedule override
 - Ice storage input
 - Demand limit
 - Unit shut down

The following outputs contacts shall be available on the unit control board:

- Instantaneous chiller capacity by 0-10 V signal
- Complete shut-down due to a chiller fault
- Compressor operation indication.

Diagnosis

- Control interface shall be capable of displaying set points, system status including temperatures, pressures, current for each compressor, run time and percent loading
- Control interface shall perform trending of up to 10 preselected variables
- Control system shall allow a quick test of all machine elements to verify the correct operation of every switch, circuit breaker, contactor etc. before the chiller is started

SPECIFICATION GUIDE

- In case of alarm, control system shall send an email to specific mail box set by user during machine commissioning
- Control shall have black box function which permit to store data set of 20 variables with interval of 5 seconds, during 14 minutes preceeding the alarm and 1 minute following the alarm event. The black box recording capability shall permit recording for 20 events and once the threshold is reached new data shall over-write the oldest ones.

Safeties

Control system shall provide the unit with protection against the following:

- Reverse rotation
- Low chilled water temperature
- Low oil pressure (per compressor)
- Current imbalance
- Compressor thermal overload
- High pressure (with automatic compressor unloading in case of excessive condensing temperature)
- Electrical overload and short circuit
- Loss of phase, undervoltage and power supply failure
- Control shall provide separate general alert (minor incident) and alarm (circuit down) remote indication.



Order No.: 13457, 02.2018. Supersedes order No.: 13457, 03.2017.
Manufacturer reserves the right to change any product specifications without notice.

Manufactured by: Carrier SCS, Montluel, France.
Printed in the European Union.



Quality and Environment
Management Systems
Approval