

**40RM/RMS
Packaged Air-Handling Units
50/60 Hz
6 to 30 Nominal Tons (21 to 105 kW)**

Carrier

turn to the experts™

Product Data

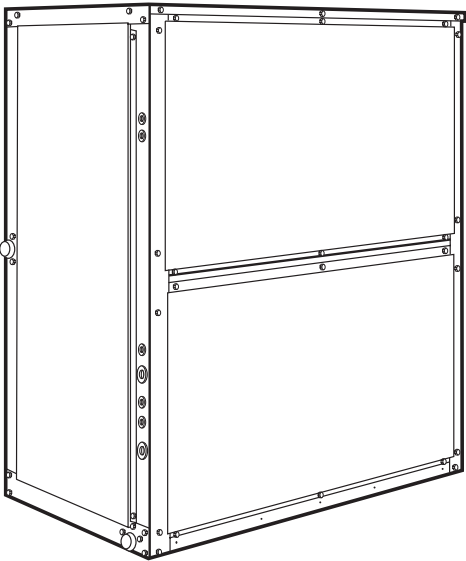

40RM007S-012S
40RMS008S-012S

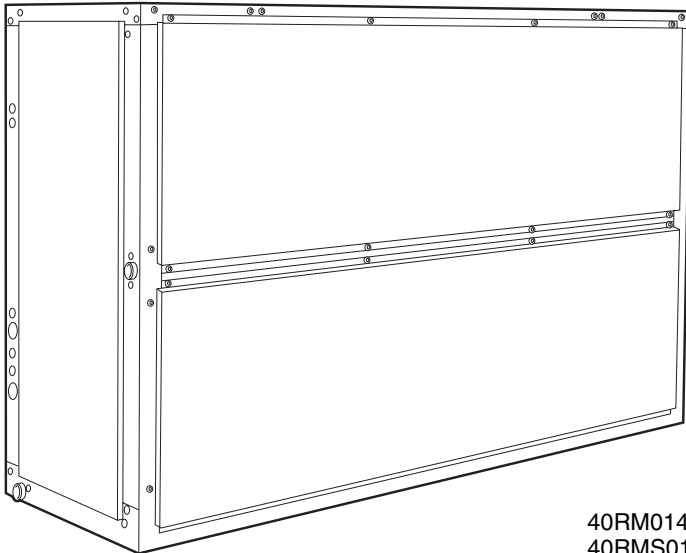

40RM014S-034S
40RMS014S-034S

Features / Benefits

- Multiposition design can be installed horizontally or vertically without modification
- Standard double skin units for a better indoor air quality (IAQ)
- Polyester powder painted zinc coated steel panels provide additional protection against rusting & discoloration in areas with high UV factor
- High-static design meets a wider range of applications than competitive packaged air handler lines
- Economizer accessory provides ventilation air and "free" cooling
- Cooling coils with mechanically-bonded fins provide peak heat transfer
- Standard factory-installed thermostatic expansion valves (TXVs) on 40RM units
- Standard sloped drain pans
- 1" WASHABLE filters having frontal access to remove them
- Easy installation and maintenance; removal of one side panel allows access to serviceable components; external piping connections

The 40RM Series is your best choice for packaged air handlers. Model 40RM units have direct-expansion coils and model 40RMS units have chilled water coils. All models offer excellent fan performance, a unique combination of indoor air quality features, easy installation, and affordable prices. Their versatility and state-of-the-art features will provide economical performance now and in the future.

Indoor air quality features:

The unique combination of features in the 40RM Series air handlers ensure that clean, fresh, conditioned air is delivered to the occupied space.

Cooling coils prevent the build-up of humidity in the room, even during part-load conditions. Unit sizes of 10 tons and above feature dual-circuit face-split coils.

1 inch (25.4 mm) WASHABLE air filters remove dust and airborne particles from the occupied space.

Standard double skin units provide an excellent resistance from the air-borne particles off the insulation thus maintaining an excellent indoor air quality (IAQ).

Pitched drain pan can be adjusted for a right- or left-hand connection to provide positive drainage and prevent standing condensate.

Accessory economizer can provide ventilation air to improve indoor air quality. When used with CO₂ sensors, the economizer admits fresh outdoor air to replace stale, recirculated indoor air.

Economy

The 40RM Series packaged air handlers have low initial costs, and they continue to save money by providing reduced installation expense and energy-efficient performance.

Quick installation is ensured by the multiposition design. Units can be installed in either the horizontal or vertical (upflow) configuration without modifications. All units have drain-pan connections on both sides, and pans can be pitched for right- or left-hand operation with a simple adjustment. Fan motors and contactors are prewired and TXVs are factory-installed on 40RM models.

High efficiency, precision-balanced fans minimize air turbulence, surging and unbalanced operation, thereby cutting operating expenses.

Economizer accessory precisely controls the blend of outdoor air and room air to achieve comfort levels. When the outside air enthalpy is suitable, outside air dampers can fully open to provide "free" cooling.

Rugged dependability

Polyester powder painted (zinc coated) panels provide excellent resistance to corrosion and also protect the colour in the areas where ultra-violet (UV) radiation factor is high.

Mechanically bonded coil fins provide improved heat transfer.

Galvanized steel fan housings are securely mounted to a die-formed galvanized steel deck.

Rugged pillow-block bearings (014-034 sizes) are securely fastened to the solid steel fan shaft with split collets and clamp locking devices.

Smaller unit size shave spider-type bearings.

Coil flexibility

Model 40RM (direct-expansion coils) and 40RMS (chilled water coils) have galvanized steel casings; inlet and outlet connections are external & on the same end.

Chilled water coils have 1/2 in. (12.7 mm) diameter copper tubes mechanically bonded to aluminum sine-wave fins. All coils have non-ferrous headers.

Direct expansion (DX) coils are designed for use with Refrigerant 22 and have copper tubes mechanically bonded to aluminum sine-wave fins. Direct-expansion coils include matched, factory-installed thermostatic expansion valves (TXVs) with matching distributor nozzles.

Easier installation and service:

The multi-position design and component layout help you to get the unit installed and running quickly. The DX coils have factory-installed TXVs with matching distributor nozzles. Units can be converted from horizontal to vertical operation by simply repositioning the unit. Drain pan connections are duplicated on both sides of the unit. The filters, motor, drive, TXVs, and coil connections are easily accessed by removing a single side panels.

Table of contents

	Page
Features/Benefits	1, 2
Model Number Nomenclature	3
Physical Data	4-7
Options and Accessories	8-10
Dimensions	11-20
Selection Procedure	21,22
Performance Data	23-39
Electrical Data	40-46
Typical Piping and Wiring	47-50
Application Data	51-59
Guide Specifications	60,61

Model number nomenclature

4 0 R M - 0 1 6 S D B 5 0 1 E D

40RM Commercial Packaged Air Handler

Cooling Coil

- Direct Expansion
- S** Chilled Water

Nominal Capacity		Tons (kW)	
007	6 (21)	016	15 (52)
008	7-1/2 (26)	024	20 (70)
010	8-1/2 (29)	028	25 (87)
012	10 (35)	034	30 (105)
014	12-1/2 (43)		

S: SAMCO

D: Double Skin

Expansion Device

- None (40RMS)
- B** Thermostatic Expansion Valves (40RM)

Voltage Designation (V-Ph-Hz)

- 3** 208/230-1-60 (007-010 sizes only)
- 5** 208/230-3-60
- 6** 208/230/460-3-60 (all sizes 007-014; size 016 except YC and WD options)
460-3-60 (sizes 016 with YC or WD options and all size 024-034 units)
- 8** 230-3-50
- 9** 400-3-50

Revision Number

- 0** Original Model

Factory-Installed Options

- ED** Painted, Standard Motor and Standard Drive
- FD** Painted, Standard Motor and Medium-Static Drive (Not available for 028 size for 60 Hz units and 016-028 for 50 Hz units)
- RD** Painted, Alternate Motor and Medium-Static Drive (Available for 50 Hz sizes 016,024,028 and 60 Hz size 028 only)
- WD** Painted, Alternate Motor and High-Static Drive

Packaging

- 1** Standard Domestic
- 3** Export

40RM/RMS

²YC and WD option codes for all 034 size units and 008, 010 units with 208/230-1-60 power designate standard motor and high-static drive.

NOTE: See the following table for the sizes available for each unit.

UNIT SIZE AVAILABILITY

UNIT	007	008	010	012	014	016	024	028	034
40RM	X	X		X	X	X	X	X	X
40RMS		X	X	X	X	X	X	X	X



Physical data

40RM - ENGLISH

UNIT 40RM	007SD	008SD	012SD	014SD	016SD	024SD	028SD	034SD
NOMINAL CAPACITY (Tons)	6	7½	10	12½	15	20	25	30
OPERATING WEIGHT (lb)								
Base Unit (Double skin) with TXV	448	452	472	804	819	824	1188	1198
Plenum	97	97	97	140	140	140	180	180
FANS								
Qty...Diam. (in.)	1...15	1...15	1...15	2...15	2...15	2...15	2...18	2...18
Nominal Airflow (cfm)	2400	3000	4000	5000	6000	8000	10,000	12,000
Airflow Range (cfm)	1800-3000	2250-3750	3000-5000	3750-6250	4500-7500	6000-10,000	7500-12,500	9000-15,000
Nominal Motor Hp (Standard Motor)*								
208/230-1-60	1.3	2.4	-	-	-	-	-	-
208/230-3-60 and 460-3-60	2.4	2.4	2.4	2.9	3.7	5.0	7.5	10.0
575-3-60	1.0	2.0	2.0	3.0	3.0	5.0	7.5	10.0
230-3-50, 400-3-50	2.4	2.4	2.9	2.9	2.9	5.0	7.5	10.0
Motor Speed (rpm)								
208/230-1-60	1725	1725	-	-	-	-	-	-
208/230-3-60 and 460-3-60	1725	1725	1725	1725	1725	1745	1745	1745
575-3-60	1725	1725	1725	1725	1725	1745	1755	1755
230-3-50, 400-3-50					1425			
REFRIGERANT								
Operating charge (lb) (approx per circuit) ²	3.0	3.0	1.5/1.5	2.0/2.0	R-22 2.5/2.5	3.5/3.5	4.5/4.5	5.0/5.0
DIRECT-EXPANSION COIL	Enhanced Copper Tubes, Aluminum Sine-Wave Fins							
Max Working Pressure (psig)	435							
Face Area (sq ft)	6.67	8.33	10.0	13.25	17.67	19.88	24.86	29.83
No. of Splits	1	1	2	2	2	2	2	2
Split Type...Percentage	-	-	-	-	-	Face...50/50	-	-
No. of Circuits per Split	12	15	9	9	12	13	15	18
Rows...Fins/in.	3...15	3...15	3...17	3...15	3...15	3...17	3...15	3...15
STEAM COIL**								
Max Working Pressure (psig at 400 F)	175							
Total Face Area (sq ft)	6.67	6.67	6.67	13.33	13.33	13.33	15.0	15.0
Rows...Fins/in.	1...9	1...9	1...9	1...10	1...10	1...10	1...10	1...10
HOT WATER COIL**								
Max Working Pressure (psig)	150							
Total Face Area (sq ft)	6.67	6.67	6.67	13.33	13.33	13.33	15.0	15.0
Rows...Fins/in.	2...8.5	2...8.5	2...8.5	2...8.5	2...8.5	2...8.5	2...12.5	2...12.5
Water Volume (gal)		8.3			13.9		14.3	
(ft ³)		1.1			1.85		1.90	
PIPING CONNECTIONS								
Quantity...Size (in.)								
DX Coil - Suction (ODF)	1...1½	1...1½	2...1½	2...1½	2...1½	2...1½	2...1¾	2...1¾
DX Coil - Liquid Refrigerant (ODF)	1...5/8					2...5/8		
Steam Coil, In (MPT)	1...2½					1...2½		
Steam Coil, Out (MPT)	1...1½					1...1½		
Hot Water Coil, In (MPT)	1...1½		1...1½				1...2	
Hot Water Coil, Out (MPT)	1...1½		1...1½				1...2	
Condensate (PVC)					1...1¼ ODM/1 IDF			
FILTERS								
Quantity...Size (in.)		4...16 x 24 x 1		Washable	-	Factory Supplied		
Access Location						4...16 x 20 x 1	4...20 x 24 x 1	
						4...16 x 24 x 1	4...20 x 25 x 1	
						Front		

LEGEND

DX - Direct Expansion
TXV - Thermostatic Expansion Valve

*Refer to alternate Fan Motor Data table, pages 52 and 53, for alternate motor data.

²Units are shipped without refrigerant charge.

**Please contact your local Carrier sales office for availability.

Please contact your local Carrier sales office for the weights of single skin units.

40RM/RMS

40RM - SI

UNIT 40RM	007SD	008SD	012SD	014SD	016SD	024SD	028SD	034SD
NOMINAL CAPACITY (kW)	21	26	35	43	52	70	87	105
OPERATING WEIGHT (kg)								
Base Unit (Double skin) with TXV	203	205	214	364	371	373	538	542
Plenum	44	44	44	63	63	63	82	82
FANS								
Qty...Diam. (mm)	1...381	1...381	1...381	2...381	2...381	2...381	2...457	2...457
Nominal Airflow (L/s)	1133	1604	1888	2360	2831	3775	4719	5663
Airflow Range (L/s)	850-1416	1203-2006	1416-2360	1770-2949	2124-3539	2831-4719	3539-5899	4247-7079
Nominal Motor kW (Standard Motor)*								
208/230-1-60	0.97	1.79	-	-	-	-	-	-
208/230-3-60 and 460-3-60	1.79	1.79	1.79	2.16	2.76	3.73	5.59	7.46
575-3-60	0.75	1.49	1.49	2.24	2.24	3.73	5.59	7.46
230-3-50, 400-3-50	1.79	1.79	2.16	2.16	2.16	3.73	5.59	7.46
Motor Speed (r/s)								
208/230-1-60	28.8	28.8	-	-	-	-	-	-
208/230-3-60 and 460-3-60	28.8	28.8	28.8	28.8	28.8	29.1	29.1	29.1
575-3-60	28.8	28.8	28.8	28.8	28.8	29.1	29.3	29.3
230-3-50, 400-3-50	23.8	23.8	23.8	23.8	23.8	23.8	23.8	23.8
REFRIGERANT								
Operating charge (kg) (approx per circuit) ²	1.36	1.36	0.68/0.68	0.90/0.90	1.13/1.13	1.59/1.59	2.04/2.04	2.27/2.27
					R-22			
DIRECT-EXPANSION COIL								
Max Working Pressure (kPag)					Enhanced Copper Tubes, Aluminum Sine-Wave Fins			
Face Area (sq m)	0.62	0.77	0.93	0.93	1.64	1.85	2.30	2.77
No. of Splits	1	1	2	2	2	2	2	2
No. of Circuits per Split	12	15	9	9	12	13	15	18
Split Type...Percentage	-	-	-	-	Face...50/50			
Rows...Fins/m	3...591	3...591	3...670	3...591	3...591	3...670	3...591	3...591
STEAM COIL***								
Max Working Pressure (kPag at 204.4 C)					1207			
Total Face Area (sq m)	0.62	0.62	0.62	1.24	1.24	1.24	1.39	1.39
Rows...Fins/m	1...355	1...355	1...355	1...394	1...394	1...394	1...394	1...394
HOT WATER COIL***								
Max Working Pressure (kPag)					1034			
Total Face Area (sq m)	0.62	0.62	0.62	1.24	1.24	1.24	1.39	1.39
Rows...Fins/m	2...335	2...335	2...335	2...335	2...335	2...335	2...493	2...493
Water Volume								
(L)		31.4			52.6		54.1	
(m ³)		0.031			0.052		0.054	
PIPING CONNECTIONS**								
Quantity...Size (in.)								
DX Coil - Suction (ODF)	1...1 ¹ / ₈	1...1 ¹ / ₈	2...1 ¹ / ₈	2...1 ¹ / ₈	2...1 ¹ / ₈	2...1 ¹ / ₈	2...1 ³ / ₈	2...1 ³ / ₈
DX Coil - Liquid Refrigerant (ODF)	1... ⁵ / ₈				2... ⁵ / ₈			
Steam Coil, In (MPT)	1...2 ¹ / ₂				1...2 ¹ / ₂			
Steam Coil, Out (MPT)	1...1 ¹ / ₂				1...1 ¹ / ₂			
Hot Water Coil, In (MPT)	1...1 ¹ / ₂		1...1 ¹ / ₂			1...2		
Hot Water Coil, Out (MPT)	1...1 ¹ / ₂		1...1 ¹ / ₂			1...2		
Condensate (PVC)					1...1 ¹ / ₄ ODM/1 IDF			
FILTERS								
Quantity...Size		4...406 x 610 x 25.4		Washable	-	Factory Supplied		
Access Location						4...406 x 508 x 25.4	4...508 x 610 x 25.4	
						4...406 x 610 x 25.4	4...508 x 635 x 25.4	
						Front		

LEGEND

DX - Direct Expansion
TXV - Thermostatic Expansion Valve

*Refer to Alternate Fan Motor Data table, pages 56 and 57, for alternate motor data.

²Units are shipped without refrigerant charge.

**All piping sizes are OD inches; equivalent sizes in millimeters follow:

***Please contact your local Carrier sales office for availability.

in.	mm
⁵ / ₈	15.9
1	25.4
1 ¹ / ₈	28.6
1 ¹ / ₄	31.8
1 ³ / ₈	34.9
1 ¹ / ₂	38.1
2	50.8
2 ¹ / ₈	54.0
2 ¹ / ₂	63.5

Please contact your local Carrier sales office for the weights of single skin units.

40RM/RMS

Physical data (cont)

40RMS - ENGLISH

UNIT 40RMS	008SD	010SD	012SD	014SD	016SD	024SD	028SD	034SD
NOMINAL CAPACITY (Tons)	7 ^{1/2}	8 ^{1/2}	10	12 ^{1/2}	15	20	25	30
OPERATING WEIGHT (lb)								
Base Unit (Double skin)	457	458	458	795	811	817	1203	1210
Plenum	97	97	97	140	140	140	180	180
FANS								
Qty...Diam. (in.)	1...15	1...15	1...15	2...15	2...15	2...15	2...18	2...18
Nominal Airflow (cfm)	3000	3400	4000	5000	6000	8000	10,000	12,000
Airflow Range (cfm)	2250-3750	2250-4250	3000-5000	3750-6250	4500-7500	6000-10,000	7500-12,500	9000-15,000
Nominal Motor Hp (Standard Motor)*								
208/230-1-60	2.4	2.4	-	-	-	-	-	-
208/230-3-60 and 460-3-60	2.4	2.4	2.4	2.9	3.7	5.0	7.5	10.0
575-3-60	2.0	2.0	2.0	3.0	3.0	5.0	7.5	10.0
230-3-50, 400-3-50	2.4	2.4	2.9	2.9	2.9	5.0	7.5	10.0
Motor Speed (rpm)								
208/230-1-60	1725	1725	-	-	-	-	-	-
208/230-3-60 and 460-3-60	1725	1725	1725	1725	1725	1745	1745	1745
575-3-60	1725	1725	1725	1725	1725	1745	1755	1755
230-3-50, 400-3-50					1425			
CHILLED WATER COIL	Enhanced Copper Tubes, Aluminum Sine-Wave Fins							
Max Working Pressure (psig)	435							
Face Area (sq ft) - Upper	8.3	9.0	9.8	8.3	8.3	11.0	12.4	15.5
Face Area (sq ft) - Lower	-	-	-	5.5	8.3	8.3	12.4	12.4
Rows...Fins/in.	3...15							
Water Volume (gal)	3.0	3.3	3.5	4.7	5.6	6.4	8.9	9.9
(ft ³)	0.40	0.47	0.46	0.63	0.75	0.85	1.19	1.32
STEAM COIL**								
Max Working Pressure (psig at 400 F)	175							
Total Face Area (sq ft)	6.67	6.67	6.67	13.33	13.33	13.33	15.0	15.0
Rows...Fins/in.	1...9	1...9	1...9	1...10	1...10	1...10	1...10	1...10
HOT WATER COIL**								
Max Working Pressure (in. wg)	150							
Total Face Area (sq ft)	6.67	6.67	6.67	13.33	13.33	13.33	15.0	15.0
Rows...Fins/in.	2...8.5	2...8.5	2...8.5	2...8.5	2...8.5	2...8.5	2...12.5	2...12.5
Water Volume (gal)		8.3			13.9		14.3	
(ft ³)		1.1			1.85		1.90	
PIPING CONNECTIONS								
Quantity...Size (in.)								
Chilled Water - In	1...1 ^{3/8} ODF	1...1 ^{3/8} ODF	1...1 ^{3/8} ODF	2...1 ^{3/8} ODM	2...1 ^{3/8} ODM	2...1 ^{3/8} ODM	2...2 ^{1/8} ODM	2...2 ^{1/8} ODM
Chilled Water - Out	1...1 ^{3/8} ODF	1...1 ^{3/8} ODF	1...1 ^{3/8} ODF	2...1 ^{3/8} ODM	2...1 ^{3/8} ODM	2...1 ^{3/8} ODM	2...2 ^{1/8} ODM	2...2 ^{1/8} ODM
Steam Coil, In (MPT)	1...2 ^{1/2}				1...2 ^{1/2}			
Steam Coil, Out (MPT)	1...1 ^{1/2}				1...1 ^{1/2}			
Hot Water Coil, In (MPT)	1...1 ^{1/2}		1...1 ^{1/2}			1...2		
Hot Water Coil, Out (MPT)	1...1 ^{1/2}		1...1 ^{1/2}			1...2		
Condensate (PVC)	1...1 ^{1/4} ODM/1 IDF							
FILTERS								
Quantity...Size (in.)	4...16 x 24 x 1			Washable	Factory Supplied		4...20 x 24 x 1	
Access Location					4...16 x 20 x 1		4...20 x 25 x 1	
					4...16 x 24 x 1		Front	

*Refer to the Alternate Fan Motor Data table, pages 52 and 53, for alternate motor data.

**Please contact your local Carrier sales office for availability.

Please contact your local Carrier sales office for the weights of single skin units.

40RMS - SI

UNIT 40RMS	008SD	010SD	012SD	014SD	016SD	024SD	028SD	034SD
NOMINAL CAPACITY (kW)	26	29	35	43	52	70	87	105
OPERATING WEIGHT (kg)								
Base Unit (Double skin)	207	207	207	360	367	370	544	548
Plenum	44	44	44	63	63	63	82	82
FANS								
Qty...Diam. (mm)	1...381	1...381	1...381	2...381	2...381	2...381	2...457	2...457
Nominal Airflow (L/s)	1416	1605	1888	2360	2831	3775	4719	5663
Airflow Range (L/s)	1062-1770	1204-2006	1416-2360	1770-2949	2124-3539	2831-4719	3539-5899	4247-7079
Nominal Motor kW (Standard Motor)*								
208/230-1-60	1.79	1.79	-	-	-	-	-	-
208/230-3-60, 460-3-60	1.79	1.79	1.79	1.79	2.76	3.73	5.59	7.46
575-3-60	1.49	1.49	1.49	1.49	2.24	3.73	5.59	7.46
230-3-50, 400-3-50	1.79	1.79	2.16	2.16	2.16	3.73	5.59	7.46
Motor Speed (r/s)								
208/230-1-60	28.8	28.8	-	-	-	-	-	-
208/230-3-60, 460-3-60	28.8	28.8	28.8	28.8	28.8	29.1	29.1	29.1
575-3-60	28.8	28.8	28.8	28.8	28.8	29.1	29.3	29.3
230-3-50, 400-3-50	23.8	23.8	23.8	23.8	23.8	23.8	23.8	23.8
CHILLED WATER COIL								
Max Working Pressure (kPag)	2999							
Face Area (sq m) - Upper	0.77	0.84	0.91	0.77	0.77	1.02	1.15	1.44
Face Area (sq m) - Lower	-	-	-	0.51	0.77	0.77	1.15	1.15
Rows...Fins/m	3...591	3...591	3...591	3...591	3...591	3...591	3...591	3...591
Water Volume (L)	11.4	12.5	13.2	17.8	21.2	24.2	33.7	37.5
(m ³)	0.011	0.013	0.013	0.018	0.021	0.024	0.032	0.037
STEAM COIL**								
Max Working Pressure (kPag at 204.4 C)	1207							
Total Face Area (sq m)	0.62	0.62	0.62	1.24	1.24	1.24	1.39	1.39
Rows...Fins/m	1...355	1...355	1...355	1...355	1...394	1...394	1...394	1...394
HOT WATER COIL**								
Max Working Pressure (kPag)	1034							
Total Face Area (sq m)	0.62	0.62	0.62	1.24	1.24	1.24	1.39	1.39
Rows...Fins/m	2...335	2...335	2...335	2...335	2...335	2...335	2...493	2...493
Water Volume (L)		31.4			52.6		54.1	
(m ³)		0.031			0.052		0.054	
PIPING CONNECTIONS²								
Quantity...Size (in.)	1...1 ³ / ₈ ODF	1...1 ³ / ₈ ODF	2...1 ³ / ₈ ODF	2...1 ³ / ₈ ODM	2...1 ³ / ₈ ODM	2...1 ³ / ₈ ODM	2...2 ¹ / ₈ ODM	2...2 ¹ / ₈ ODM
Chilled Water - In	1...1 ³ / ₈ ODF	1...1 ³ / ₈ ODF	2...1 ³ / ₈ ODF	2...1 ³ / ₈ ODM	2...1 ³ / ₈ ODM	2...1 ³ / ₈ ODM	2...2 ¹ / ₈ ODM	2...2 ¹ / ₈ ODM
Chilled Water - Out								
Steam Coil, In (MPT)	1...2 ¹ / ₂				1...2 ¹ / ₂			
Steam Coil, Out (MPT)	1...1 ¹ / ₂				1...1 ¹ / ₂			
Hot Water Coil, In (MPT)	1...1 ¹ / ₂		1...1 ¹ / ₂			1...2		
Hot Water Coil, Out (MPT)	1...1 ¹ / ₂		1...1 ¹ / ₂			1...2		
Condensate (PVC)	1...1 ¹ / ₄ ODM/1 IDF							
FILTERS								
Quantity...Size (mm)	4...406 x 610 x 25.4			Washable - Factory Supplied 4...406 x 508 x 25.4 4...406 x 610 x 25.4			4...508 x 610 x 25.4 4...508 x 635 x 25.4	
Access Location				Front				

40RM/RMS

*Refer to the Alternate Fan Motor Data table, pages 52 and 53, for alternate motor data.

²All piping sizes are OD inches; equivalent sizes in millimeters follow:

**Please contact your local Carrier sales office for availability.

in.	mm
5/8	15.9
1	25.4
1 ¹ / ₈	28.6
1 ¹ / ₄	31.8
1 ³ / ₈	34.9
1 ¹ / ₂	38.1
2	50.8
2 ¹ / ₈	54.0
2 ¹ / ₂	63.5

Please contact your local Carrier sales office for the weights of single skin units.

Options and accessories

Factory-installed options

Alternate fan motors and drives are available to provide the widest possible range of performance.

Field-installed accessories

Two-row hot water coils have copper tubes mechanically bonded to aluminum plate fins and non-ferrous headers.

One-row steam coil has copper tubes and aluminum fins. The Inner Distributing Tube (IDT) design provides uniform temperatures across the coil face. The steam coil has a broad operating pressure range; up to 175 psig (1207 kPag) at 400 F (204.4 C) and up to 300 psig (2069 kPag) at 300 F (148.9 C). The IDT steam coils are especially suited to applications where sub-freezing air enters the unit.

Electric resistance heat coils have an open-wire design and are mounted in a rigid frame. Safety cutouts for high temperature conditions are standard. Terminal block for single-point power connection is included.

Economizer (enthalpy controlled) provides ventilation air and "free" cooling if outside ambient temperature and humidity are suitable. Can also be used with CO₂ sensors to help meet indoor air quality requirements.

Discharge plenum directs the air discharge directly into the occupied space; integral horizontal and vertical louvers enable redirection of airflow. Accessory is available unpainted or painted. Field assembly required.

Standard units available from the factory are in Double skin.

Return-air grille provides a protective barrier over the return-air opening and gives a finished appearance to units installed in the occupied space. Accessory is available unpainted or painted.

Subbase provides a stable, raised platform and room for condensate drain trap connection for vertical floor-mounted units. Accessory is available unpainted or painted.

Over head suspension package includes necessary brackets to support units in horizontal ceiling installations.

CO₂ sensors can be used in conjunction with the economizer accessory to help meet indoor air quality requirements. The sensor signals the economizer to open when the CO₂ level in the space exceeds the set point. A Carrier Comfort System programmable thermostat can be used to override the sensor if the outside air temperature is too high or too low.

Carrier's line of thermostats provide both programmable and non-programmable capability with the new Debonair line of commercial programmable thermostats, the TEMP System controls offer communication capability with staged heating and cooling, the Commercial Electronic thermostats provide 7-day programmable capability for economical applications, while the Non-Programmable thermostats offer a multitude of staged heating and cooling subbase options.

Condensate drain trap includes an overflow shutoff switch that can be wired to turn off the unit if the trap becomes plugged. Kit also includes a wire harness that can be connected to an alarm if desired. The transparent trap is designed for easy service and maintenance.

CARRIER THERMOSTATS

DEBONAIR COMMERCIAL PROGRAMMABLE THERMOSTAT

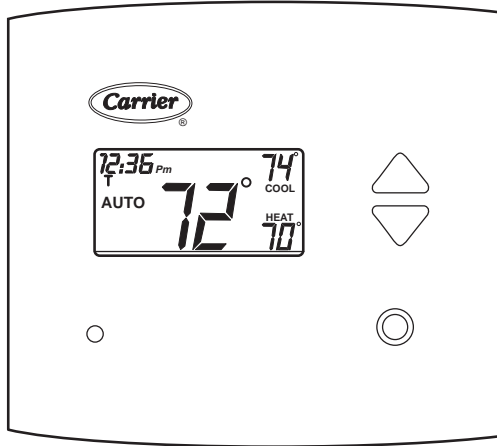

COMMERCIAL ELECTRONIC THERMOSTAT

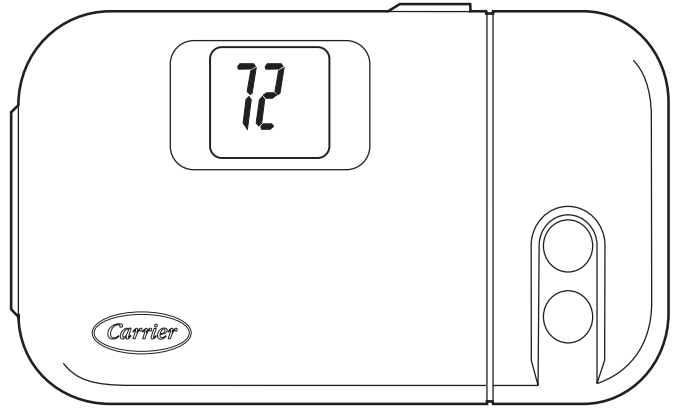

TEMP SYSTEM THERMOSTAT

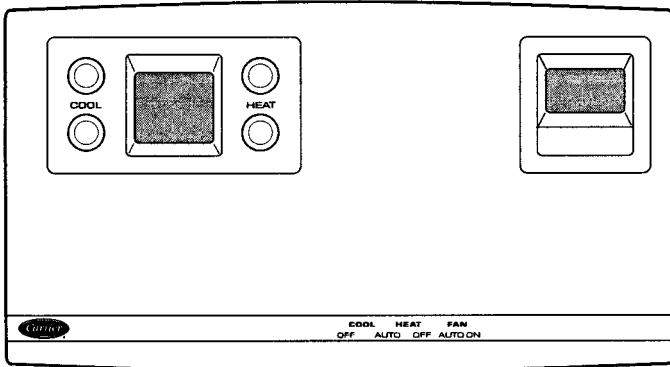

NON-PROGRAMMABLE THERMOSTAT

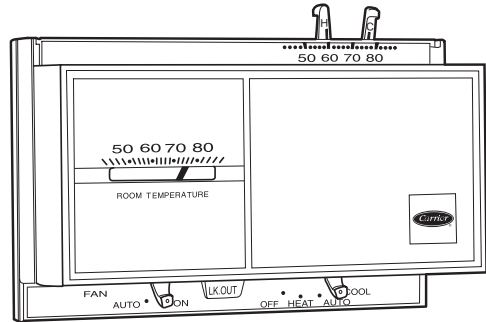

40RM/RMS

Options and accessories (cont)

40RM WITH DISCHARGE PLENUM, RETURN-AIR GRILLE AND SUBBASE

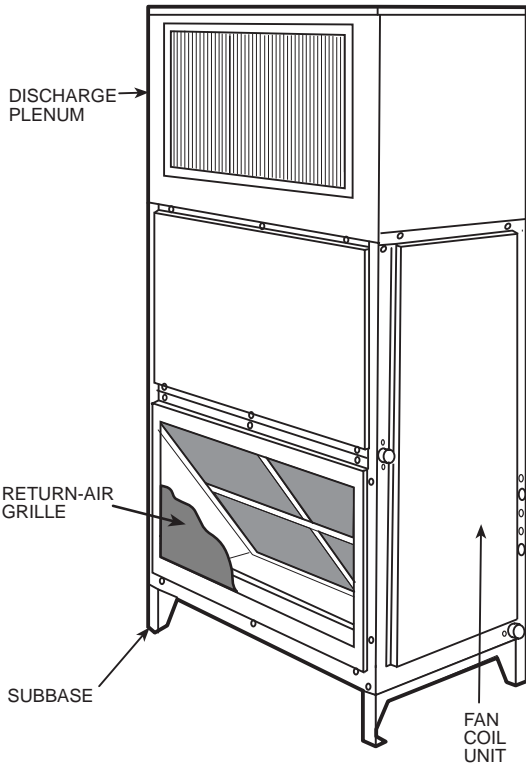

40RM WITH HOT WATER OR STEAM COIL



40RM WITH ECONOMIZER

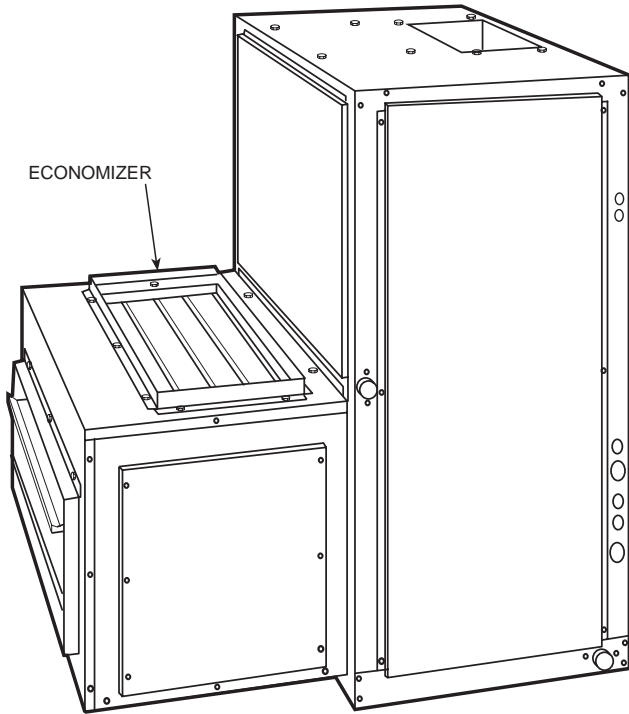

40RM WITH CONDENSATE TRAP

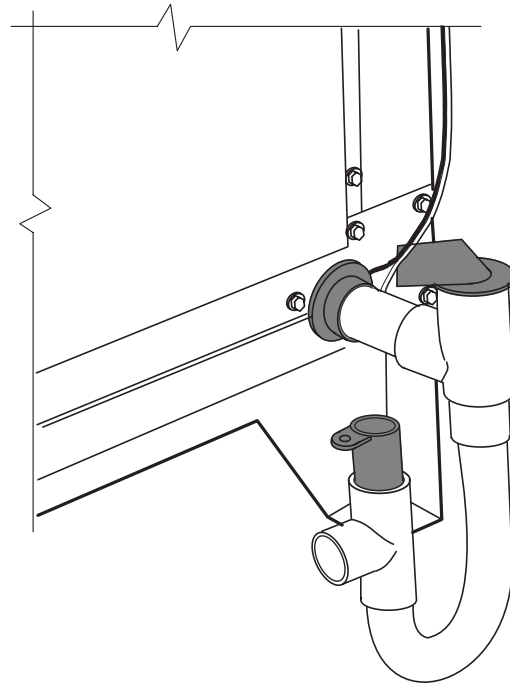

40RM/RMS

Dimensions

40RM007SD-012SD
40RMS008SD-012SD

UNIT	UNIT WEIGHT lb (kg)
40RM007SD	448 (203)
40RM008SD	452 (205)
40RM012SD	472 (214)
40RMS008SD	457 (207)
40RMS010SD	458 (207)
40RMS012SD	458 (207)

All the above mentioned weights are for double skin units.

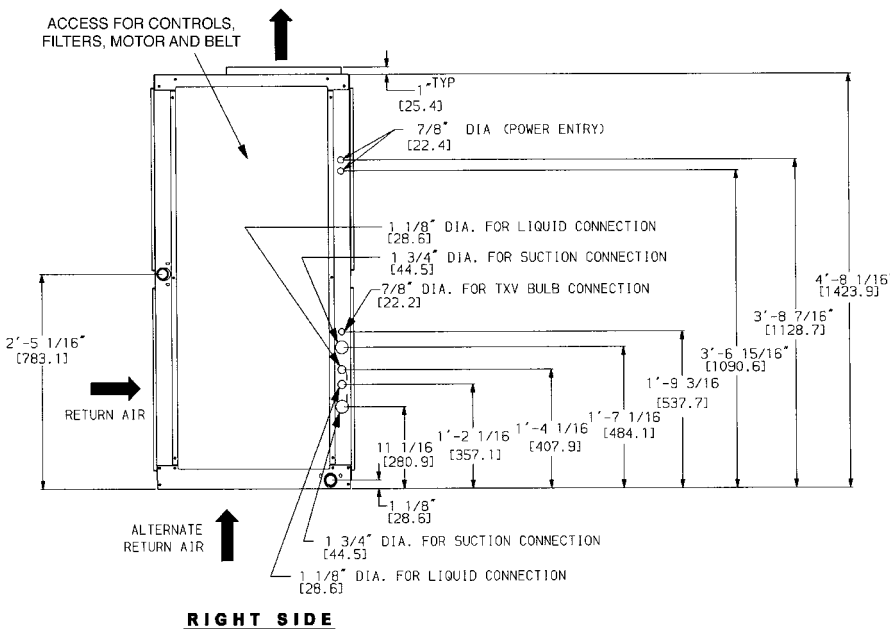
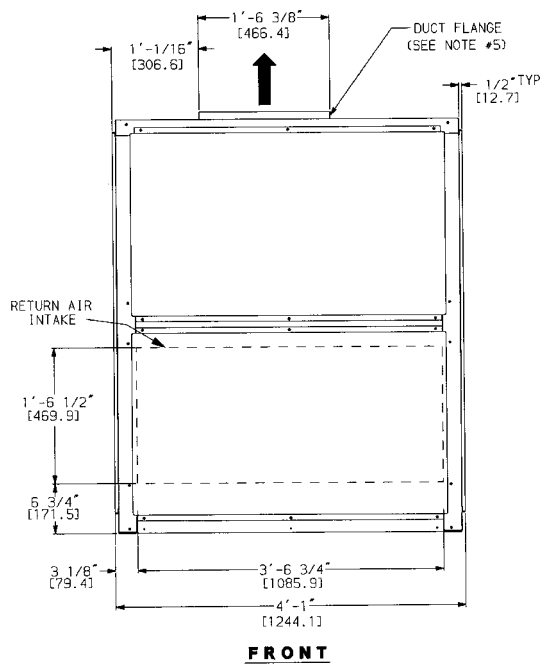
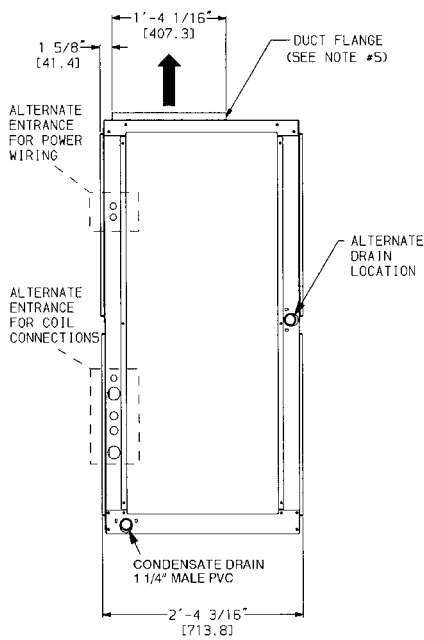
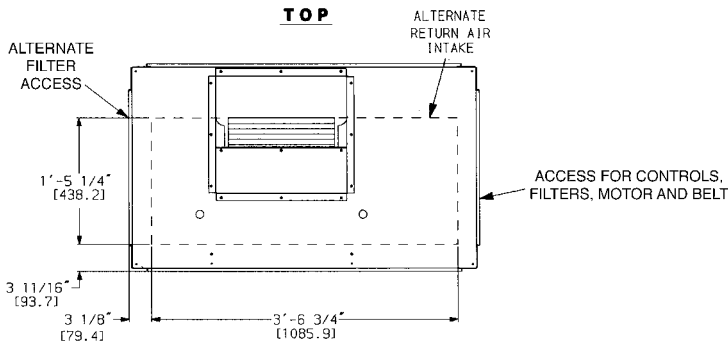

TXV - Thermostatic Expansion Valve

- NOTES:**
- Dimensions in [] are in millimeters.
 - ➡ Direction of air flow.
 - Recommended clearance:
 - Rear: 39(76.2 mm) (2869(762 mm) with electric heat accessory)
 - Front: 2869(762 mm)
 - Right side: 2869(762 mm)
 - Left Side: 2869(762 mm)
 - Local codes or jurisdiction may prevail.
 - Liquid piping not supplied by Carrier.
 - Duct flange is factory supplied and field installed.

40RM/RMS

Dimensions (cont)

40RM/RMS

40RM014SD-024SD
40RMS014SD-024SD

TOP

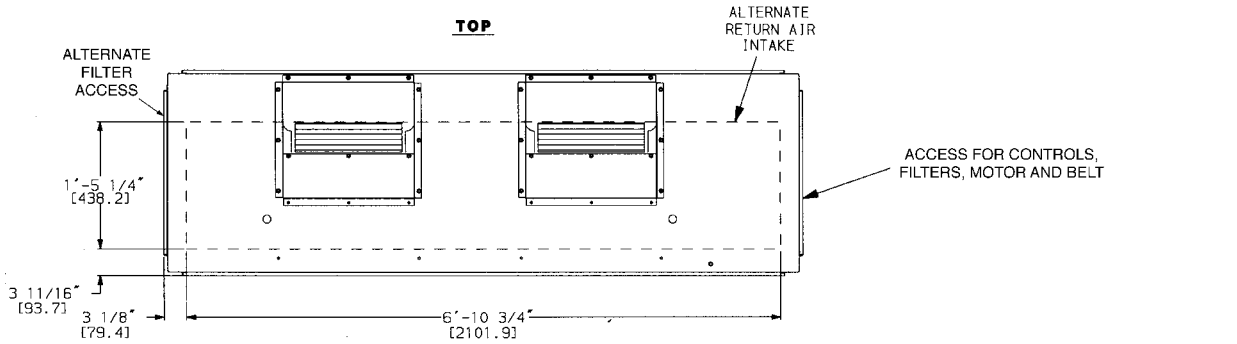

LEFT SIDE

FRONT

TXV - Thermostatic Expansion Valve

- NOTES:**
- Dimensions in [] are in millimeters.
 - Direction of airflow.
 - Recommended clearance:
 - Rear: 39 (76.2 mm) (2869 [762 mm] with electric heat accessory)
 - Front: 2869 (762 mm)
 - Right side: 2869 (762 mm)
 - Left Side: 2869 (762 mm)
 - Local codes or jurisdiction may prevail.
 - Liquid piping not supplied by Carrier.
 - Duct flange is factory supplied and field installed.

ACCESS FOR CONTROLS, FILTERS, MOTOR AND BELT

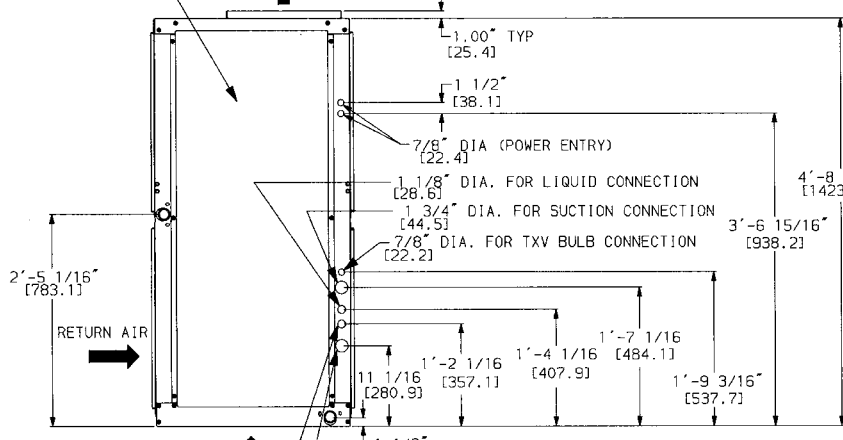

RIGHT SIDE

UNIT

UNIT	UNIT WEIGHT lb (kg)
40RM014SD	804 (364)
40RM016SD	819 (371)
40RM024SD	824 (373)
40RMS014SD	795 (360)
40RMS016SD	811 (367)
40RMS024SD	817 (370)

All the weights mentioned in the table are for double skin units.

40RM028SD,034SD
40RMS028SD,034SD

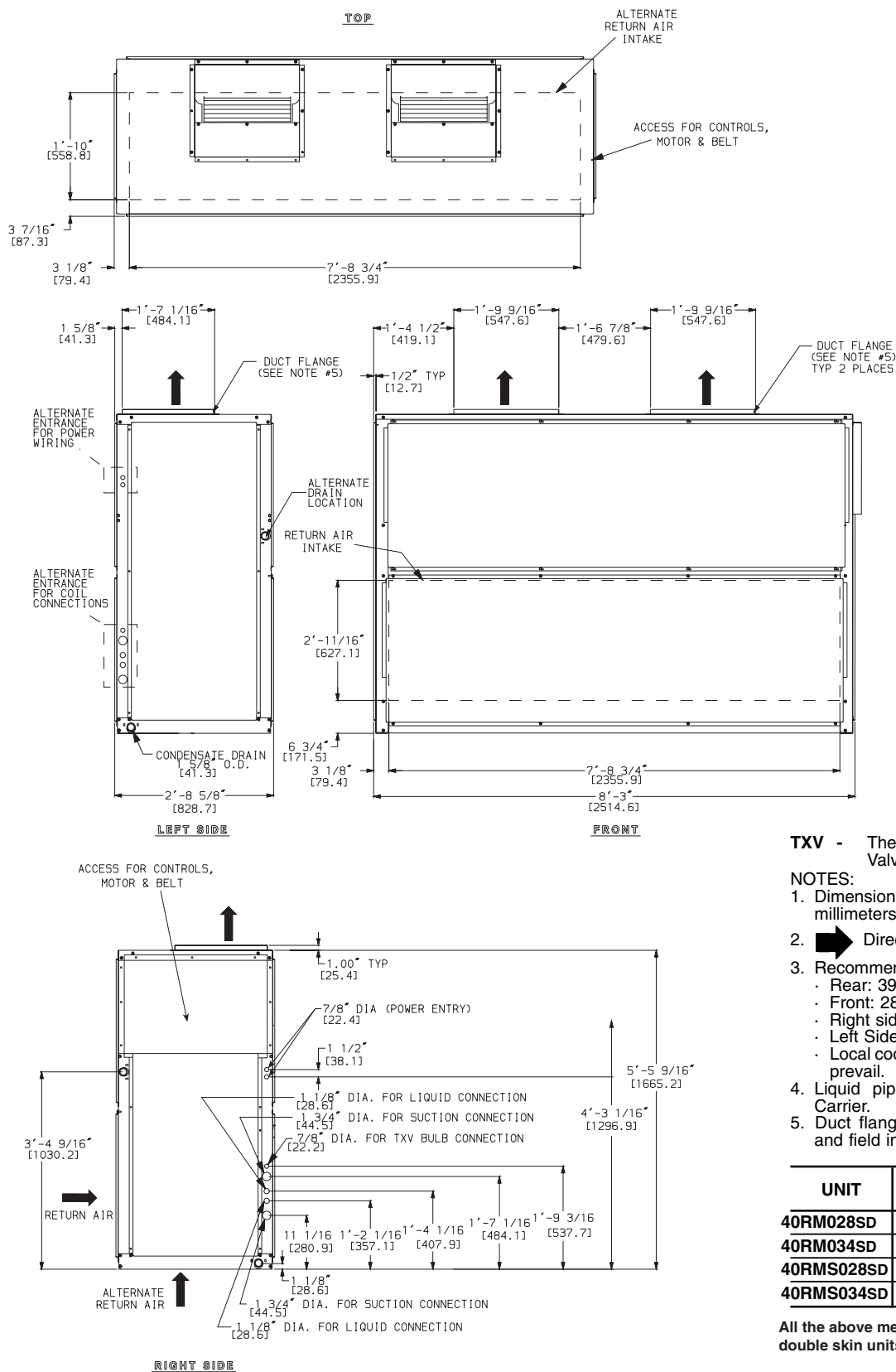

TXV - Thermostatic Expansion Valve

NOTES:

- Dimensions in [] are in millimeters.
- Direction of airflow.
- Recommended clearance:
 - Rear: 39 (76.2 mm)
 - Front: 28-69 (762 mm)
 - Right side: 28-69 (762 mm)
 - Left Side: 28-69 (762 mm)
 - Local codes or jurisdiction may prevail.
- Liquid piping not supplied by Carrier.
- Duct flange is factory supplied and field installed.

UNIT	UNIT WEIGHT lb (kg)
40RM028SD	1188 (538)
40RM034SD	1198 (542)
40RMS028SD	1203 (544)
40RMS034SD	1210 (548)

All the above mentioned weights are for double skin units.

40RM/RMS

Dimensions (cont)

40RM/RMS

OVERHEAD SUSPENSION ACCESSORY

UNIT SIZES 007-012

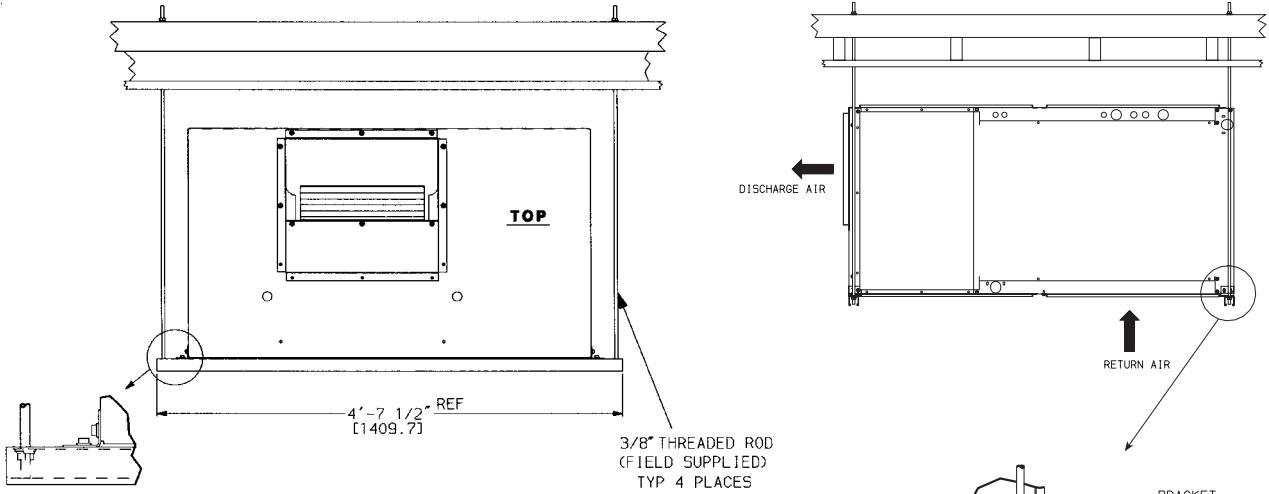

UNIT SIZES 014-024

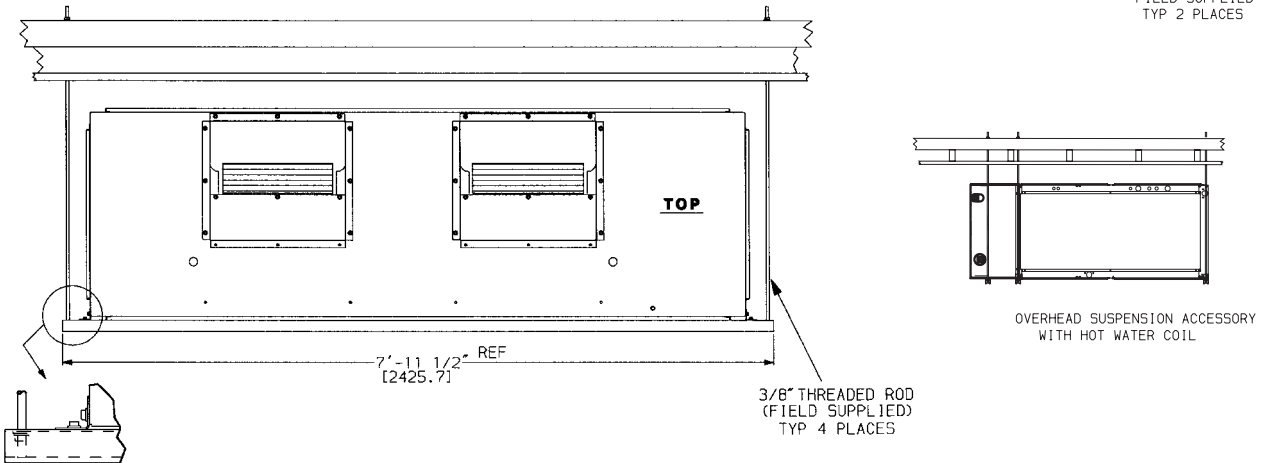

UNIT SIZES 028,034

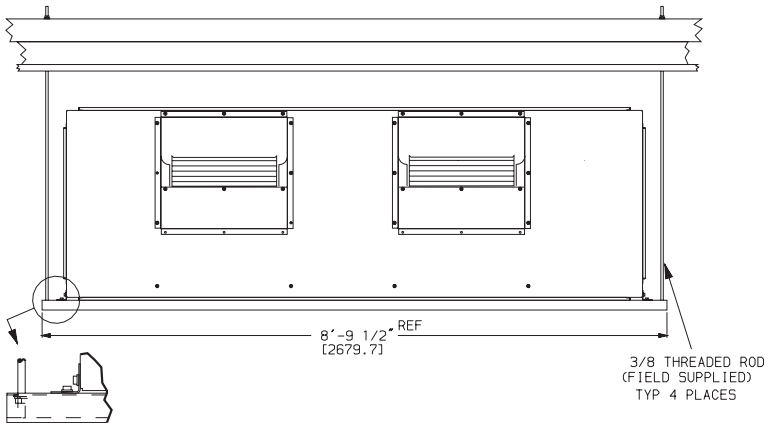

NOTE: Dimensions in [] are millimeters.

PLENUM, RETURN-AIR GRILLE, AND SUBBASE ACCESSORIES

UNIT SIZES 007-012

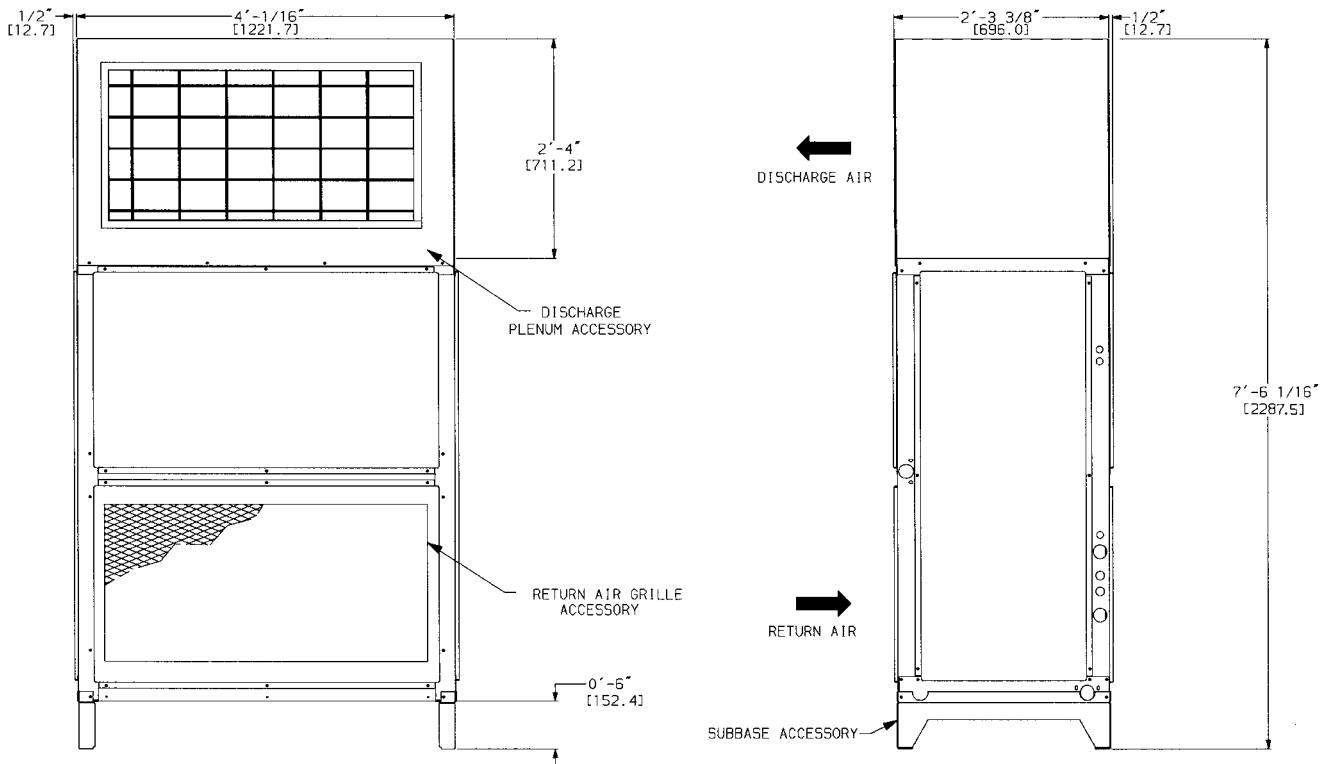

UNIT SIZES 014-024

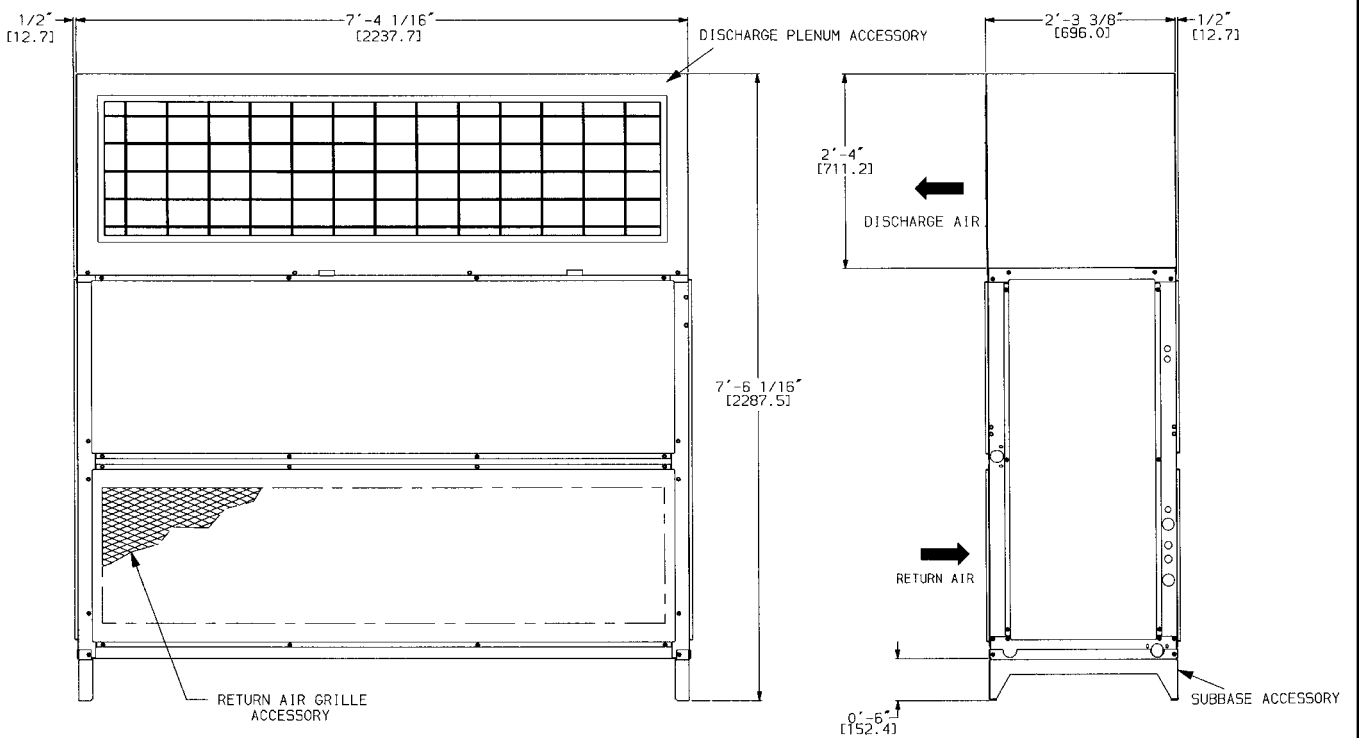

NOTE: Dimensions in [] are millimeters.

40RM/RMS

Dimensions (cont)

PLENUM, RETURN-AIR GRILLE, AND SUBBASE ACCESSORIES (cont)

UNIT SIZES 028,034

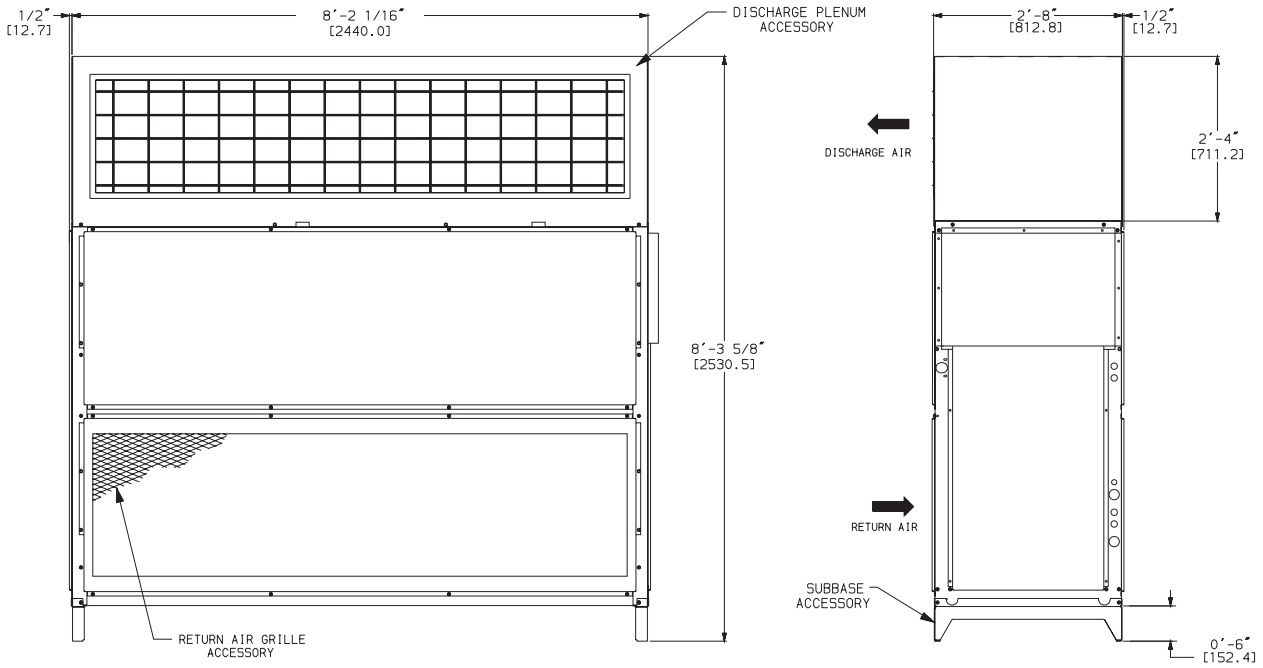

NOTE: Dimensions in [] are millimeters.

40RM/RMS

HOT WATER AND STEAM COIL ACCESSORIES

UNIT SIZES 007-012

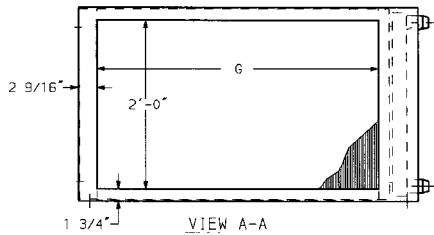
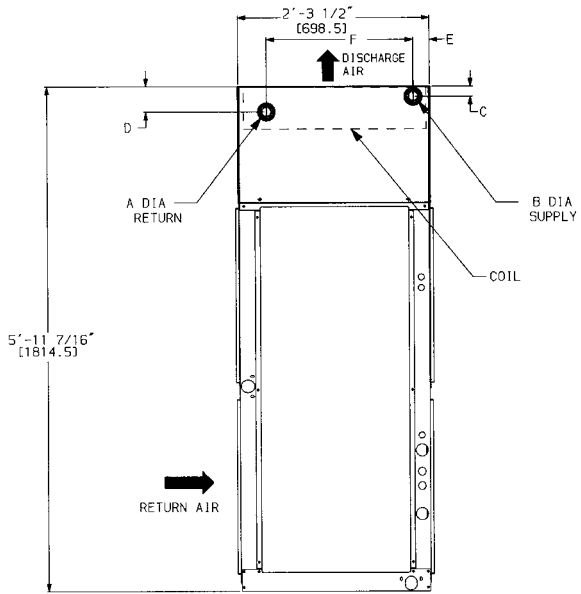
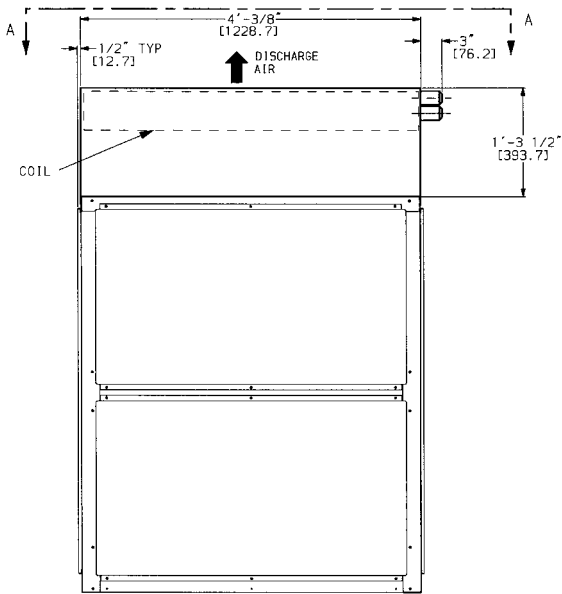

NOTE: Dimensions in [] are millimeters.

DIMENSION	HOT WATER COIL	STEAM COIL
A	1 1/2" MPT [38.1]	1 1/2" MPT [38.1]
B	1 1/2" MPT [38.1]	2 1/2" MPT [63.5]
C	2 3/8" [60.3]	3 1/8" [79.4]
D	4 7/8" [123.8]	3 1/8" [79.4]
E	2 1/8" [54.0]	4 9/16" [115.8]
F	1'-11 1/4" [590.6]	1'-9" [584.2]
G	3'- 4" [1016.0]	3'-4" [1016.0]

UNIT SIZES 014-024

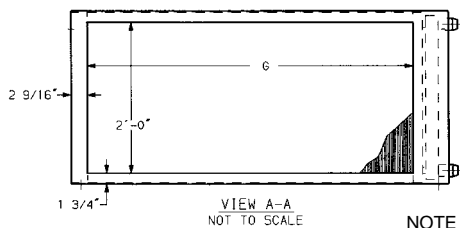
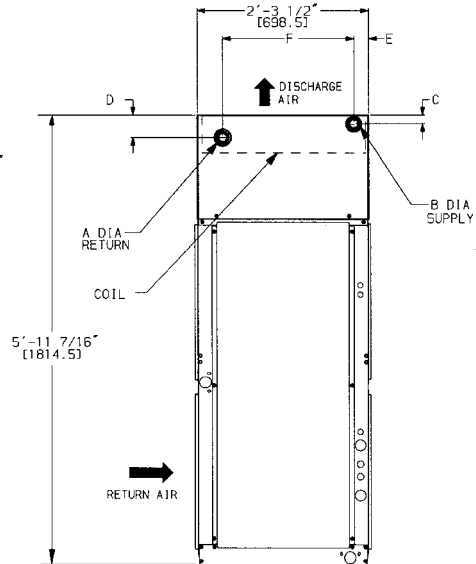
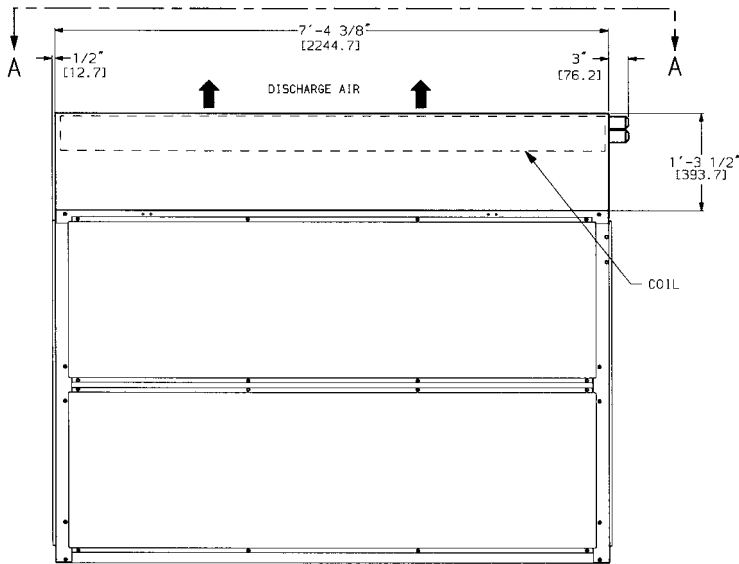

VIEW A-A
NOT TO SCALE

NOTE : Dimensions in [] are millimeters.

DIMENSION	HOT WATER COIL	STEAM COIL
A	2" MPT [50.8]	1 1/2" MPT [38.1]
B	2" MPT [50.8]	2 1/2" MPT [63.5]
C	2 3/8" [60.3]	3 1/8" [79.4]
D	4 7/8" [123.8]	3 1/8" [79.4]
E	2 1/8" [54.0]	4 9/16" [115.8]
F	1'-11 1/4" [590.6]	1'-9" [584.2]
G	6'- 8" [2032.0]	6'-8" [2032.0]

40RM/RMS

Dimensions (cont)

HOT WATER AND STEAM COIL ACCESSORIES (cont) UNIT SIZES 028,034

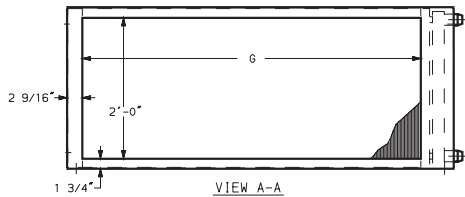
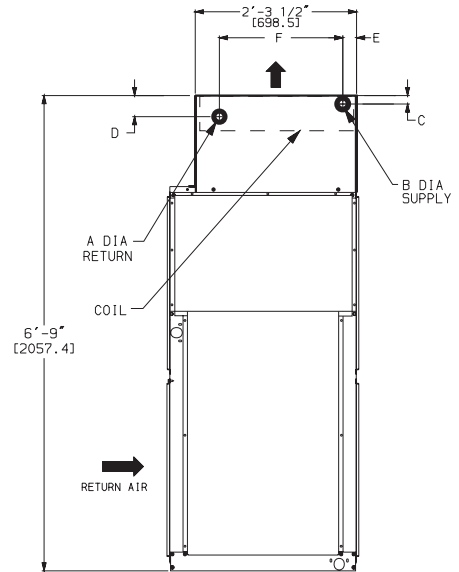
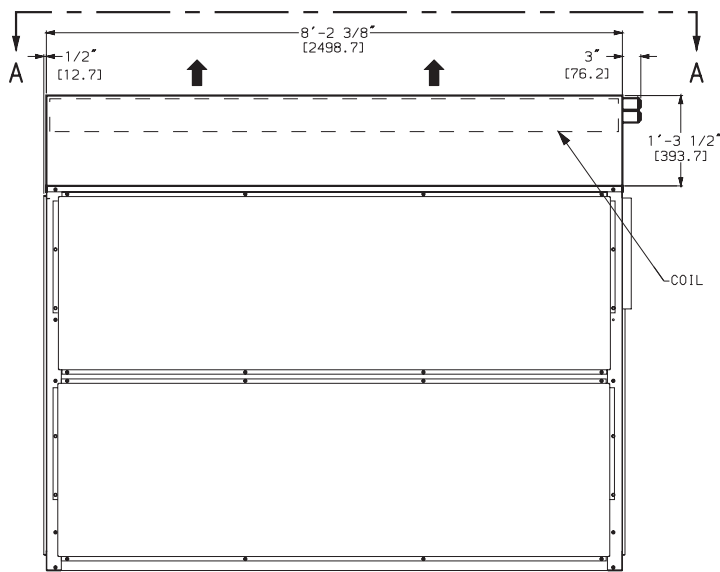

NOTE: Dimensions in [] are millimeters.

DIMENSION	HOT WATER COIL	STEAM COIL
A	2" MPT [50.8]	1½" MPT [38.1]
B	2" MPT [50.8]	2½" MPT [63.5]
C	2⅜" [60.3]	3⅞" [79.4]
D	4⅞" [123.8]	3⅞" [79.4]
E	2⅛" [54.0]	4⅞" [115.8]
F	1'-11¼" [590.6]	1'-9" [584.2]
G	7'-6" [2286.0]	7'-6" [2286.0]

ECONOMIZER ACCESSORY

UNIT SIZES 007-012

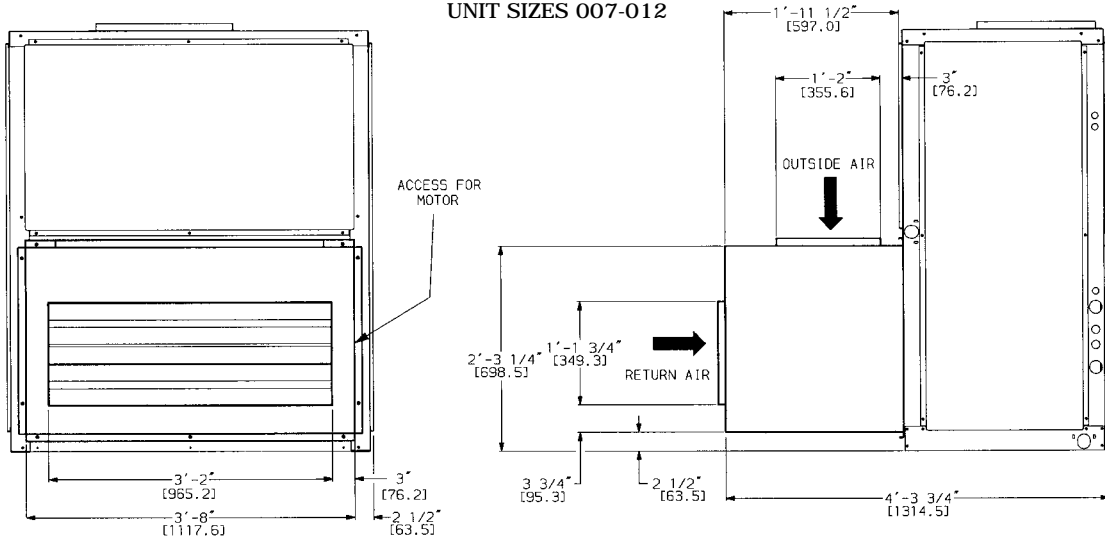

UNIT SIZES 014-024

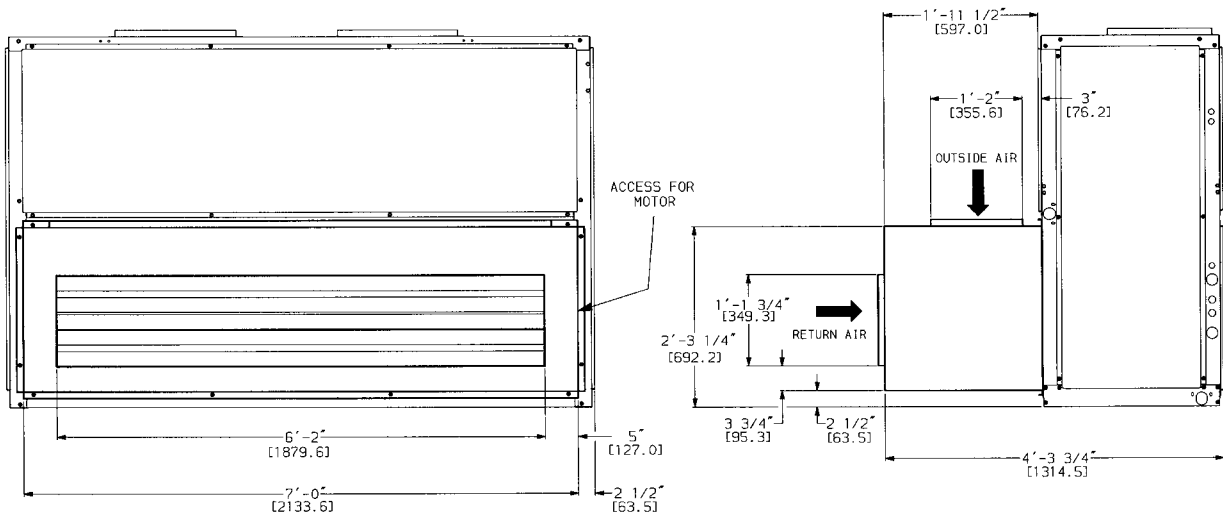

UNIT SIZES 028,034

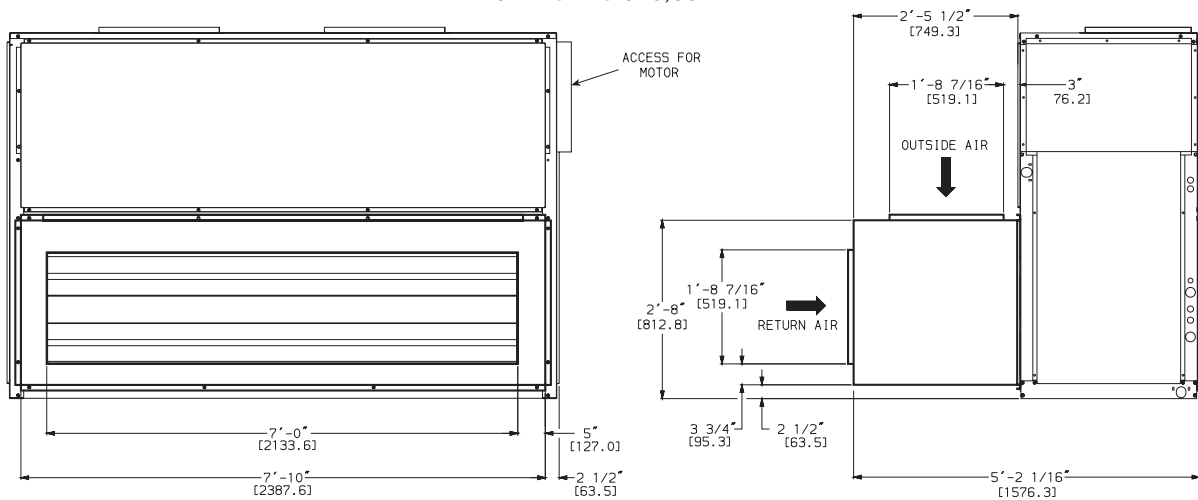

NOTES:

1. For horizontal unit applications, economizer can be attached to end of unit opposite duct connections.
2. Dimensions in [] are millimeters.

Dimensions (cont)

40RM/RMS

ELECTRIC HEAT ACCESSORY UNIT SIZES 007-012

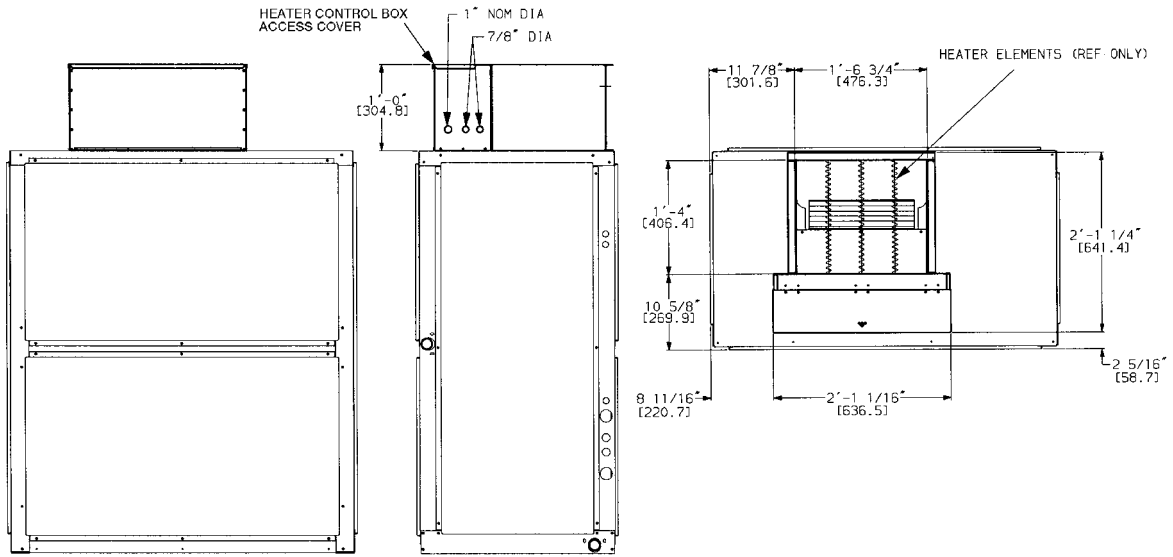

UNIT SIZES 014-034

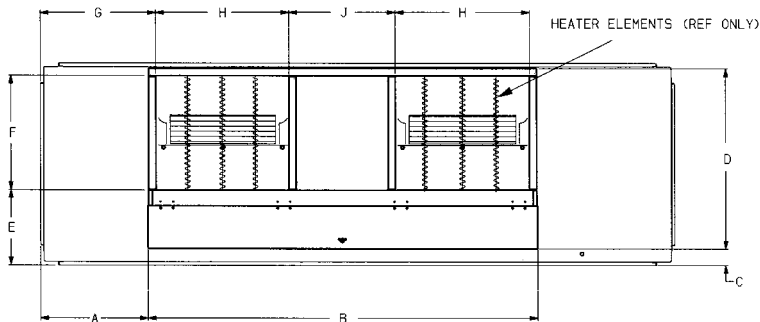
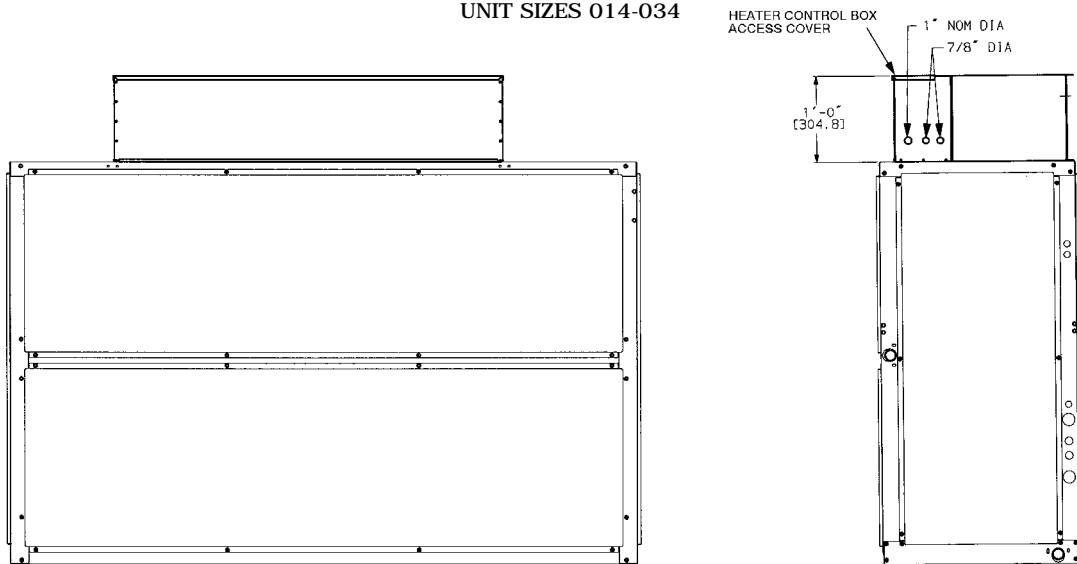

UNIT SIZE	A	B	C	D	E	F	G	H	J
014-024	1'-3 1/4" [387.4]	4'-6 3/8" [1381.1]	2 5/16" [58.7]	2'-1 1/4" [641.4]	10 9/16" [269.9]	1'-4" [406.4]	1'-4 5/16" [414.3]	1'-6 3/4" [476.3]	1'-7 7/8" [327.0]
028,034	1'-3 3/8" [390.5]	5'-4 7/16" [1636.8]	2 1/16" [26.9]	2'-6 3/16" [766.8]	1'-1/4" [311.2]	1'-7" [482.6]	1'-4 5/16" [414.0]	1'-10" [558.8]	1'-4 7/16" [417.1]

NOTE: Dimensions in [] are millimeters.

Selection procedure (with example) — English (60 Hz)

Cooling (DX)

- I Determine the cooling load and temperature and quantity of air entering the evaporator.

Given:

Total Capacity 200,000 Btuh
Sensible Heat Capacity..... 130,000 Btuh
Air Temperature Entering Indoor
Coil 80 F db, 67 F wb
Air Quantity Entering Indoor Coil 6000 cfm
Ductwork Static Pressure Loss 0.8 in. wg
Power Supply 230-3-60

- II Determine unit selection and coil refrigerant temperature.

Enter the Cooling Capacities table at 6000 cfm. Select a 40RM016 unit which has a total capacity of 207,000 and 174,000 Btuh at 40 and 45 F coil refrigerant temperature, respectively. By interpolation, coil refrigerant temperature of 41.1 F is needed to give a total capacity of 200,000 Btuh. Sensible capacity is approximately 149,000 Btuh. Cooling load is satisfied.

Heating (Hot Water Coil)

- I Determine heating load and temperature of air entering the indoor coil.

Given:

Load..... 425,000 Btuh
Entering-Air Temperature 70 F
Coils..... 2-Row Hot Water
Coil Entering-Water Temperature 200 F
Water Temperature Drop 20 F

- II Find the heating capacity.

Enter Hydronic Heating Capacities table for the 40RM016 unit at 6000 cfm. A 2-row hot water coil delivers 471,000 Btuh (based on 60 F entering air temperature and 20 F water temperature drop). Since existing entering air temperature is 70 F, enter the Heating Correction Factors table for hot water coils at 200 F entering water temperature, 20 F water temperature drop and 70 F entering air. Read a constant of 0.93.

$$471,000 \times 0.93 = 438,000$$

The 438,000 Btuh rating satisfies the heating load.

Fan

- I Determine fan speed and brake horsepower:

From the Accessory Pressure Drop table, read a loss of 0.23 in. wg for a hot water coil at 6000 cfm.

$$\begin{aligned} \text{External static pressure} &= 0.80 + 0.23 \\ &= 1.03 \text{ in. wg} \end{aligned}$$

Enter 40RM016 Fan Performance table at 6000 cfm and 1.03 in. wg. Interpolate and determine fan speed of 866 rpm and 2.7 bhp.

- II Determine motor and drive.

Enter the fan motor data tables on page 52, and find that the 230 v standard motor for a 40RM016 unit is rated at 3.7 Hp. Since the bhp required is 2.7, a standard motor satisfies the requirement and should be used.

Next, find the type of drive that satisfies the 866 rpm requirement in the Drive Data tables on pages 54-59. For a 40RM016 unit, the Medium-Static Drive table on page 54 shows an rpm range of 742 to 943. Since the rpm required is 866, the medium-static drive satisfies the requirement and should be used. Select the standard motor and medium-static drive combination (option code HC or FD).

To select an outdoor unit for this 40RM016 indoor section, refer to the Combination Rating sheets for Carrier condensing units in the condensing unit Product Data Digest, or consult the Carrier Electronic Catalog.

Cooling (Chilled Water)

NOTE: Chilled water coils (40RMS) can be selected by using Carrier's Electronic Catalog software program.

40RM/RMS

Selection procedure (with example) — SI (50 Hz)

Cooling (DX)

I Determine the cooling load and temperature and quantity of air entering the evaporator.

Given:

Total Capacity 37 kW
Sensible Heat Capacity 29 kW
Air Temp Entering
Indoor Coil 26.7 C db, 19 C wb
Air Quantity Entering Indoor Coil 1900 L/s
Ductwork Static Pressure Loss 200 Pa

II Determine unit selection and coil refrigerant temperature.

Enter the Cooling Capacities table at 1900 L/s. Select a 40RM012 unit which has a total capacity of 37.35 kW at 6 C coil refrigerant temperature. Sensible capacity is 29.61 kW. Cooling load is satisfied.

Heating (Hot Water Coil)

I Determine heating load and temperature of air entering the indoor coil.

Given:

Load 85 kW
Entering-Air Temperature 15.6 C
Coils 2-Row Hot Water
Coil Entering-Water Temperature 93.3 C
Water Temperature Drop 11.1 C

II Find the heating capacity.

Enter Hydronic Heating Capacities table for the 40RM012 unit at 1900 L/s. A 2-row hot water coil delivers 90 kW (based on 15.6 C entering air temperature and 11.1 C water temperature drop).

The 90 kW rating satisfies the heating load.

Fan

I Determine fan speed and brake horsepower.

From the Accessory Pressure Drop table, read a loss of 93 Pa for a hot water coil at 1900 L/s.

$$\begin{aligned}\text{External static pressure} &= 200 + 93 \\ &= 293 \text{ Pa}\end{aligned}$$

Enter 40RM012 Fan Performance table at 1900 L/s and 293 Pa. Interpolate and determine fan speed of 15.79 r/s and 1.41 kW.

II Determine motor and drive.

Enter the Fan Motor Data tables on page 52, and find that the standard motor for a 40RM012 unit is rated at 2.16 kW. Since the kW required is 1.41, a standard motor satisfies the requirement and should be used.

Next, find the type of drive that satisfies the 15.79 r/s requirement in the Drive Data tables on page 54-59. For a 40RM012 unit, the Medium-Static Drive table on page 59 shows an r/s range of 13.5 to 17.4. Since the r/s required is 15.79, the medium-static drive satisfies the requirement and should be used. Select the standard motor and medium-static drive combination (option code HC or FD).

To select an outdoor unit for this 40RM012 indoor section, refer to the Combination Rating sheets for Carrier condensing units in the condensing unit Product Data Digest, or consult the latest Carrier Electronic Catalog.

Cooling (Chilled Water)

NOTE: Select chilled water coils (40RMS) by using Carrier's Electronic Catalog software program.

Performance data

40RM COOLING CAPACITIES — ENGLISH

UNIT 40RM	EVAPORATOR AIR		COIL REFRIGERANT TEMP (F)									
	Airflow (Cfm) BF	Ewb (F)	30		35		40		45		50	
			TC	SHC	TC	SHC	TC	SHC	TC	SHC	TC	SHC
007	1,800 0.06	72	116	55	104	50	93	46	79	40	64	35
		67	96	61	85	56	74	50	61	45	47	40
		62	80	66	69	61	57	55	46	46	39	39
	2,400 0.10	72	135	65	121	60	108	54	92	48	75	42
		67	112	73	99	68	86	62	71	56	55	49
		62	94	81	81	75	67	67	56	56	47	47
	3,000 0.12	72	150	73	135	68	120	62	102	56	83	49
		67	125	85	112	78	96	71	80	65	61	57
		62	105	95	90	86	75	75	64	64	54	54
008	2,250 0.06	72	144	69	130	63	116	57	99	50	80	43
		67	120	76	106	70	92	63	76	56	59	50
		62	100	83	87	76	71	69	57	57	49	49
	3,000 0.10	72	169	81	151	75	135	68	114	61	94	53
		67	140	92	124	85	108	77	89	69	69	62
		62	118	101	102	94	84	84	70	70	59	59
	3,750 0.12	72	187	92	168	85	150	78	127	70	104	61
		67	157	106	140	97	120	89	100	81	77	72
		62	132	118	112	108	94	94	80	80	68	68
012	3,000 0.05	72	193	92	174	81	154	76	132	67	108	58
		67	161	102	143	93	123	85	102	76	79	67
		62	134	111	116	102	96	93	78	78	66	66
	4,000 0.07	72	223	108	201	99	179	91	153	81	125	71
		67	186	122	166	113	143	104	119	93	92	82
		62	157	136	136	126	113	113	95	95	80	80
	5,000 0.12	72	246	122	222	112	198	103	169	93	138	81
		67	207	140	185	131	159	120	132	109	102	97
		62	175	159	149	145	126	126	109	109	92	92
014	3,750 0.06	72	223	107	204	99	183	91	157	81	127	70
		67	188	121	169	112	144	102	118	90	94	81
		62	154	133	136	123	114	111	94	94	80	80
	5,000 0.08	72	259	126	234	117	210	108	180	97	145	85
		67	220	146	194	136	166	124	138	112	110	100
		62	178	163	156	150	134	134	114	114	97	97
	6,250 0.10	72	284	142	257	132	230	122	198	111	160	98
		67	242	166	209	154	183	145	153	131	119	117
		62	197	188	172	172	150	150	130	130	111	111
016	4,500 0.03	72	282	134	254	123	228	112	194	100	162	89
		67	233	149	209	138	178	125	149	112	117	99
		62	192	163	169	151	141	138	116	116	98	98
	6,000 0.05	72	320	156	293	145	263	134	223	119	179	104
		67	276	181	243	167	207	153	174	137	137	123
		62	225	200	198	185	167	167	140	140	119	119
	7,500 0.08	72	358	177	319	163	290	152	248	137	197	120
		67	305	208	263	192	229	178	193	160	153	144
		62	251	232	218	215	188	188	161	161	136	136
024	6,000 0.03	72	365	174	330	161	296	147	254	131	206	114
		67	309	198	274	182	234	166	195	150	153	132
		62	250	216	221	200	186	182	155	155	132	132
	8,000 0.06	72	416	203	378	189	338	174	291	157	235	138
		67	354	237	305	217	269	202	224	183	179	163
		62	290	264	253	245	218	218	187	187	159	159
	10,000 0.07	72	454	228	413	213	373	198	319	179	259	160
		67	376	266	338	251	296	235	250	214	194	189
		62	316	303	279	278	244	244	213	213	182	182

40RM/RMS

Performance data (cont)

40RM COOLING CAPACITIES — ENGLISH (cont)

UNIT 40RM	EVAPORATOR AIR		COIL REFRIGERANT TEMP (F)									
	Airflow (Cfm) BF	Ewb (F)	30		35		40		45		50	
			TC	SHC	TC	SHC	TC	SHC	TC	SHC	TC	SHC
028	7,500 0.04	72	440	211	394	193	361	180	312	162	255	142
		67	374	241	385	225	287	205	235	184	191	166
		62	303	265	270	247	229	226	193	193	165	165
	10,000 0.06	72	498	246	454	229	408	212	354	193	288	170
		67	425	288	373	267	327	249	271	226	220	203
		62	350	325	306	302	267	267	232	232	199	199
	12,500 0.08	72	—	—	495	258	445	240	385	220	318	198
		67	456	327	408	308	359	289	304	265	239	235
		62	380	375	336	336	299	299	264	264	226	226
034	9,000 0.04	72	527	253	473	232	433	216	375	194	306	170
		67	449	290	402	270	345	246	282	221	229	199
		62	364	318	323	297	275	271	232	232	198	198
	12,000 0.06	72	598	295	545	275	490	254	425	232	346	205
		67	510	346	448	321	393	298	326	271	263	244
		62	420	390	367	362	321	321	279	279	238	238
	15,000 0.08	72	—	—	594	309	534	288	462	264	382	237
		67	547	392	490	370	431	347	365	318	287	282
		62	456	450	403	403	359	359	317	317	271	271

LEGEND

- BF — Bypass Factor
- db — Dry-Bulb Temp (F)
- Ewb — Entering Wet-Bulb Temp (F)
- lwb — Leaving Wet-Bulb Temp (F)
- SHC — Sensible Heat Capacity (1000 Btuh)
- TC — Total Capacity (1000 Btuh)

NOTES:

1. Direct interpolation is permissible. Do not extrapolate.
2. Evaporator fan heat not deducted from ratings.
3. Ratings based on approximately 15 F superheat leaving coil.
4. Dashes indicate coil loading limits are exceeded.
5. Formulas:

$$\text{Leaving db} = \text{entering db} - \frac{\text{sensible heat capacity (Btuh)}}{1.1 \times \text{cfm}}$$

$$\text{Leaving wb} = \text{wet-bulb temperature corresponding to enthalpy of air leaving coil (h}_{lwb}\text{)}$$

$$h_{lwb} = h_{ewb} - \frac{\text{total capacity (Btuh)}}{4.5 \times \text{cfm}}$$

where h_{ewb} = enthalpy of air entering coil

6. SHC is based on 80 F db temperature of air entering evaporator coil. Below 80 F db, subtract (corr factor x cfm) from SHC. Above 80 F db, add (corr factor x cfm) to SHC. See *italic type below*.

BYPASS FACTOR	ENTERING AIR DRY-BULB TEMP (F)					
	79	78	77	76	75	Under 75
	<i>81</i>	<i>82</i>	<i>83</i>	<i>84</i>	<i>85</i>	<i>Over 85</i>
	Correction Factor					
0.02	1.08	2.16	3.23	4.31	5.39	use formula shown below
0.05	1.05	2.09	3.14	4.18	5.23	
0.10	0.99	1.98	2.97	3.96	4.95	
0.15	0.94	1.87	2.81	3.74	4.68	
0.20	0.88	1.76	2.64	3.52	4.40	
0.25	0.83	1.65	2.48	3.30	4.13	
0.30	0.77	1.54	2.31	3.08	3.85	

Interpolation is permissible.

$$\text{Correction Factor} = 1.1 \times (1 - \text{BF}) \times (\text{db} - 80)$$

Performance data (cont)

40RM COOLING CAPACITIES — SI (cont)

UNIT 40RM	EVAPORATOR AIR		COIL REFRIGERANT TEMP (C)													
	Airflow (L/s) BF	Ewb (C)	-1		0		2		4		6		8		10	
			TC	SHC	TC	SHC	TC	SHC	TC	SHC	TC	SHC	TC	SHC	TC	SHC
028	3500 .04	22	125.95	61.58	121.69	59.95	113.17	56.69	104.65	53.45	96.11	50.22	87.57	47.04	79.02	43.94
		19	131.38	73.49	123.70	71.33	108.30	67.03	92.87	62.76	77.40	58.55	61.89	54.43	46.34	46.34
		16	86.95	83.51	83.12	80.66	75.43	74.98	67.71	67.71	59.95	59.95	52.17	52.17	44.34	44.34
	4700 .06	22	146.03	72.86	140.80	70.97	130.35	67.19	119.89	63.44	109.43	59.71	98.98	56.05	88.52	52.56
		19	121.55	85.85	116.28	83.71	105.73	79.45	95.19	75.24	84.63	71.12	74.08	67.17	63.52	63.52
		16	97.09	97.09	93.33	93.33	85.80	85.80	78.27	78.27	70.74	70.74	63.20	63.20	55.66	55.66
	5900 .08	22	159.37	81.76	153.60	79.77	142.08	75.79	130.55	71.82	119.02	67.89	107.49	64.01	95.96	60.28
		19	131.94	98.52	126.54	96.29	115.74	91.83	104.94	87.43	94.14	83.12	83.34	78.97	72.54	72.54
		16	105.39	105.39	101.70	101.70	94.30	94.30	86.91	86.91	79.52	79.52	72.13	72.13	64.73	64.73
034	4250 .04	22	151.16	74.13	146.07	72.13	135.88	68.13	125.69	64.15	115.49	60.19	105.27	56.27	95.05	52.43
		19	132.16	88.16	126.02	85.58	113.73	80.44	101.41	75.33	89.07	70.27	76.70	65.32	64.29	60.59
		16	103.92	100.45	99.38	97.00	90.28	90.14	81.14	81.14	71.97	71.97	62.77	62.77	53.52	53.52
	5650 .06	22	175.30	87.47	169.02	85.21	156.48	80.70	143.93	76.21	131.38	71.76	118.83	67.38	106.28	63.19
		19	145.93	103.33	139.63	100.72	127.01	95.52	114.39	90.38	101.76	85.34	89.14	80.49	76.50	76.18
		16	116.36	116.36	111.88	111.88	102.92	102.92	93.96	93.96	85.00	85.00	76.03	76.03	67.06	67.06
	7050 .08	22	191.24	97.85	184.33	95.48	170.49	90.77	156.66	86.08	142.82	81.42	128.99	76.84	115.15	72.42
		19	158.48	118.39	151.99	115.68	139.01	110.30	126.02	104.97	113.04	99.75	100.05	94.74	87.07	87.07
		16	126.37	126.37	121.95	121.95	113.12	113.12	104.29	104.29	95.45	95.45	86.62	86.62	77.78	77.78

LEGEND

BF — Bypass Factor
Edb — Entering Dry Bulb
Ewb — Entering Wet Bulb
Ldb — Leaving Dry Bulb
Lwb — Leaving Wet Bulb
SHC — Sensible Heating Capacity (kW)
TC — Total Capacity (kW)

NOTES:

- Ratings based on approximately 8.3 C superheat leaving coil.
- Direct interpolation is permissible. Do not extrapolate.
- The SHC is based on 26.7 C db temperature of air entering the unit. At any other temperature, correct the SHC reading from the table of cooling capacities as follows:
 Correction factor = $1.23 \times 10^{-3} \times (1 - BF) \times (db - 26.7)$
 Above 26.7 C, add SHC correction to SHC. Below 26.7 C, subtract SHC correction from SHC.

- Gross capacities shown do not include a deduction for evaporator-fan motor heat.
- Formulas (cooling):

$$t_{db} = t_{edb} - \frac{\text{sensible heat capacity (kW)}}{1.23 \times 10^{-3} \times (L/s)}$$

t_{lwb} = wet-bulb temperature corresponding to enthalpy of air leaving coil (h_{lwb})

$$h_{lwb} = h_{ewb} - \frac{\text{total capacity (kW)}}{1.20 \times 10^{-3} \times (L/s)}$$

where h_{ewb} = enthalpy of air entering coil (kJ/kg)

HYDRONIC HEATING CAPACITIES — ENGLISH

UNIT	AIRFLOW (Cfm)	1-ROW STEAM*		2-ROW HOT WATER COIL†			
		Cap.	Ldb	Cap.	Ldb	Water Flow (Gpm)	PD
40RM 007	1,800	146	134	156.0	140	15.6	3.4
	2,400	173	126	183.0	131	18.3	4.3
	3,000	209	123	206.0	124	20.6	5.2
40RM 40RMS 008	2,250	168	129	174.0	133	17.4	4.0
	3,000	209	123	206.0	124	20.6	5.2
	3,750	240	117	238.0	118	23.8	6.5
40RMS 010	2,550	183	125	199.0	132	19.9	4.5
	3,400	229	121	233.0	123	23.3	5.7
	4,250	254	114	271.0	119	27.1	7.2
40RM 40RMS 012	3,000	209	123	299.0	152	29.9	5.0
	4,000	243	115	275.0	124	27.5	6.6
	5,000	279	111	316.0	119	31.6	8.2
40RM 40RMS 014	3,750	370	150	362.0	149	36.2	4.2
	5,000	425	137	409.0	136	40.9	5.1
	6,250	465	128	456.0	128	45.6	6.0
40RM 40RMS 016	4,500	402	141	412.0	145	41.2	4.5
	6,000	458	129	471.0	133	47.1	5.5
	7,500	479	118	529.0	125	52.9	6.6
40RM 40RMS 024	6,000	458	129	506.0	138	50.6	5.1
	8,000	487	115	584.0	128	58.4	6.3
	10,000	499	105	652.0	120	65.2	7.5
40RM 40RMS 028	7,500	511	122	649.0	140	64.9	5.7
	10,000	575	112	752.0	130	75.2	7.1
	12,500	626	106	842.0	122	84.2	8.5
40RM 40RMS 034	9,000	560	117	735.0	136	73.5	6.2
	12,000	621	107	850.0	126	85.0	7.8
	15,000	670	101	950.0	119	95.0	9.3

LEGEND

Cap. — Capacity (Btuh in thousands)
 Ldb — Leaving-Air Dry-Bulb Temp (F)
 PD — Pressure Drop (ft water)

*Based on 5 psig steam, 60 F entering-air temperature. All steam coils are non-freeze type.
 †Based on 200 F entering water, 20 F water temperature drop, 60 F entering-air temperature.

NOTES:

- Maximum operating limits for heating coils: 175 psig at 400 F.
- Leaving db = ent db (F) + $\frac{\text{Capacity (Btuh)}}{1.1 \times \text{cfm}}$
- See Heating Correction Factors table.

HEATING CORRECTION FACTORS — ENGLISH

HOT WATER COIL						
Water Temp Drop (F)	Ent Water Temp (F)	Entering-Air Temp (F)				
		40	50	60	70	80
10	140	0.72	0.64	0.57	0.49	0.41
	160	0.89	0.81	0.74	0.66	0.58
	180	1.06	0.98	0.90	0.83	0.75
	200	1.22	1.15	1.07	1.00	0.92
	220	1.39	1.32	1.24	1.17	1.09
20	140	0.64	0.57	0.49	0.41	0.33
	160	0.81	0.74	0.66	0.58	0.51
	180	0.98	0.91	0.83	0.75	0.68
	200	1.15	1.08	1.00	0.93	0.85
	220	1.32	1.25	1.17	1.10	1.02
30	140	0.56	0.49	0.41	0.33	0.24
	160	0.74	0.66	0.58	0.51	0.43
	180	0.91	0.83	0.76	0.68	0.60
	200	1.08	1.00	0.93	0.85	0.78
	220	1.25	1.18	1.10	1.03	0.95

STEAM COIL					
Steam Pressure (psig)	Entering-Air Temp (F)				
	40	50	60	70	80
0	1.06	0.98	0.91	0.85	0.78
2	1.09	1.02	0.95	0.89	0.82
5	1.13	1.06	1.00	0.93	0.87

NOTE: Multiply capacity given in the Hydronic Heating Capacities table by the correction factor for conditions at which unit is actually operating. Correct leaving-air temperature using formula in Note 2 of Hydronic Heating Capacities table.

HYDRONIC HEATING CAPACITIES — SI

UNIT	AIRFLOW (L/s)	1-ROW STEAM*		2-ROW HOT WATER COIL†			
		Cap.	Ldb	Cap.	Ldb	Water Flow (L/s)	PD
40RM 007	850	43	57	46	59	1.0	10.2
	1150	53	53	53	53	1.2	12.8
	1450	62	51	61	50	1.3	16.0
40RM 40RMS 008	1000	48	55	50	56	1.1	11.5
	1400	59	50	60	50	1.3	15.3
	1800	71	47	70	47	1.5	19.5
40RMS 010	1200	54	52	58	55	1.3	13.4
	1600	64	48	69	50	1.5	17.3
	2000	74	46	79	48	1.7	21.4
40RM 40RMS 012	1450	62	50	88	65	1.9	15.0
	1900	72	46	90	54	2.0	24.7
	2350	82	44	93	48	2.0	24.5
40RM 40RMS 014	1750	108	66	106	65	2.3	12.4
	2350	122	58	120	57	2.6	15.2
	2950	136	53	134	52	2.9	17.9
40RM 40RMS 016	2100	117	61	120	62	2.6	13.3
	2800	129	53	137	55	3.0	16.2
	3500	140	48	154	51	3.3	19.5
40RM 40RMS 024	2900	135	53	150	58	3.3	15.6
	3800	140	46	170	52	3.7	18.6
	4700	146	41	191	49	4.1	22.3
40RM 40RMS 028	3500	149	50	189	60	4.1	16.9
	4700	166	44	218	53	4.7	20.8
	5900	183	41	247	50	5.4	25.4
40RM 40RMS 034	4250	164	47	215	57	4.7	18.5
	5650	180	41	247	51	5.4	22.8
	7050	196	38	278	48	6.0	27.7

LEGEND

Cap. — Capacity (kW)
 Ldb — Leaving-Air Dry-Bulb Temp (C)
 PD — Pressure Drop (kPa)

*Based on 34.5 kPag steam, 15.6 C entering-air temperature. All steam coils are non-freeze type.
 †Based on 93.3 C entering-water temperature, 11.1 C water temperature drop, 15.6 C entering-air temperature.

NOTES:

- Maximum operating limits for heating coils: 1207 kPag at 204.4 C.
- Leaving db = ent db (C) + $\frac{\text{Capacity (kW)}}{1.23 \times 10^{-3} \times \text{L/s}}$
- See Heating Correction Factors table.

HEATING CORRECTION FACTORS — SI

HOT WATER COIL						
Water Temp Drop (C)	Ent Water Temp (C)	Entering-Air Temp (C)				
		4	10	16	20	25
5	60	0.72	0.64	0.55	0.50	0.43
	70	0.87	0.79	0.71	0.65	0.58
	80	1.02	0.94	0.86	0.80	0.73
	90	1.17	1.09	1.01	0.95	0.89
	100	1.32	1.24	1.16	1.10	1.04
	11	60	0.65	0.56	0.48	0.42
70		0.80	0.72	0.63	0.58	0.51
80		0.95	0.87	0.79	0.73	0.66
90		1.10	1.02	0.94	0.89	0.82
100		1.26	1.18	1.09	1.04	0.97
16		60	0.56	0.48	0.39	0.33
	70	0.72	0.63	0.55	0.49	0.42
	80	0.87	0.79	0.70	0.65	0.58
	90	1.02	0.94	0.86	0.81	0.74
	100	1.18	1.10	1.02	0.97	0.90

STEAM COIL					
Steam Pressure (kPag)	Entering-Air Temp (C)				
	4	10	16	20	25
0	1.07	0.99	0.91	0.86	0.80
14	1.10	1.02	0.95	0.90	0.84
35	1.14	1.07	0.99	0.95	0.89

NOTE: Multiply capacity given in the Hydronic Heating Capacities table by the correction factor for conditions at which unit is actually operating. Correct leaving-air temperature using formula in Note 2 of Hydronic Heating Capacities table.

40RM/RMS

Performance data (cont)

FAN PERFORMANCE DATA — 0.0-1.2 in. wg ESP — 60 Hz, ENGLISH

UNIT	AIRFLOW (Cfm)	EXTERNAL STATIC PRESSURE (in. wg)													
		0.0		0.2		0.4		0.6		0.8		1.0		1.2	
		Rpm	Bhp	Rpm	Bhp	Rpm	Bhp	Rpm	Bhp	Rpm	Bhp	Rpm	Bhp	Rpm	Bhp
40RM 007	1,800	320	0.22	442	0.32	534	0.42	611	0.52	<u>678</u>	<u>0.61</u>	<u>739</u>	<u>0.70</u>	<u>795</u>	<u>0.80</u>
	2,100	373	0.31	483	0.42	569	0.53	642	0.63	<u>708</u>	<u>0.73</u>	<u>767</u>	<u>0.82</u>	<u>821</u>	<u>0.92</u>
	2,400	427	0.42	526	0.53	606	0.64	676	<u>0.75</u>	<u>739</u>	<u>0.86</u>	<u>796</u>	<u>0.96</u>	<u>849</u>	<u>1.06</u>
	2,700	480	0.54	570	0.67	<u>646</u>	<u>0.78</u>	<u>712</u>	<u>0.89</u>	<u>773</u>	<u>1.00</u>	<u>828</u>	<u>1.11</u>	<u>880</u>	<u>1.21</u>
	3,000	533	0.69	616	0.82	<u>687</u>	<u>0.94</u>	<u>750</u>	<u>1.05</u>	<u>808</u>	<u>1.16</u>	<u>862</u>	<u>1.28</u>	<u>912</u>	<u>1.39</u>
40RM 40RMS 008	2,250	359	0.32	472	0.44	560	0.55	634	0.65	700	0.75	<u>759</u>	<u>0.86</u>	814	0.96
	2,600	415	0.45	516	0.57	599	0.68	669	0.79	732	0.90	<u>790</u>	<u>1.01</u>	843	1.11
	3,000	478	0.62	569	0.75	645	0.86	712	0.98	<u>773</u>	<u>1.09</u>	<u>828</u>	<u>1.20</u>	879	<u>1.32</u>
	3,400	542	0.82	624	0.95	695	1.08	758	<u>1.20</u>	<u>815</u>	<u>1.31</u>	<u>869</u>	<u>1.43</u>	918	1.55
	3,750	598	1.03	673	1.17	<u>740</u>	<u>1.29</u>	<u>800</u>	<u>1.42</u>	<u>855</u>	<u>1.60</u>	<u>906</u>	<u>1.66</u>	954	<u>1.78</u>
40RMS 010	2,550	396	0.42	502	0.54	586	0.65	658	0.76	722	0.87	<u>780</u>	<u>0.97</u>	833	1.08
	2,975	462	0.60	556	0.72	634	0.84	701	0.95	<u>762</u>	<u>1.06</u>	<u>818</u>	<u>1.18</u>	870	<u>1.29</u>
	3,400	527	0.80	612	0.93	684	1.06	748	1.18	<u>806</u>	<u>1.30</u>	<u>860</u>	<u>1.41</u>	910	<u>1.53</u>
	3,825	593	1.05	670	1.18	737	1.31	<u>797</u>	<u>1.44</u>	<u>852</u>	<u>1.56</u>	<u>904</u>	<u>1.68</u>	<u>952</u>	<u>1.80</u>
	4,250	659	1.33	729	1.47	<u>791</u>	<u>1.60</u>	<u>848</u>	<u>1.73</u>	<u>901</u>	<u>1.86</u>	<u>950</u>	<u>1.98</u>	<u>997</u>	<u>2.11</u>
40RM 40RMS 012	3,000	444	0.58	541	0.71	621	0.83	691	0.94	753	1.05	809	1.17	<u>862</u>	<u>1.28</u>
	3,500	518	0.82	604	0.95	677	1.08	742	1.20	801	1.32	855	1.44	906	<u>1.56</u>
	4,000	592	1.11	669	1.25	736	1.38	797	1.51	853	1.63	<u>904</u>	<u>1.75</u>	<u>953</u>	<u>1.88</u>
	4,500	666	1.44	735	1.59	797	1.72	854	1.86	<u>907</u>	<u>1.99</u>	<u>956</u>	<u>2.12</u>	<u>1003</u>	<u>2.24</u>
	5,000	740	1.83	803	1.98	861	2.12	<u>914</u>	<u>2.26</u>	<u>964</u>	<u>2.39</u>	<u>1010</u>	<u>2.53</u>	<u>1055</u>	<u>2.66</u>
40RM 40RMS 014	3,750	363	0.37	475	0.58	566	0.80	645	1.02	715	1.24	<u>779</u>	<u>1.47</u>	839	1.69
	4,300	416	0.53	517	0.78	601	1.02	676	1.26	<u>743</u>	<u>1.50</u>	<u>805</u>	<u>1.74</u>	<u>862</u>	<u>1.99</u>
	5,000	484	0.81	573	1.08	650	1.35	719	1.62	<u>782</u>	<u>1.89</u>	<u>841</u>	<u>2.16</u>	<u>896</u>	<u>2.44</u>
	5,700	552	1.17	631	1.47	702	1.76	<u>766</u>	<u>2.06</u>	<u>826</u>	<u>2.36</u>	<u>881</u>	<u>2.66</u>	<u>934</u>	<u>2.96</u>
	6,250	605	1.51	678	1.83	<u>744</u>	<u>2.15</u>	<u>805</u>	<u>2.47</u>	<u>862</u>	<u>2.79</u>	<u>915</u>	<u>3.11</u>	<u>966</u>	<u>3.43</u>
40RM 40RMS 016	4,500	391	0.51	495	0.75	581	1.00	657	1.25	725	1.50	<u>787</u>	<u>1.76</u>	<u>845</u>	<u>2.02</u>
	5,300	460	0.80	551	1.08	629	1.35	700	1.63	<u>764</u>	<u>1.91</u>	<u>823</u>	<u>2.20</u>	<u>878</u>	<u>2.48</u>
	6,000	521	1.13	602	1.43	675	1.73	<u>741</u>	<u>2.04</u>	<u>801</u>	<u>2.34</u>	<u>858</u>	<u>2.65</u>	<u>911</u>	<u>2.96</u>
	6,800	590	1.60	663	1.93	<u>730</u>	<u>2.26</u>	<u>791</u>	<u>2.59</u>	<u>847</u>	<u>2.92</u>	<u>901</u>	<u>3.26</u>	<u>951</u>	<u>3.60</u>
	7,500	651	2.10	718	2.45	<u>779</u>	<u>2.81</u>	<u>837</u>	<u>3.16</u>	<u>890</u>	<u>3.52</u>	<u>941</u>	<u>3.88</u>	<u>990</u>	<u>4.24</u>
40RM 40RMS 024	6,000	503	1.07	587	1.37	661	1.67	727	1.97	789	2.28	846	2.59	900	2.90
	7,000	586	1.64	660	1.98	726	2.31	787	2.65	844	2.99	<u>898</u>	<u>3.33</u>	<u>948</u>	<u>3.67</u>
	8,000	670	2.37	735	2.74	795	3.12	851	3.49	<u>904</u>	<u>3.86</u>	<u>954</u>	<u>4.23</u>	<u>1001</u>	<u>4.61</u>
	9,000	754	3.28	812	3.69	867	4.09	918	4.50	<u>967</u>	<u>4.90</u>	<u>1014</u>	<u>5.31</u>	<u>1059</u>	<u>5.72</u>
	10,000	838	4.39	<u>891</u>	<u>4.83</u>	<u>941</u>	<u>5.27</u>	<u>988</u>	<u>5.70</u>	<u>1034</u>	<u>6.14</u>	<u>1077</u>	<u>6.85</u>	<u>1120</u>	<u>7.02</u>
40RM 40RMS 028	7,500	412	1.15	492	1.53	568	2.00	640	2.56	710	3.22	776	3.98	840	4.83
	8,750	481	1.76	550	2.17	616	2.66	680	3.22	742	3.86	802	4.58	<u>860</u>	<u>5.38</u>
	10,000	549	2.55	610	2.99	669	3.50	726	4.07	782	4.70	836	5.40	889	<u>6.17</u>
	11,250	618	3.52	672	4.00	725	4.53	777	5.12	827	5.76	<u>876</u>	<u>6.45</u>	<u>925</u>	<u>7.21</u>
	12,500	687	4.71	735	5.22	783	5.78	830	6.38	<u>876</u>	<u>7.04</u>	<u>922</u>	<u>7.74</u>	<u>966</u>	<u>8.49</u>
40RM 40RMS 034	9,000	471	1.78	539	2.17	604	2.63	667	3.17	728	3.78	788	4.46	<u>845</u>	<u>5.22</u>
	10,500	550	2.72	608	3.15	665	3.64	720	4.18	774	4.79	827	5.45	<u>878</u>	<u>6.18</u>
	12,000	628	3.93	679	4.40	730	4.92	779	5.48	827	6.09	<u>874</u>	<u>6.76</u>	<u>921</u>	<u>7.47</u>
	13,500	707	5.44	752	5.94	797	6.49	<u>841</u>	<u>7.08</u>	<u>885</u>	<u>7.71</u>	<u>928</u>	<u>8.38</u>	<u>970</u>	<u>9.10</u>
	15,000	785	7.27	826	7.81	<u>867</u>	<u>8.39</u>	<u>907</u>	<u>9.01</u>	<u>947</u>	<u>9.66</u>	<u>986</u>	<u>10.35</u>	<u>1024</u>	<u>11.07</u>

See Legend and Notes on page 32.

FAN PERFORMANCE DATA — 1.4-2.4 in. wg ESP — 60 Hz, ENGLISH

UNIT	AIRFLOW (Cfm)	EXTERNAL STATIC PRESSURE (in. wg)											
		1.4		1.6		1.8		2.0		2.2		2.4	
		Rpm	Bhp	Rpm	Bhp	Rpm	Bhp	Rpm	Bhp	Rpm	Bhp	Rpm	Bhp
40RM 007	1,800	847	0.89	896	0.98	942	1.07	986	1.16	1027	1.25	—	—
	2,100	872	1.02	920	1.11	965	1.21	1008	1.30	1050	1.40	—	—
	2,400	899	1.16	946	1.26	990	1.36	1033	1.46	1073	1.55	—	—
	2,700	928	1.32	974	1.42	1018	1.52	1059	1.63	1099	1.73	—	—
	3,000	959	1.49	1004	1.60	1046	1.71	1087	1.81	1126	1.92	—	—
40RM 40RMS 008	2,250	865	1.06	913	1.16	958	1.27	1001	1.37	1042	1.47	—	—
	2,600	893	1.22	940	1.33	984	1.43	1027	1.54	1067	1.65	—	—
	3,000	928	1.43	973	1.54	1017	1.65	1058	1.76	1098	1.87	—	—
	3,400	965	1.66	1010	1.78	1052	1.89	1092	2.00	1131	2.12	—	—
	3,750	1000	1.90	1043	2.02	1084	2.13	1124	2.25	1162	2.37	—	—
40RMS 010	2,550	884	1.18	931	1.29	975	1.40	1018	1.50	1059	1.61	—	—
	2,975	919	1.40	965	1.51	1009	1.62	1050	1.73	1090	1.84	—	—
	3,400	957	1.64	1002	1.76	1044	1.87	1085	1.98	1124	2.10	—	—
	3,825	998	1.92	1041	2.04	1082	2.16	1122	2.27	1160	2.39	—	—
	4,250	1041	2.23	1083	2.35	1123	2.48	1161	2.60	1199	2.72	—	—
40RM 40RMS 012	3,000	911	1.39	958	1.50	1002	1.61	1044	1.72	1084	1.83	1123	1.94
	3,500	953	1.67	998	1.79	1041	1.90	1082	2.02	1122	2.13	1159	2.25
	4,000	999	2.00	1042	2.12	1084	2.24	1124	2.36	1162	2.48	1199	2.60
	4,500	1047	2.37	1089	2.50	1129	2.62	1168	2.74	—	—	—	—
	5,000	1097	2.79	1138	2.92	1177	3.05	—	—	—	—	—	—
40RM 40RMS 014	3,750	894	1.91	947	2.14	996	2.37	1044	2.60	1089	2.83	—	—
	4,300	916	2.23	967	2.48	1016	2.73	1062	2.98	1107	3.24	—	—
	5,000	948	2.71	997	2.98	1044	3.26	1089	3.53	1133	3.81	—	—
	5,700	984	3.25	1031	3.55	1076	3.86	1120	4.16	1162	4.46	—	—
	6,250	1014	3.75	1060	4.07	1104	4.39	1147	4.71	1188	5.03	—	—
40RM 40RMS 016	4,500	899	2.29	951	2.56	999	2.84	1046	3.12	1091	3.41	1133	3.70
	5,300	930	2.78	980	3.08	1027	3.38	1072	3.68	1116	3.99	1157	4.30
	6,000	961	3.28	1009	3.60	1055	3.92	1098	4.24	1141	4.57	1181	4.91
	6,800	999	3.94	1045	4.28	1089	4.63	1132	4.98	1173	5.33	—	—
	7,500	1036	4.60	1080	4.97	1123	5.34	1164	5.71	—	—	—	—
40RM 40RMS 024	6,000	950	3.21	999	3.53	1045	3.85	1089	4.17	1131	4.50	1172	4.83
	7,000	996	4.02	1042	4.37	1086	4.72	1129	5.07	1169	5.43	—	—
	8,000	1047	4.99	1091	5.37	1133	5.75	1173	6.13	—	—	—	—
	9,000	1102	6.13	1143	6.54	1183	6.96	—	—	—	—	—	—
	10,000	1160	7.46	1200	7.91	—	—	—	—	—	—	—	—
40RM 40RMS 028	7,500	903	5.79	963	6.83	1021	7.98	1078	9.21	—	—	—	—
	8,750	917	6.26	972	7.22	1025	8.26	1078	9.38	—	—	—	—
	10,000	941	7.01	991	7.91	1040	8.89	1089	9.93	—	—	—	—
	11,250	972	8.02	1019	8.89	1064	9.83	—	—	—	—	—	—
	12,500	1010	9.29	1053	10.15	1095	11.05	—	—	—	—	—	—
40RM 40RMS 034	9,000	901	6.07	955	6.98	1008	7.98	1060	9.05	—	—	—	—
	10,500	928	6.98	978	7.84	1026	8.76	1073	9.74	—	—	—	—
	12,000	966	8.24	1011	9.07	1055	9.95	1098	10.88	—	—	—	—
	13,500	1011	9.86	1052	10.67	1092	11.52	—	—	—	—	—	—
	15,000	1062	11.84	—	—	—	—	—	—	—	—	—	—

40RM/RMS

See Legend and Notes on page 32.

Performance data (cont)

FAN PERFORMANCE DATA — 0.0-1.2 in. wg ESP — 50 HZ, ENGLISH

UNIT	AIRFLOW (Cfm)	EXTERNAL STATIC PRESSURE (in. wg)													
		0.0		0.2		0.4		0.6		0.8		1.0		1.2	
		Rpm	Bhp	Rpm	Bhp	Rpm	Bhp	Rpm	Bhp	Rpm	Bhp	Rpm	Bhp	Rpm	Bhp
40RM 007	1,800	320	0.22	442	0.32	534	0.42	611	0.52	678	0.61	739	0.70	795	0.80
	2,100	373	0.31	483	0.42	569	0.53	642	0.63	708	0.73	767	0.82	821	0.92
	2,400	427	0.42	526	0.53	606	0.64	676	0.75	739	0.86	796	0.96	849	1.06
	2,700	480	0.54	570	0.67	646	0.78	712	0.89	773	1.00	828	1.11	880	1.21
	3,000	533	0.69	616	0.82	687	0.94	750	1.05	808	1.16	862	1.28	912	1.39
40RM 40RMS 008	2,250	359	0.32	472	0.44	560	0.55	634	0.65	700	0.75	759	0.86	814	0.96
	2,600	415	0.45	516	0.57	599	0.68	669	0.79	732	0.90	790	1.01	843	1.11
	3,000	478	0.62	569	0.75	645	0.86	712	0.98	773	1.09	828	1.20	879	1.32
	3,400	542	0.82	624	0.95	695	1.08	758	1.20	815	1.31	869	1.43	918	1.55
	3,750	598	1.03	673	1.17	740	1.29	800	1.42	855	1.60	906	1.66	954	1.78
40RMS 010	2,550	396	0.42	502	0.54	586	0.65	658	0.76	722	0.87	780	0.97	833	1.08
	2,975	462	0.60	556	0.72	634	0.84	701	0.95	762	1.06	818	1.18	870	1.29
	3,400	527	0.80	612	0.93	684	1.06	748	1.18	806	1.30	860	1.41	910	1.53
	3,825	593	1.05	670	1.18	737	1.31	797	1.44	852	1.56	904	1.68	952	1.80
	4,250	659	1.33	729	1.47	791	1.60	848	1.73	901	1.86	950	1.98	997	2.11
40RM 40RMS 012	3,000	444	0.58	541	0.71	621	0.83	691	0.94	753	1.05	809	1.17	862	1.28
	3,500	518	0.82	604	0.95	677	1.08	742	1.20	801	1.32	855	1.44	906	1.56
	4,000	592	1.11	669	1.25	736	1.38	797	1.51	853	1.63	904	1.75	953	1.88
	4,500	666	1.44	735	1.59	797	1.72	854	1.86	907	1.99	956	2.12	1003	2.24
	5,000	740	1.83	803	1.98	861	2.12	914	2.26	964	2.39	1010	2.53	1055	2.66
40RM 40RMS 014	3,750	363	0.37	475	0.58	566	0.80	645	1.02	715	1.24	779	1.47	839	1.69
	4,300	416	0.53	517	0.78	601	1.02	676	1.26	743	1.50	805	1.74	862	1.99
	5,000	484	0.81	573	1.08	650	1.35	719	1.62	782	1.89	841	2.16	896	2.44
	5,700	552	1.17	631	1.47	702	1.76	766	2.06	826	2.36	881	2.66	934	2.96
	6,250	605	1.51	678	1.83	744	2.15	805	2.47	862	2.79	915	3.11	966	3.43
40RM 40RMS 016	4,500	391	0.51	495	0.75	581	1.00	657	1.25	725	1.50	787	1.76	845	2.02
	5,300	460	0.80	551	1.08	629	1.35	700	1.63	764	1.91	823	2.20	878	2.48
	6,000	521	1.13	602	1.43	675	1.73	741	2.04	801	2.34	858	2.65	911	2.96
	6,800	590	1.60	663	1.93	730	2.26	791	2.59	847	2.92	901	3.26	951	3.60
	7,500	651	2.10	718	2.45	779	2.81	837	3.16	890	3.52	941	3.88	990	4.24
40RM 40RMS 024	6,000	503	1.07	587	1.37	661	1.67	727	1.97	789	2.28	846	2.59	900	2.90
	7,000	586	1.64	660	1.98	726	2.31	787	2.65	844	2.99	898	3.33	948	3.67
	8,000	670	2.37	735	2.74	795	3.12	851	3.49	904	3.86	954	4.23	1001	4.61
	9,000	754	3.28	812	3.69	867	4.09	918	4.50	967	4.90	1014	5.31	1059	5.72
	10,000	838	4.39	891	4.83	941	5.27	988	5.70	1034	6.14	1077	6.85	1120	7.02
40RM 40RMS 028	7,500	412	1.15	492	1.53	568	2.00	640	2.56	710	3.22	776	3.98	840	4.83
	8,750	481	1.76	550	2.17	616	2.66	680	3.22	742	3.86	802	4.58	860	5.38
	10,000	549	2.55	610	2.99	669	3.50	726	4.07	782	4.70	836	5.40	889	6.17
	11,250	618	3.52	672	4.00	725	4.53	777	5.12	827	5.76	876	6.45	925	7.21
	12,500	687	4.71	735	5.22	783	5.78	830	6.38	876	7.04	922	7.74	966	8.49
40RM 40RMS 034	9,000	471	1.78	539	2.17	604	2.63	667	3.17	728	3.78	788	4.46	845	5.22
	10,500	550	2.72	608	3.15	665	3.64	720	4.18	774	4.79	827	5.45	878	6.18
	12,000	628	3.93	679	4.40	730	4.92	779	5.48	827	6.09	874	6.76	921	7.47
	13,500	707	5.44	752	5.94	797	6.49	841	7.08	885	7.71	928	8.38	970	9.10
	15,000	785	7.27	826	7.81	867	8.39	907	9.01	947	9.66	986	10.35	1024	11.07

40RM/RMS

See Legend and Notes on page 32.

FAN PERFORMANCE DATA — 1.4-2.4 in. wg ESP — 50 Hz, ENGLISH

UNIT	AIRFLOW (Cfm)	EXTERNAL STATIC PRESSURE (in. wg)											
		1.4		1.6		1.8		2.0		2.2		2.4	
		Rpm	Bhp	Rpm	Bhp	Rpm	Bhp	Rpm	Bhp	Rpm	Bhp	Rpm	Bhp
40RM 007	1,800	847	0.89	896	0.98	942	1.07	986	1.16	1027	1.25	—	—
	2,100	872	1.02	920	1.11	965	1.21	1008	1.30	1050	1.40	—	—
	2,400	899	1.16	946	1.26	990	1.36	1033	1.46	1073	1.55	—	—
	2,700	928	1.32	974	1.42	1018	1.52	1059	1.63	1099	1.73	—	—
	3,000	959	1.49	1004	1.60	1046	1.71	1087	1.81	1126	1.92	—	—
40RM 40RMS 008	2,250	865	1.06	913	1.16	958	1.27	1001	1.37	1042	1.47	—	—
	2,600	893	1.22	940	1.33	984	1.43	1027	1.54	1067	1.65	—	—
	3,000	928	1.43	973	1.54	1017	1.65	1058	1.76	1098	1.87	—	—
	3,400	965	1.66	1010	1.78	1052	1.89	1092	2.00	1131	2.12	—	—
	3,750	1000	1.90	1043	2.02	1084	2.13	1124	2.25	1162	2.37	—	—
40RMS 010	2,550	884	1.18	931	1.29	975	1.40	1018	1.50	1059	1.61	—	—
	2,975	919	1.40	965	1.51	1009	1.62	1050	1.73	1090	1.84	—	—
	3,400	957	1.64	1002	1.76	1044	1.87	1085	1.98	1124	2.10	—	—
	3,825	998	1.92	1041	2.04	1082	2.16	1122	2.27	1160	2.39	—	—
	4,250	1041	2.23	1083	2.35	1123	2.48	1161	2.60	1199	2.72	—	—
40RM 40RMS 012	3,000	911	1.39	958	1.50	1002	1.61	1044	1.72	1084	1.83	1123	1.94
	3,500	953	1.67	998	1.79	1041	1.90	1082	2.02	1122	2.13	1159	2.25
	4,000	999	2.00	1042	2.12	1084	2.24	1124	2.36	1162	2.48	1199	2.60
	4,500	1047	2.37	1089	2.50	1129	2.62	1168	2.74	—	—	—	—
	5,000	1097	2.79	1138	2.92	1177	3.05	—	—	—	—	—	—
40RM 40RMS 014	3,750	894	1.91	947	2.14	996	2.37	1044	2.60	1089	2.83	—	—
	4,300	916	2.23	967	2.48	1016	2.73	1062	2.98	1107	3.24	—	—
	5,000	948	2.71	997	2.98	1044	3.26	1089	3.53	1133	3.81	—	—
	5,700	984	3.25	1031	3.55	1076	3.86	1120	4.16	1162	4.46	—	—
	6,250	1014	3.75	1060	4.07	1104	4.39	1147	4.71	1188	5.03	—	—
40RM 40RMS 016	4,500	899	2.29	951	2.56	999	2.84	1046	3.12	1091	3.41	1133	3.70
	5,300	930	2.78	980	3.08	1027	3.38	1072	3.68	1116	3.99	1157	4.30
	6,000	961	3.28	1009	3.60	1055	3.92	1098	4.24	1141	4.57	1181	4.91
	6,800	999	3.94	1045	4.28	1089	4.63	1132	4.98	1173	5.33	—	—
	7,500	1036	4.60	1080	4.97	1123	5.34	1164	5.71	—	—	—	—
40RM 40RMS 024	6,000	950	3.21	999	3.53	1045	3.85	1089	4.17	1131	4.50	1172	4.83
	7,000	996	4.02	1042	4.37	1086	4.72	1129	5.07	1169	5.43	—	—
	8,000	1047	4.99	1091	5.37	1133	5.75	1173	6.13	—	—	—	—
	9,000	1102	6.13	1143	6.54	1183	6.96	—	—	—	—	—	—
	10,000	1160	7.46	1200	7.91	—	—	—	—	—	—	—	—
40RM 40RMS 028	7,500	903	5.79	963	6.83	1021	7.98	1078	9.21	—	—	—	—
	8,750	917	6.26	972	7.22	1025	8.26	1078	9.38	—	—	—	—
	10,000	941	7.01	991	7.91	1040	8.89	1089	9.93	—	—	—	—
	11,250	972	8.02	1019	8.89	1064	9.83	—	—	—	—	—	—
	12,500	1010	9.29	1053	10.15	1095	11.05	—	—	—	—	—	—
40RM 40RMS 034	9,000	901	6.07	955	6.98	1008	7.98	1060	9.05	—	—	—	—
	10,500	928	6.98	978	7.84	1026	8.76	1073	9.74	—	—	—	—
	12,000	966	8.24	1011	9.07	1055	9.95	1098	10.88	—	—	—	—
	13,500	1011	9.86	1052	10.67	1092	11.52	—	—	—	—	—	—
	15,000	1062	11.84	—	—	—	—	—	—	—	—	—	—

40RM/RMS

See Legend and Notes on page 32.

Performance data (cont)

LEGEND

Bhp - Brake Horsepower Input to Fan
ESP - External Static Pressure

Bold indicates field supplied drive is required.

Plain type indicates standard motor and standard drive.

Underline indicates a different motor and drive combination other than the standard motor and standard drive combination is required. Refer to fan motor and drive tables, pages 52-59, to complete selection.

NOTES:

1. Maximum allowable fan speed is 1100 rpm for unit sizes 028 and 034; 1200 rpm for all other sizes.
2. Fan performance is based on deductions for wet coil, clean 1-in. filters, and unit casing. See table at right for factory-supplied filter pressure drop.
3. For 60 Hz units, the medium-static drive and standard motor combination is not available for 028 size. For 50 Hz units, the medium-static drive and standard motor combination is not available for 016-028 sizes. Use alternate motor if medium-static drive is required for these sizes.

FACTOR Y-SUPPLIED FILTER PRESSURE DROP - ENGLISH

UNIT	AIRFLOW (Cfm)	PRESSURE DROP (in. wg)
40RM 007	1,800	0.05
	2,400	0.08
	3,000	0.11
40RM 40RMS 008	2,250	0.07
	3,000	0.11
	3,750	0.15
40RMS 010	2,550	0.09
	3,400	0.13
	4,250	0.18
40RM 40RMS 012	3,000	0.11
	4,000	0.17
	5,000	0.23
40RM 40RMS 014	3,750	0.06
	5,000	0.10
	6,250	0.13
40RM 40RMS 016	4,500	0.08
	6,000	0.12
	7,500	0.17
40RM 40RMS 024	6,000	0.12
	8,000	0.19
	10,000	0.26
40RM 40RMS 028	7,500	0.15
	10,000	0.22
	12,500	0.30
40RM 40RMS 034	9,000	0.19
	12,000	0.29
	15,000	0.40

40RM/RMS

FAN PERFORMANCE DATA — 0-300 Pa ESP — 60 Hz, SI

UNIT	AIRFLOW (L/s)	EXTERNAL STATIC PRESSURE (Pa)													
		0		50		100		150		200		250		300	
		r/s	kW	r/s	kW	r/s	kW	r/s	kW	r/s	kW	r/s	kW	r/s	kW
40RM 007	850	5.34	0.17	7.38	0.25	8.91	0.32	10.20	0.39	11.30	0.46	12.30	0.53	13.30	0.60
	1000	6.28	0.24	8.10	0.32	9.53	0.40	10.80	0.48	11.80	0.55	12.80	0.63	13.70	0.70
	1150	7.22	0.33	8.86	0.41	10.20	0.50	11.40	0.58	12.40	0.66	13.40	0.73	14.20	0.81
	1300	8.17	0.43	9.64	0.52	10.90	0.61	12.00	0.69	13.00	0.77	13.90	0.85	14.80	0.93
	1450	9.11	0.55	10.50	0.64	11.60	0.73	12.70	0.82	13.60	0.91	14.50	0.99	15.40	1.07
40RM 40RMS 008	1000	5.63	0.22	7.61	0.30	9.11	0.38	10.40	0.45	11.50	0.53	12.50	0.61	13.40	0.68
	1200	6.76	0.32	8.49	0.41	9.88	0.50	11.10	0.57	12.10	0.66	13.10	0.74	14.00	0.82
	1400	7.89	0.46	9.42	0.55	10.70	0.64	11.80	0.72	12.80	0.81	13.80	0.89	14.60	0.97
	1600	9.01	0.62	10.40	0.71	11.60	0.80	12.60	0.89	13.60	0.98	14.50	1.07	15.30	1.16
	1800	10.10	0.80	11.40	0.90	12.50	0.10	13.50	1.09	14.40	1.18	15.20	1.27	16.00	1.36
40RMS 010	1200	6.58	0.31	8.35	0.40	9.76	0.49	11.00	0.57	12.00	0.65	13.00	0.73	13.90	0.81
	1400	7.67	0.44	9.25	0.54	10.60	0.63	11.70	0.71	12.70	0.80	13.60	0.88	14.50	0.96
	1600	8.77	0.60	10.20	0.70	11.40	0.79	12.50	0.88	13.40	0.97	14.30	1.05	15.20	1.14
	1800	9.86	0.78	11.10	0.88	12.30	0.98	13.30	1.07	14.20	1.16	15.10	1.25	15.90	1.34
	2000	11.00	0.99	12.10	1.09	13.20	1.19	14.10	1.29	15.00	3.38	15.80	1.48	16.60	1.57
40RM 40RMS 012	1450	7.58	0.46	9.18	0.56	10.50	0.65	11.60	0.73	12.70	0.82	13.60	0.90	14.50	0.99
	1670	8.73	0.63	10.20	0.73	11.40	0.83	12.50	0.92	13.40	1.01	14.30	1.10	15.20	1.18
	1900	9.93	0.84	11.20	0.95	12.30	1.05	13.30	1.14	14.30	1.24	15.10	1.33	15.90	1.42
	2120	11.10	1.08	12.20	1.18	13.30	1.29	14.20	1.39	15.10	1.48	15.90	1.58	16.70	1.68
	2350	12.30	1.36	13.30	1.17	14.30	1.57	15.20	1.68	16.00	1.78	16.80	1.88	17.60	1.98
40RM 40RMS 014	1750	5.99	0.27	7.88	0.43	9.41	0.59	10.70	0.75	11.90	0.92	13.00	1.08	14.00	1.25
	2050	7.01	0.41	8.68	0.60	10.10	0.78	11.30	0.96	12.40	1.14	13.50	1.33	14.40	1.51
	2350	8.04	0.60	9.53	0.81	10.80	1.01	12.00	1.21	13.00	1.41	14.00	1.61	14.90	1.82
	2650	9.07	0.84	10.40	1.06	11.60	1.28	12.70	1.50	13.70	1.72	14.60	1.94	15.50	2.16
	2950	10.10	1.13	11.30	1.37	12.40	1.61	13.40	1.85	14.40	2.08	15.30	2.32	16.10	2.56
40RM 40RMS 016	2100	6.43	0.37	8.19	0.55	9.65	0.73	10.90	0.92	12.10	1.11	13.10	1.30	14.10	1.50
	2450	7.51	0.57	9.06	0.77	10.40	0.97	11.60	1.18	12.70	1.39	13.70	1.60	14.60	1.81
	2800	8.58	0.82	9.96	1.05	11.20	1.27	12.30	1.49	13.30	1.72	14.30	1.95	15.10	2.18
	3150	9.65	1.14	10.90	1.38	12.00	1.63	13.10	1.87	14.00	2.12	14.90	2.36	15.80	2.61
	3500	10.70	1.52	11.90	1.78	12.90	2.05	13.90	2.31	14.80	2.58	15.60	2.84	16.40	3.11
40RM 40RMS 024	2900	8.58	0.86	9.96	1.09	11.20	1.32	12.30	1.55	13.30	1.78	14.20	2.01	15.10	2.25
	3350	9.91	1.28	11.10	1.53	12.20	1.79	13.20	2.04	14.20	2.30	15.10	2.55	15.90	2.81
	3800	11.30	1.81	12.30	2.09	13.30	2.37	14.30	2.64	15.10	2.93	16.00	3.21	16.80	3.49
	4250	12.60	2.46	13.60	2.76	14.50	3.07	15.30	3.37	16.10	3.67	16.90	3.98	17.70	4.28
	4700	13.90	3.24	14.80	3.57	15.60	3.90	16.40	4.22	17.20	4.55	17.90	4.88	18.60	5.21
40RM 40RMS 028	3500	6.79	0.84	8.14	1.12	9.42	1.47	10.70	1.89	11.80	2.39	12.90	2.96	14.00	3.61
	4100	7.95	1.29	9.12	1.60	10.20	1.96	11.30	2.38	12.40	2.86	13.40	3.40	14.30	4.00
	4700	9.12	1.88	10.10	2.21	11.10	2.59	12.10	3.02	13.00	3.49	13.90	4.02	14.80	4.60
	5300	10.30	2.62	11.20	3.00	12.10	3.37	12.90	3.81	13.80	4.29	14.60	4.82	15.40	5.38
	5900	11.40	3.52	12.30	3.90	13.10	4.32	13.90	4.77	14.60	5.26	15.40	5.79	16.10	6.35
40RM 40RMS 034	4250	7.86	1.33	8.99	1.63	10.10	1.97	11.10	2.37	12.20	2.83	13.20	3.34	14.10	3.92
	4950	9.15	2.03	10.10	2.35	11.10	2.72	12.00	3.12	12.90	3.58	13.80	4.08	14.70	4.62
	5650	10.40	2.92	11.30	3.27	12.20	3.66	13.00	4.08	13.80	4.54	14.60	5.04	15.40	5.57
	6350	11.70	4.02	12.50	4.40	13.30	4.81	14.00	5.25	14.70	5.72	15.50	6.23	16.20	6.77
	7050	13.00	5.37	13.70	5.77	14.40	6.21	15.10	6.66	15.70	7.15	16.40	7.67	17.10	8.21

40RM/RMS

See Legend and Notes on page 37.

Performance data (cont)

FAN PERFORMANCE DATA — 350-600 Pa ESP — 60 Hz, SI

UNIT	AIRFLOW (L/s)	EXTERNAL STATIC PRESSURE (Pa)											
		350		400		450		500		550		600	
		r/s	kW	r/s	kW	r/s	kW	r/s	kW	r/s	kW	r/s	kW
40RM 007	850	14.10	0.67	15.00	0.74	15.70	0.81	16.50	0.87	17.20	0.94	—	—
	1000	14.60	0.77	15.40	0.84	16.10	0.91	16.90	0.98	17.60	1.06	—	—
	1150	15.10	0.88	15.90	0.96	16.60	1.03	17.30	1.11	18.00	1.18	—	—
	1300	15.60	1.01	16.40	1.09	17.10	1.17	17.80	1.25	18.40	1.32	—	—
	1450	16.10	1.15	16.90	1.24	17.60	1.32	18.30	1.40	18.90	1.48	—	—
40RM 40RMS 008	1000	14.30	0.76	15.10	0.83	15.80	0.91	16.60	0.99	17.30	1.06	—	—
	1200	14.80	0.90	15.60	0.98	16.40	1.05	17.10	1.13	17.80	1.21	—	—
	1400	15.40	1.06	16.20	1.14	16.90	1.22	17.60	1.30	18.30	1.39	—	—
	1600	16.10	1.24	16.80	1.33	17.50	1.41	18.20	1.50	18.90	1.58	—	—
	1800	16.80	1.45	17.50	1.54	18.20	1.63	18.90	1.72	19.50	1.80	—	—
40RMS 010	1200	14.70	0.89	15.50	0.97	16.30	1.05	17.00	1.12	17.70	1.20	—	—
	1400	15.30	1.05	16.10	1.13	16.80	1.21	17.50	1.29	18.20	1.37	—	—
	1600	16.00	1.23	16.70	1.31	17.40	1.40	18.10	1.48	18.80	1.57	—	—
	1800	16.60	1.43	17.40	1.52	18.10	1.61	18.70	1.70	19.40	1.79	—	—
	2000	17.30	1.66	18.00	1.76	18.70	1.85	19.40	1.94	—	—	—	—
40RM 40RMS 012	1450	15.30	1.07	16.10	1.15	16.80	1.24	17.50	1.32	18.20	1.40	18.80	1.48
	1670	16.00	1.27	16.70	1.36	17.40	1.44	18.10	1.53	18.80	1.62	19.40	1.70
	1900	16.70	1.51	17.40	1.60	18.10	1.69	18.80	1.78	19.40	1.87	—	—
	2120	17.50	1.77	18.20	1.86	18.80	1.96	19.50	2.05	—	—	—	—
	2350	18.30	2.07	19.00	2.17	19.60	2.27	—	—	—	—	—	—
40RM 40RMS 014	1750	14.90	1.42	15.80	1.58	16.60	1.75	17.40	1.93	18.20	2.10	—	—
	2050	15.30	1.70	16.20	1.88	17.00	2.07	17.80	2.26	18.50	2.45	—	—
	2350	15.80	2.02	16.60	2.22	17.40	2.43	18.20	2.64	18.90	2.84	—	—
	2650	16.30	2.39	17.10	2.61	17.90	2.83	18.60	3.06	19.30	3.28	—	—
	2950	16.90	2.80	17.70	3.04	18.40	3.28	19.10	3.53	19.80	3.77	—	—
40RM 40RMS 016	2100	15.00	1.70	15.80	1.90	16.70	2.11	17.40	2.32	18.20	2.53	18.90	2.74
	2450	15.50	2.03	16.30	2.25	17.10	2.47	17.80	2.70	18.60	2.93	19.30	3.16
	2800	16.00	2.42	16.80	2.66	17.60	2.90	18.30	3.14	19.00	3.38	19.70	3.63
	3150	16.60	2.87	17.40	3.12	18.10	3.38	18.80	3.64	19.50	3.90	—	—
	3500	17.20	3.38	18.00	3.65	18.70	3.93	19.40	4.20	—	—	—	—
40RM 40RMS 024	2900	16.00	2.49	16.80	2.73	17.50	2.97	18.30	3.22	19.00	3.47	19.70	3.72
	3350	16.70	3.08	17.50	3.34	18.20	3.61	18.90	3.87	19.60	4.14	—	—
	3800	17.50	3.77	18.20	4.06	18.90	4.35	19.60	4.64	—	—	—	—
	4250	18.40	4.59	19.10	4.90	19.80	5.21	—	—	—	—	—	—
	4700	19.30	5.54	20.00	5.87	—	—	—	—	—	—	—	—
40RM 40RMS 028	3500	15.10	4.33	16.10	5.12	17.10	5.98	18.00	6.92	—	—	—	—
	4100	15.30	4.67	16.20	5.39	17.10	6.18	18.00	7.02	—	—	—	—
	4700	15.70	5.23	16.50	5.91	17.40	6.64	18.20	7.43	—	—	—	—
	5300	16.20	5.99	17.00	6.65	17.80	7.35	—	—	—	—	—	—
	5900	16.90	6.95	17.60	7.59	18.30	8.27	—	—	—	—	—	—
40RM 40RMS 034	4250	15.00	4.55	16.00	5.24	16.80	5.99	17.70	6.79	—	—	—	—
	4950	15.50	5.22	16.30	5.86	17.10	6.56	17.90	7.30	—	—	—	—
	5650	16.10	6.16	16.90	6.77	17.60	7.43	18.30	8.13	—	—	—	—
	6350	16.90	7.34	17.50	7.94	18.20	8.58	—	—	—	—	—	—
	7050	17.70	8.79	18.30	9.39	—	—	—	—	—	—	—	—

See Legend and Notes on page 37.

Performance data (cont)

FAN PERFORMANCE DATA — 350-600 Pa ESP — 50 Hz, SI

UNIT	AIRFLOW (L/s)	EXTERNAL STATIC PRESSURE (Pa)											
		350		400		450		500		550		600	
		r/s	kW	r/s	kW	r/s	kW	r/s	kW	r/s	kW	r/s	kW
40RM 007	850	14.10	0.67	15.00	0.74	15.70	0.81	16.50	0.87	17.20	0.94	—	—
	1000	14.60	0.77	15.40	0.84	16.10	0.91	16.90	0.98	17.60	1.06	—	—
	1150	15.10	0.88	15.90	0.96	16.60	1.03	17.30	1.11	18.00	1.18	—	—
	1300	15.60	1.01	16.40	1.09	17.10	1.17	17.80	1.25	18.40	1.32	—	—
	1450	16.10	1.15	16.90	1.24	17.60	1.32	18.30	1.40	18.90	1.48	—	—
40RM 40RMS 008	1000	14.30	0.76	15.10	0.83	15.80	0.91	16.60	0.99	17.30	1.06	—	—
	1200	14.80	0.90	15.60	0.98	16.40	1.05	17.10	1.13	17.80	1.21	—	—
	1400	15.40	1.06	16.20	1.14	16.90	1.22	17.60	1.30	18.30	1.39	—	—
	1600	16.10	1.24	16.80	1.33	17.50	1.41	18.20	1.50	18.90	1.58	—	—
	1800	16.80	1.45	17.50	1.54	18.20	1.63	18.90	1.72	19.50	1.80	—	—
40RMS 010	1200	14.70	0.89	15.50	0.97	16.30	1.05	17.00	1.12	17.70	1.20	—	—
	1400	15.30	1.05	16.10	1.13	16.80	1.21	17.50	1.29	18.20	1.37	—	—
	1600	16.00	1.23	16.70	1.31	17.40	1.40	18.10	1.48	18.80	1.57	—	—
	1800	16.60	1.43	17.40	1.52	18.10	1.61	18.70	1.70	19.40	1.79	—	—
	2000	17.30	1.66	18.00	1.76	18.70	1.85	19.40	1.94	—	—	—	—
40RM 40RMS 012	1450	15.30	1.07	16.10	1.15	16.80	1.24	17.50	1.32	18.20	1.40	18.80	1.48
	1670	16.00	1.27	16.70	1.36	17.40	1.44	18.10	1.53	18.80	1.62	19.40	1.70
	1900	16.70	1.51	17.40	1.60	18.10	1.69	18.80	1.78	19.40	1.87	—	—
	2120	17.50	1.77	18.20	1.86	18.80	1.96	19.50	2.05	—	—	—	—
	2350	18.30	2.07	19.00	2.17	19.60	2.27	—	—	—	—	—	—
40RM 40RMS 014	1750	14.90	1.42	15.80	1.58	16.60	1.75	17.40	1.93	18.20	2.10	—	—
	2050	15.30	1.70	16.20	1.88	17.00	2.07	17.80	2.26	18.50	2.45	—	—
	2350	15.80	2.02	16.60	2.22	17.40	2.43	18.20	2.64	18.90	2.84	—	—
	2650	16.30	2.39	17.10	2.61	17.90	2.83	18.60	3.06	19.30	3.28	—	—
	2950	16.90	2.80	17.70	3.04	18.40	3.28	19.10	3.53	19.80	3.77	—	—
40RM 40RMS 016	2100	15.00	1.70	15.80	1.90	16.70	2.11	17.40	2.32	18.20	2.53	18.90	2.74
	2450	15.50	2.03	16.30	2.25	17.10	2.47	17.80	2.70	18.60	2.93	19.30	3.16
	2800	16.00	2.42	16.80	2.66	17.60	2.90	18.30	3.14	19.00	3.38	19.70	3.63
	3150	16.60	2.87	17.40	3.12	18.10	3.38	18.80	3.64	19.50	3.90	—	—
	3500	17.20	3.38	18.00	3.65	18.70	3.93	19.40	4.20	—	—	—	—
40RM 40RMS 024	2900	16.00	2.49	16.80	2.73	17.50	2.97	18.30	3.22	19.00	3.47	19.70	3.72
	3350	16.70	3.08	17.50	3.34	18.20	3.61	18.90	3.87	19.60	4.14	—	—
	3800	17.50	3.77	18.20	4.06	18.90	4.35	19.60	4.64	—	—	—	—
	4250	18.40	4.59	19.10	4.90	19.80	5.21	—	—	—	—	—	—
	4700	19.30	5.54	20.00	5.87	—	—	—	—	—	—	—	—
40RM 40RMS 028	3500	15.10	4.33	16.10	5.12	17.10	5.98	18.00	6.92	—	—	—	—
	4100	15.30	4.67	16.20	5.39	17.10	6.18	18.00	7.02	—	—	—	—
	4700	15.70	5.23	16.50	5.91	17.40	6.64	18.20	7.43	—	—	—	—
	5300	16.20	5.99	17.00	6.65	17.80	7.35	—	—	—	—	—	—
	5900	16.90	6.95	17.60	7.59	18.30	8.27	—	—	—	—	—	—
40RM 40RMS 034	4250	15.00	4.55	16.00	5.24	16.80	5.99	17.70	6.79	—	—	—	—
	4950	15.50	5.22	16.30	5.86	17.10	6.56	17.90	7.30	—	—	—	—
	5650	16.10	6.16	16.90	6.77	17.60	7.43	18.30	8.13	—	—	—	—
	6350	16.90	7.34	17.50	7.94	18.20	8.58	—	—	—	—	—	—
	7050	17.70	8.79	18.30	9.39	—	—	—	—	—	—	—	—

See Legend and Notes on page 37.

LEGEND

ESP - External Static Pressure

Bold indicates field-supplied drive is required.

Plain type indicates standard motor and standard drive.

Underline indicates a different motor and drive combination other than the standard motor and standard drive combination is required. Refer to fan motor and drive tables, pages 52-69, to complete the selection.

NOTES:

1. Maximum allowable fan speed is 18.3 r/s for unit sizes 028 and 034; 20 r/s for all other sizes.
2. Fan performance is based on deductions for wet coil, clean 25.4 mm filters, and unit casing. See table below for factory-supplied filter pressure drop.
3. For 60 Hz units, the medium-static drive and standard motor combination is not available for 028 size. For 50 Hz units, the medium-static drive and standard motor combination is not available for 016-028 sizes. Use alternate motor if medium-static drive is required for these sizes.

FACTOR Y-SUPPLIED FILTER PRESSURE DROP - SI

UNIT	AIRFLOW (L/s)	PRESSURE DROP (Pa)
40RM 007	850	13
	1150	20
	1450	28
40RM 40RMS 008	1000	17
	1400	27
	1800	38
40RMS 010	1200	21
	1600	32
	2000	45
40RM 40RMS 012	1450	28
	1900	42
	2350	56
40RM 40RMS 014	1750	15
	2350	24
	2950	33
40RM 40RMS 016	2100	20
	2800	30
	3500	42
40RM 40RMS 024	2900	32
	3800	47
	4700	64
40RM 40RMS 028	3500	36
	4700	55
	5900	76
40RM 40RMS 034	4250	47
	5650	71
	7050	98

40RM/RMS

Performance data (cont)

**ACCESSORY PLENUM AIR THROW DATA — ENGLISH
(Ft)**

UNIT	AIRFLOW (Cfm)	VANE DEFLECTION		
		Straight	21½°	45°
40RM 007	2,400	39	33	24
40RM 40RMS 008	3,000	45	38	28
40RMS 010	3,400	49	41	30
40RM 40RMS 012	4,000	55	46	33
40RM 40RMS 014	5,000	45	38	28
40RM 40RMS 016	6,000	50	43	31
40RM 40RMS 024	8,000	60	51	37
40RM 40RMS 028	10,000	76	65	47
40RM 40RMS 034	12,000	85	72	52

**ACCESSORY PLENUM AIR THROW DATA — SI
(m)**

UNIT	AIRFLOW (L/s)	VANE DEFLECTION		
		Straight	21½°	45°
40RM 007	1150	11.71	9.91	7.20
40RM 40RMS 008	1400	13.87	11.71	8.63
40RMS 010	1600	14.98	12.53	9.17
40RM 40RMS 012	1900	16.65	13.93	9.99
40RM 40RMS 014	2350	13.77	11.63	8.57
40RM 40RMS 016	2800	15.41	13.25	9.55
40RM 40RMS 024	3800	18.17	15.44	11.20
40RM 40RMS 028	4700	23.26	19.89	14.38
40RM 40RMS 034	5650	25.97	22.00	15.89

NOTE: Throw distances shown are for 75 fpm terminal velocity. Use the following multipliers to determine throw values for other terminal velocities.

TERMINAL VELOCITY (Fpm)	THROW FACTOR
50	X 1.50
100	X 0.75
150	X 0.50

NOTE: Throw distances shown are for 0.381 m/sec terminal velocity. Use the following multipliers to determine throw values for other terminal velocities.

TERMINAL VELOCITY (m/sec)	THROW FACTOR
0.254	X 1.50
0.508	X 0.75
0.762	X 0.50

40RM/RMS

ACCESSORY PRESSURE DROP — ENGLISH
(in. wg)

UNIT	AIRFLOW (Cfm)	DISCHARGE PLENUM	RETURN AIR GRILLE	HEATING COILS			ECONOMIZER
				Hot Water	Steam	Electric	
40RM 007	1,800	0.06	0.01	0.10	0.10	0.04	0.05
	2,400	0.10	0.01	0.16	0.16	0.06	0.07
	3,000	0.14	0.02	0.23	0.23	0.10	0.09
40RM 40RMS 008	2,250	0.09	0.01	0.15	0.15	0.06	0.06
	3,000	0.14	0.02	0.23	0.23	0.10	0.09
	3,750	0.21	0.03	0.35	0.35	0.15	0.15
40RMS 010	2,550	0.11	0.02	0.18	0.18	0.07	0.07
	3,400	0.17	0.03	0.28	0.28	0.12	0.13
	4,250	0.24	0.04	0.41	0.41	0.19	0.19
40RM 40RMS 012	3,000	0.14	0.02	0.23	0.23	0.10	0.09
	4,000	0.22	0.04	0.37	0.37	0.17	0.17
	5,000	0.32	0.06	0.53	0.53	0.26	0.28
40RM 40RMS 014	3,750	0.07	0.01	0.11	0.11	0.04	0.05
	5,000	0.12	0.02	0.17	0.17	0.07	0.07
	6,250	0.17	0.02	0.25	0.25	0.11	0.11
40RM 40RMS 016	4,500	0.10	0.01	0.15	0.15	0.06	0.06
	6,000	0.16	0.02	0.23	0.23	0.10	0.09
	7,500	0.23	0.03	0.33	0.33	0.15	0.15
40RM 40RMS 024	6,000	0.16	0.02	0.23	0.23	0.10	0.09
	8,000	0.26	0.04	0.37	0.37	0.17	0.17
	10,000	0.37	0.06	0.53	0.53	0.26	0.28
40RM 40RMS 028	7,500	0.15	0.02	0.28	0.28	0.09	0.06
	10,000	0.24	0.03	0.44	0.44	0.16	0.09
	12,500	0.34	0.05	0.63	0.63	0.24	0.14
40RM 40RMS 034	9,000	0.20	0.03	0.37	0.37	0.13	0.08
	12,000	0.32	0.05	0.59	0.59	0.22	0.14
	15,000	0.46	0.07	0.85	0.85	0.34	0.21

40RM/RMS

ACCESSORY PRESSURE DROP — SI
(Pa)

UNIT	AIRFLOW (L/s)	DISCHARGE PLENUM	RETURN AIR GRILLE	HEATING COILS			ECONOMIZER
				Hot Water	Steam	Electric	
40RM 007	850	15	2	25	25	9	12
	1150	25	3	41	41	16	18
	1450	36	5	60	60	26	23
40RM 40RMS 008	1000	20	2	33	33	12	13
	1400	34	5	57	57	24	22
	1800	51	8	85	85	39	39
40RMS 010	1200	26	5	44	44	18	17
	1600	42	7	70	70	31	32
	2000	61	10	101	101	48	47
40RM 40RMS 012	1450	36	5	60	60	26	23
	1900	56	10	93	93	43	43
	2350	79	15	132	132	65	69
40RM 40RMS 014	1750	18	2	26	26	10	12
	2350	29	5	43	43	17	17
	2950	43	5	62	62	26	27
40RM 40RMS 016	2100	24	2	36	36	14	15
	2800	39	5	57	57	24	22
	3500	56	7	82	82	37	37
40RM 40RMS 024	2900	41	5	60	60	26	23
	3800	64	10	93	93	43	43
	4700	91	15	132	132	65	69
40RM 40RMS 028	3500	37	5	67	67	22	15
	4700	59	7	109	109	39	22
	5900	86	12	157	157	60	35
40RM 40RMS 034	4250	50	7	92	92	32	20
	5650	80	12	147	147	56	35
	7050	114	17	210	210	85	52

Electrical data

STANDARD MOTORS

UNIT	V*-PH-Hz	VOLTAGE LIMITS	FAN MOTOR		POWER SUPPLY	
			Hp (kW)	FLA	Minimum Circuit Amps	MOCP
40RM 007	208/230-1-60	187-253	1.3 (0.97)	7.6	9.5	15
	208/230-3-60	187-253	2.4 (1.79)	5.2	6.5	15
	460-3-60	414-506	2.4 (1.79)	2.6	3.3	15
	575-3-60	518-632	1.0 (0.75)	1.4	8.0	15
	230-3-50	207-253	2.4 (1.79)	5.2	6.5	15
	400-3-50	360-440	2.4 (1.79)	2.6	3.3	15
40RM 40RMS 008	208/230-1-60	187-253	2.4 (1.79)	11.0	13.8	20
	208/230-3-60	187-253	2.4 (1.79)	5.2	6.5	15
	460-3-60	414-506	2.4 (1.79)	2.6	3.3	15
	575-3-60	518-632	2.0 (1.49)	2.3	2.9	15
	230-3-50	207-253	2.4 (1.79)	5.2	6.5	15
	400-3-50	360-440	2.4 (1.79)	2.6	3.3	15
40RMS 010	208/230-1-60	187-253	2.4 (1.79)	11.0	13.8	20
	208/230-3-60	187-253	2.4 (1.79)	5.2	6.5	15
	460-3-60	414-506	2.4 (1.79)	2.6	3.3	15
	575-3-60	518-632	2.0 (1.49)	2.3	2.9	15
	230-3-50	207-253	2.4 (1.79)	5.2	6.5	15
	400-3-50	360-440	2.4 (1.79)	2.6	3.3	15
40RM 40RMS 012	208/230-3-60	187-253	2.4 (1.79)	5.2	6.5	20
	460-3-60	414-506	2.4 (1.79)	2.6	3.3	15
	575-3-60	518-632	2.0 (1.49)	2.3	2.9	15
	230-3-50	207-253	2.9 (2.16)	7.5	9.4	15
	400-3-50	360-440	2.9 (2.16)	3.4	4.3	15
40RM 40RMS 014	208/230-3-60	187-253	2.9 (2.16)	7.5	9.4	15
	460-3-60	414-506	2.9 (2.16)	3.4	4.3	15
	575-3-60	518-632	3.0 (2.24)	3.8	4.8	15
	230-3-50	207-253	2.9 (2.16)	7.5	9.4	15
	400-3-50	360-440	2.9 (2.16)	3.4	4.3	15
40RM 40RMS 016	208/230-3-60	187-253	3.7 (2.76)	10.2	12.8	20
	460-3-60	414-506	3.7 (2.76)	4.8	6.0	15
	575-3-60	518-632	3.0 (2.24)	3.8	4.8	15
	230-3-50	207-253	2.9 (2.16)	7.5	9.4	15
	400-3-50	360-440	2.9 (2.16)	3.4	4.3	15
40RM 40RMS 024	208/230-3-60	187-253	5.0 (3.73)	15.3/12.8	19.1/16.0	30/25
	460-3-60	414-506	5.0 (3.73)	6.4	8.0	15
	575-3-60	518-632	5.0 (3.73)	5.1	6.4	15
	230-3-50	207-253	5.0 (3.73)	15.2	19.0	30
	400-3-50	360-440	5.0 (3.73)	7.6	9.5	15
40RM 40RMS 028	208/230-3-60	187-253	7.5 (5.59)	22.4/19.4	28.0/24.3	50/40
	460-3-60	414-506	7.5 (5.59)	9.7	12.1	20
	575-3-60	518-632	7.5 (5.59)	7.8	9.8	15
	230-3-50	207-253	7.5 (5.59)	22.8	28.5	50
	400-3-50	360-440	7.5 (5.59)	11.4	14.3	25
40RM 40RMS 034	208/230-3-60	187-253	10.0 (7.46)	29.3/26.8	36.6/33.5	60/60
	460-3-60	414-506	10.0 (7.46)	13.4	16.8	30
	575-3-60	518-632	10.0 (7.46)	10.3	12.9	20
	230-3-50	207-253	10.0 (7.46)	32.2	40.3	70
	400-3-50	360-440	10.0 (7.46)	16.1	20.1	30

See Legend and Notes on page 41.

ALTERNATE MOTORS

UNIT	V*-PH-Hz	VOLTAGE LIMITS	FAN MOTOR		POWER SUPPLY	
			Hp (kW)	FLA	Minimum Circuit Amps	MOCP
40RM 007	208/230-1-60	187-253	2.4 (1.79)	11.0	13.8	20
	208/230-3-60	187-253	2.9 (2.16)	7.5	9.4	15
	460-3-60	414-506	2.9 (2.16)	3.4	4.3	15
	575-3-60	518-632	2.0 (1.49)	2.3	2.9	15
	230-3-50	207-253	2.4 (1.79)	5.2	6.5	15
40RM 40RMS 008	400-3-50	360-440	2.4 (1.79)	2.6	3.3	15
	208/230-1-60	187-253	2.4 (1.79)	11.0	13.8	15
	208/230-3-60	187-253	2.9 (2.16)	7.5	9.4	15
	460-3-60	414-506	2.9 (2.16)	3.4	4.3	15
	575-3-60	518-632	3.0 (2.24)	3.8	4.8	15
40RMS 010	230-3-50	207-253	2.9 (2.16)	7.5	9.4	15
	400-3-50	360-440	2.9 (2.16)	3.4	4.3	15
	208/230-1-60	187-253	2.4 (1.79)	11.0	13.8	20
	208/230-3-60	187-253	2.9 (2.16)	7.5	9.4	15
	460-3-60	414-506	2.9 (2.16)	3.4	4.3	15
40RM 40RMS 012	575-3-60	518-632	3.0 (2.24)	3.8	4.8	15
	230-3-50	207-253	5.0 (3.73)	15.2	19.0	30
	400-3-50	360-440	5.0 (3.73)	7.6	9.5	15
	208/230-3-60	187-253	3.7 (2.76)	10.2	12.7	20
40RM 40RMS 014	460-3-60	414-506	3.7 (2.76)	4.8	6.0	15
	575-3-60	518-632	5.0 (3.73)	5.1	6.4	15
	230-3-50	207-253	5.0 (3.73)	15.2	19.0	30
	400-3-50	360-440	5.0 (3.73)	7.6	9.5	15
40RM 40RMS 016	208/230-3-60	187-253	5.0 (3.73)	15.3/12.8	19.1/16.0	30/25
	460-3-60	414-506	5.0 (3.73)	6.4	8.0	15
	575-3-60	518-632	5.0 (3.73)	5.1	6.4	15
	230-3-50	207-253	5.0 (3.73)	15.2	19.0	30
	400-3-50	360-440	5.0 (3.73)	7.6	9.5	15
40RM 40RMS 024	208/230-3-60	187-253	7.5 (5.59)	22.4/19.4	28.0/24.3	50/40
	460-3-60	414-506	7.5 (5.59)	9.7	12.1	20
	575-3-60	518-632	7.5 (5.59)	7.8	9.8	15
	230-3-50	207-253	7.5 (5.59)	22.8	28.5	50
	400-3-50	360-440	7.5 (5.59)	11.4	14.3	25
40RM 40RMS 028	208/230-3-60	187-253	10.0 (7.46)	29.3/26.8	36.6/33.5	60/60
	460-3-60	414-506	10.0 (7.46)	13.4	16.8	30
	575-3-60	518-632	10.0 (7.46)	10.3	12.9	20
	230-3-50	207-253	10.0 (7.46)	32.2	40.3	60
	400-3-50	360-440	10.0 (7.46)	16.1	20.1	30

40RM/RMS

LEGEND

FLA — Full Load Amps

MOCP — Maximum Overcurrent Protection

*Motors are designed for satisfactory operation within 10% of nominal voltages shown. Voltages should not exceed the limits shown in the Voltage Limits column.

NOTES:

1. Minimum circuit amps (MCA) and MOCP values are calculated in accordance with NEC (National Electrical Code) (U.S.A. standard), Article 440.
2. Motor FLA values are established in accordance with UL (Underwriters' Laboratories) Standard 1995 (U.S.A. standard).

3. Unbalanced 3-Phase Supply Voltage

Never operate a motor where a phase imbalance in supply voltage is greater than 2%. Use the following formula to determine the percentage of voltage imbalance.

% Voltage Imbalance

$$= 100 \times \frac{\text{max voltage deviation from average voltage}}{\text{average voltage}}$$

EXAMPLE: Supply voltage is 400-3-50.

AB = 393 v

BC = 403 v

AC = 396 v

$$\text{Average Voltage} = \frac{393 + 403 + 396}{3}$$

$$= \frac{1192}{3}$$

$$= 397$$

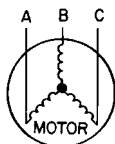

Determine maximum deviation from average voltage.

(AB) 397 - 393 = 4 v

(BC) 403 - 397 = 6 v

(AC) 397 - 396 = 1 v

Maximum deviation is 6 v.

Determine percent voltage imbalance.

$$\% \text{ Voltage Imbalance} = 100 \times \frac{6}{397}$$

$$= 1.5\%$$

This amount of phase imbalance is satisfactory because it is below the maximum allowable 2%.

IMPORTANT: If the supply voltage phase imbalance is more than 2%, contact your local electric utility company immediately.

Electrical data (cont)

ELECTRIC HEATER DATA

HEATER PART NO.	UNIT	V-PH-Hz	FAN MOTOR			ELECTRIC HEATER(S)					MCA*	MOCP*	
			Hp	kW	FLA	Nominal Capacity (kW)	Actual Capacity (kW)			FLA			
							Stage 1	Stage 2	Total				
CAELHEAT001A00	40RM007-012 40RMS008-012	208-3-60	1.3†	0.97	7.6	5	3.8	—	3.8	10.4	22.5	25	
			2.4†	1.79	11.0	5	3.8	—	3.8	10.4	26.8	35	
			2.4	1.79	5.2	5	3.8	—	3.8	10.4	19.5	20	
			2.9	2.16	7.5	5	3.8	—	3.8	10.4	22.4	25	
			3.7	2.76	10.2	5	3.8	—	3.8	10.4	25.8	30	
		240-3-60	1.3†	0.97	7.6	5	5.0	—	5.0	12.0	24.5	25	
			2.4†	1.79	11.0	5	5.0	—	5.0	12.0	28.8	35	
			2.4	1.79	5.2	5	5.0	—	5.0	12.0	21.5	25	
			2.9	2.16	7.5	5	5.0	—	5.0	12.0	24.4	25	
240-3-50	3.7	2.76	10.2	5	5.0	—	5.0	12.0	27.8	30			
	2.4	1.79	5.2	5	5.0	—	5.0	12.0	21.5	25			
	2.9	2.16	7.5	5	5.0	—	5.0	12.0	24.4	25			
5.0	3.73	15.2	5	5.0	—	5.0	12.0	34.0	40				
CAELHEAT002A00	40RM007-012 40RMS008-012	480-3-60	2.4	1.79	2.6	5	5.0	—	5.0	6.00	10.8	15	
			2.9	2.16	3.4	5	5.0	—	5.0	6.00	11.8	15	
			3.7	2.76	4.8	5	5.0	—	5.0	6.00	13.5	15	
400-3-50		2.4	1.79	2.6	5	3.5	—	3.5	5.00	9.5	15		
		2.9	2.16	3.4	5	3.5	—	3.5	5.00	10.5	15		
		5.0	3.73	7.6	5	3.5	—	3.5	5.00	15.8	20		
CAELHEAT003A00		40RM007-012 40RMS008-012	575-3-60	1.0	0.75	1.4	5	5.0	—	5.0	5.00	8.0	15
				2.0	1.49	2.3	5	5.0	—	5.0	5.00	9.2	15
				3.0	2.24	3.8	5	5.0	—	5.0	5.00	11.0	15
CAELHEAT004A00	208-3-60		1.3†	0.97	7.6	10	7.5	—	7.5	20.8	35.6	40	
			2.4†	1.79	11.0	10	7.5	—	7.5	20.8	39.8	40	
			2.4	1.79	5.2	10	7.5	—	7.5	20.8	32.6	35	
			2.9	2.16	7.5	10	7.5	—	7.5	20.8	35.4	40	
			3.7	2.76	10.2	10	7.5	—	7.5	20.8	38.8	40	
	240-3-60		1.3†	0.97	7.6	10	10.0	—	10.0	24.1	39.6	40	
		2.4†	1.79	11.0	10	10.0	—	10.0	24.1	43.8	50		
		2.4	1.79	5.2	10	10.0	—	10.0	24.1	36.6	40		
		2.9	2.16	7.5	10	10.0	—	10.0	24.1	39.4	40		
240-3-50	3.7	2.76	10.2	10	10.0	—	10.0	24.1	42.8	50			
	2.4	1.79	5.2	10	10.0	—	10.0	24.1	36.6	40			
	2.9	2.16	7.5	10	10.0	—	10.0	24.1	39.4	40			
5.0	3.73	15.2	10	10.0	—	10.0	24.1	49.1	50				
CAELHEAT005A00	40RM007-012 40RMS008-012	480-3-60	2.4	1.79	2.6	10	10.0	—	10.0	12.0	18.3	20	
			2.9	2.16	3.4	10	10.0	—	10.0	12.0	19.3	20	
			3.7	2.76	4.8	10	10.0	—	10.0	12.0	21.0	25	
400-3-50		2.4	1.79	2.6	10	6.9	—	6.9	10.0	15.8	20		
		2.9	2.16	3.4	10	6.9	—	6.9	10.0	16.8	20		
		5.0	3.73	7.6	10	6.9	—	6.9	10.0	22.0	25		
CAELHEAT006A00		40RM007-012 40RMS008-012	575-3-60	1.0	0.75	1.4	10	10.0	—	10.0	10.0	14.3	15
				2.0	1.49	2.3	10	10.0	—	10.0	10.0	15.4	20
				3.0	2.24	3.8	10	10.0	—	10.0	10.0	17.3	20
CAELHEAT007A00	208-3-60		1.3†	0.97	7.6	15	11.3	—	11.3	31.3	48.6	50	
			2.4†	1.79	11.0	15	11.3	—	11.3	31.3	52.9	60	
			2.4	1.79	5.2	15	11.3	—	11.3	31.3	45.6	50	
			2.9	2.16	7.5	15	11.3	—	11.3	31.3	48.5	50	
			3.7	2.76	10.2	15	11.3	—	11.3	31.3	51.9	60	
	240-3-60		1.3†	0.97	7.6	15	15.0	—	15.0	36.1	54.6	60	
		2.4†	1.79	11.0	15	15.0	—	15.0	36.1	58.9	60		
		2.4	1.79	5.2	15	15.0	—	15.0	36.1	51.6	60		
		2.9	2.16	7.5	15	15.0	—	15.0	36.1	54.5	60		
240-3-50	3.7	2.76	10.2	15	15.0	—	15.0	36.1	57.9	60			
	2.4	1.79	5.2	15	15.0	—	15.0	36.1	51.6	60			
	2.9	2.16	7.5	15	15.0	—	15.0	36.1	54.5	60			
5.0	3.73	15.2	15	15.0	—	15.0	36.1	64.1	70				
CAELHEAT008A00	40RM007-012 40RMS008-012	480-3-60	2.4	1.79	2.6	15	15.0	—	15.0	18.0	25.8	30	
			2.9	2.16	3.4	15	15.0	—	15.0	18.0	26.8	30	
			3.7	2.76	4.8	15	15.0	—	15.0	18.0	28.6	30	
400-3-50		2.4	1.79	2.6	15	10.4	—	10.4	15.0	22.0	25		
		2.9	2.16	3.4	15	10.4	—	10.4	15.0	23.0	25		
		5.0	3.73	7.6	15	10.4	—	10.4	15.0	28.3	30		
CAELHEAT009A00		40RM007-012 40RMS008-012	575-3-60	1.0	0.75	1.4	15	15.0	—	15.0	15.1	20.6	25
				2.0	1.49	2.3	15	15.0	—	15.0	15.1	21.7	25
				3.0	2.24	3.8	15	15.0	—	15.0	15.1	23.6	25

40RM/RMS

ELECTRIC HEATER DATA (cont)

HEATER PART NO.	UNIT	V-PH-Hz	FAN MOTOR			ELECTRIC HEATER(S)					MCA*	MOCP*
			Hp	kW	FLA	Nominal Capacity (kW)	Actual Capacity (kW)			FLA		
							Stage 1	Stage 2	Total			
CAELHEAT010A00	40RM007-012 40RMS008-012	208-3-60	1.3†	0.97	7.6	25	11.3	7.5	18.8	52.1	74.7	80
			2.4†	1.79	11.0	25	11.3	7.5	18.8	52.1	78.9	80
			2.4	1.79	5.2	25	11.3	7.5	18.8	52.1	71.7	80
			2.9	2.16	7.5	25	11.3	7.5	18.8	52.1	74.5	80
			3.7	2.76	10.2	25	11.3	7.5	18.8	52.1	77.9	80
		240-3-60	1.3†	0.97	7.6	25	15.0	10.0	25.0	60.1	84.7	90
			2.4†	1.79	11.0	25	15.0	10.0	25.0	60.1	88.9	90
			2.4	1.79	5.2	25	15.0	10.0	25.0	60.1	81.7	90
		240-3-50	2.9	2.16	7.5	25	15.0	10.0	25.0	60.1	84.6	90
			3.7	2.76	10.2	25	15.0	10.0	25.0	60.1	87.9	90
			2.4	1.79	5.2	25	15.0	10.0	25.0	60.1	81.7	90
		CAELHEAT011A00		480-3-60	2.4	1.79	2.6	25	15.0	10.0	25.0	30.1
2.9	2.16				3.4	25	15.0	10.0	25.0	30.1	41.8	50
3.7	2.76				4.8	25	15.0	10.0	25.0	30.1	43.6	50
400-3-50	2.4			1.79	2.6	25	10.4	6.9	17.4	25.1	34.6	25
	2.9			2.16	3.4	25	10.4	6.9	17.4	25.1	35.6	40
	5.0			3.73	7.6	25	10.4	6.9	17.4	25.1	40.8	50
CAELHEAT012A00	575-3-60	1.0	0.75	1.4	25	15.0	10.0	25.0	25.1	33.1	35	
		2.0	1.49	2.3	25	15.0	10.0	25.0	25.1	34.3	35	
		3.0	2.24	3.8	25	15.0	10.0	25.0	25.1	36.1	40	
CAELHEAT013A00	40RM008,012 40RMS008-012	208-3-60	2.4†	1.79	11.0	35	15.0	11.3	26.3	73.0	105.0	110
			2.4	1.79	5.2	35	15.0	11.3	26.3	73.0	97.7	100
			2.9	2.16	7.5	35	15.0	11.3	26.3	73.0	100.6	110
			3.7	2.76	10.2	35	15.0	11.3	26.3	73.0	104.0	110
		240-3-60	2.4†	1.79	11.0	35	20.0	15.0	35.0	84.2	119.0	125
			2.4	1.79	5.2	35	20.0	15.0	35.0	84.2	111.7	125
			2.9	2.16	7.5	35	20.0	15.0	35.0	84.2	114.6	125
			3.7	2.76	10.2	35	20.0	15.0	35.0	84.2	118.0	125
		240-3-50	2.4	1.79	5.2	35	20.0	15.0	35.0	84.2	111.7	125
			2.9	2.16	7.5	35	20.0	15.0	35.0	84.2	114.6	125
			5.0	3.73	15.2	35	20.0	15.0	35.0	84.2	124.2	125
			2.4	1.79	2.6	35	20.0	15.0	35.0	42.1	55.9	60
CAELHEAT014A00		480-3-60	2.9	2.16	3.4	35	20.0	15.0	35.0	42.1	56.9	60
			3.7	2.76	4.8	35	20.0	15.0	35.0	42.1	58.6	60
			2.4	1.79	2.6	35	13.9	10.4	24.3	35.1	47.1	50
		400-3-50	2.9	2.16	3.4	35	13.9	10.4	24.3	35.1	48.1	50
			5.0	3.73	7.6	35	13.9	10.4	24.3	35.1	53.4	60
			2.0	1.49	2.3	35	20.0	15.0	35.0	35.1	46.8	50
CAELHEAT015A00	575-3-60	3.0	2.24	3.8	35	20.0	15.0	35.0	35.1	48.7	50	
		3.0	2.24	3.8	35	20.0	15.0	35.0	35.1	48.7	50	

40RM/RMS

LEGEND

- FLA** — Full Load Amps
- Hp** — Horsepower
- MCA** — Minimum Circuit Amps
- MOCP** — Maximum Overcurrent Protection (Amps)

*Values shown are for single-point connection of electric heat accessory and air handler.

†Single-phase motors. All other motors are 3-phase.

NOTES:

1. Electrical resistance heaters are rated at 240 v, 480 v, or 575 v. To determine heater capacity (kW) at unit nameplate multiply the 240-v, 480-v, or 575-v capacity (kW) by the factor shown in the table below for the unit voltage.

HEATER RATING VOLTAGE	ACTUAL HEATER VOLTAGE										
	200	208	230	240	400	440	460	480	550	575	600
240	0.694	0.751	0.918	1	—	—	—	—	—	—	—
480	—	—	—	—	0.694	0.84	0.918	1	—	—	—
575	—	—	—	—	—	—	—	—	0.915	1	1.089

2. The following equation converts kW of heat energy to Btuh:
kW x 3,412 = Btuh.
3. Heater contactor coils are 24 v and require 8 va holding current.
4. Electric heaters are tested and ETL approved at maximum total external static pressure of 1.9 in. wg.
5. MCA and MOCP values apply to both standard and alternate factory-supplied motors.

Electrical data (cont)

ELECTRIC HEATER DATA (cont)

HEATER PART NO.	UNIT	V-PH-Hz	FAN MOTOR			ELECTRIC HEATER(S)					MCA*	MOCPS*
			Hp	kW	FLA	Nominal Capacity (kW)	Actual Capacity (kW)			FLA		
							Stage 1	Stage 2	Total			
CAELHEAT016A00	40RM014-024 40RMS014-024	208-3-60	2.9	2.16	7.5	10	7.5	—	7.5	20.8	35.4	40
			3.7	2.76	10.2	10	7.5	—	7.5	20.8	38.8	40
			5.0	3.73	15.3	10	7.5	—	7.5	20.8	45.1	50
			7.5	5.59	22.4	10	7.5	—	7.5	20.8	54.4	70
		240-3-60	2.9	2.16	7.5	10	10.0	—	10.0	24.1	39.4	40
			3.7	2.76	10.2	10	10.0	—	10.0	24.1	42.8	50
			5.0	3.73	12.8	10	10.0	—	10.0	24.1	46.1	50
			7.5	5.59	19.4	10	10.0	—	10.0	24.1	54.4	70
		240-3-50	2.9	2.16	7.5	10	10.0	—	10.0	24.1	39.4	40
			5.0	3.73	15.2	10	10.0	—	10.0	24.1	49.1	50
			7.5	5.59	22.8	10	10.0	—	10.0	24.1	58.6	70
			7.5	5.59	22.8	10	10.0	—	10.0	24.1	58.6	70
CAELHEAT017A00	40RM014-024 40RMS014-024	480-3-60	2.9	2.16	3.4	10	10.0	—	10.0	12.0	19.3	20
			3.7	2.76	4.8	10	10.0	—	10.0	12.0	21.0	25
			5.0	3.73	6.4	10	10.0	—	10.0	12.0	23.0	25
			7.5	5.59	9.7	10	10.0	—	10.0	12.0	27.2	30
		400-3-50	2.9	2.16	3.4	10	6.9	—	6.9	10.0	16.8	20
			5.0	3.73	7.6	10	6.9	—	6.9	10.0	22.0	25
CAELHEAT018A00	40RM014-024 40RMS014-024	575-3-60	3.0	2.24	3.8	10	10.0	—	10.0	10.0	17.3	20
			5.0	3.73	5.1	10	10.0	—	10.0	10.0	19.6	20
			7.5	5.59	7.8	10	10.0	—	10.0	10.0	22.1	25
			7.5	5.59	7.8	10	10.0	—	10.0	10.0	22.1	25
		208-3-60	2.9	2.16	7.5	20	15.0	—	15.0	41.7	61.5	70
			3.7	2.76	10.2	20	15.0	—	15.0	41.7	65.4	70
CAELHEAT019A00	40RM014-024 40RMS014-024	208-3-60	5.0	3.73	15.3	20	15.0	—	15.0	41.7	71.1	80
			7.5	5.59	22.4	20	15.0	—	15.0	41.7	79.6	90
			7.5	5.59	22.4	20	15.0	—	15.0	41.7	79.6	90
			7.5	5.59	22.4	20	15.0	—	15.0	41.7	79.6	90
		240-3-60	2.9	2.16	7.5	20	20.0	—	20.0	48.1	69.5	70
			3.7	2.76	10.2	20	20.0	—	20.0	48.1	73.4	80
			5.0	3.73	12.8	20	20.0	—	20.0	48.1	76.1	80
			7.5	5.59	19.4	20	20.0	—	20.0	48.1	84.4	90
		240-3-50	2.9	2.16	7.5	20	20.0	—	20.0	48.1	69.5	70
			5.0	3.73	15.2	20	20.0	—	20.0	48.1	79.1	80
			7.5	5.59	22.8	20	20.0	—	20.0	48.1	86.4	90
			7.5	5.59	22.8	20	20.0	—	20.0	48.1	86.4	90
CAELHEAT020A00	40RM014-024 40RMS014-024	480-3-60	2.9	2.16	3.4	20	20.0	—	20.0	24.1	34.3	35
			3.7	2.76	4.8	20	20.0	—	20.0	24.1	36.1	40
			5.0	3.73	6.4	20	20.0	—	20.0	24.1	39.1	40
			7.5	5.59	9.7	20	20.0	—	20.0	24.1	43.2	50
		400-3-50	2.9	2.16	3.4	20	13.9	—	13.9	20.0	29.3	30
			5.0	3.73	7.6	20	13.9	—	13.9	20.0	45.1	50
CAELHEAT021A00	40RM014-024 40RMS014-024	575-3-60	3.0	2.24	3.8	20	20.0	—	20.0	20.1	29.9	30
			5.0	3.73	5.1	20	20.0	—	20.0	20.1	31.5	35
			7.5	5.59	7.8	20	20.0	—	20.0	20.1	34.9	35
			7.5	5.59	7.8	20	20.0	—	20.0	20.1	34.9	35
		208-3-60	2.9	2.16	7.5	30	15.0	7.5	22.5	62.5	87.5	90
			3.7	2.76	10.2	30	15.0	7.5	22.5	62.5	90.9	100
CAELHEAT022A00	40RM014-024 40RMS014-024	208-3-60	5.0	3.73	15.3	30	15.0	7.5	22.5	62.5	97.2	100
			7.5	5.59	22.4	30	15.0	7.5	22.5	62.5	106.2	110
			7.5	5.59	22.4	30	15.0	7.5	22.5	62.5	106.2	110
			7.5	5.59	22.4	30	15.0	7.5	22.5	62.5	106.2	110
		240-3-60	2.9	2.16	7.5	30	20.0	10.0	30.0	72.2	99.6	100
			3.7	2.76	10.2	30	20.0	10.0	30.0	72.2	103.0	110
			5.0	3.73	12.8	30	20.0	10.0	30.0	72.2	106.2	110
			7.5	5.59	19.4	30	20.0	10.0	30.0	72.2	114.5	125
		240-3-50	2.9	2.16	7.5	30	20.0	10.0	30.0	72.2	99.6	100
			5.0	3.73	15.2	30	20.0	10.0	30.0	72.2	109.2	110
			7.5	5.59	22.8	30	20.0	10.0	30.0	72.2	118.7	125
			7.5	5.59	22.8	30	20.0	10.0	30.0	72.2	118.7	125
CAELHEAT023A00	40RM014-024 40RMS014-024	480-3-60	2.9	2.16	3.4	30	20.0	10.0	30.0	36.1	49.4	50
			3.7	2.76	4.8	30	20.0	10.0	30.0	36.1	51.1	60
			5.0	3.73	6.4	30	20.0	10.0	30.0	36.1	53.1	60
			7.5	5.59	9.7	30	20.0	10.0	30.0	36.1	57.2	60
		400-3-50	2.9	2.16	3.4	30	13.9	6.9	20.8	30.1	41.8	50
			5.0	3.73	7.6	30	13.9	7.9	20.8	30.1	47.1	50
CAELHEAT024A00	40RM014-024 40RMS014-024	575-3-60	7.5	5.59	11.4	30	13.9	7.9	20.8	30.1	51.8	60
			7.5	5.59	11.4	30	13.9	7.9	20.8	30.1	51.8	60
			7.5	5.59	11.4	30	13.9	7.9	20.8	30.1	51.8	60
			7.5	5.59	11.4	30	13.9	7.9	20.8	30.1	51.8	60
		208-3-60	3.0	2.24	3.8	30	20.0	10.0	30.0	30.1	42.4	50
			5.0	3.73	5.1	30	20.0	10.0	30.0	30.1	44.0	50
208-3-60	7.5	5.59	7.8	30	20.0	10.0	30.0	30.1	47.4	50		
	7.5	5.59	7.8	30	20.0	10.0	30.0	30.1	47.4	50		

40RM/RMS

ELECTRIC HEATER DATA (cont)

HEATER PART NO.	UNIT	V-PH-Hz	FAN MOTOR			ELECTRIC HEATER(S)					MCA*	MOCP*
			Hp	kW	FLA	Nominal Capacity (kW)	Actual Capacity (kW)			FLA		
							Stage 1	Stage 2	Total			
CAELHEAT025A00	40RM016,024 40RMS016,024	208-3-60	3.7	2.76	10.2	50	22.6	15.0	37.6	104.3	143.1	150
			5.0	3.73	15.3	50	22.6	15.0	37.6	104.3	149.5	150
			7.5	5.59	22.4	50	22.6	15.0	37.6	104.3	158.4	175
		240-3-60	3.7	2.76	10.2	50	30.0	20.0	50.0	120.3	163.1	175
			5.0	3.73	12.8	50	30.0	20.0	50.0	120.3	166.4	175
			7.5	5.59	19.4	50	30.0	20.0	50.0	120.3	174.6	200
		240-3-50	2.9	2.16	7.5	50	30.0	20.0	50.0	120.3	159.7	175
			5.0	3.73	15.2	50	30.0	20.0	50.0	120.3	169.4	175
			7.5	5.59	22.8	50	30.0	20.0	50.0	120.3	178.9	200
CAELHEAT026A00	40RM016,024 40RMS016,024	480-3-60	3.7	2.76	4.8	50	30.0	20.0	50.0	60.1	81.2	90
			5.0	3.73	6.4	50	30.0	20.0	50.0	60.1	83.2	90
			7.5	5.59	9.7	50	30.0	20.0	50.0	60.1	87.3	90
		400-3-50	2.9	2.16	3.4	50	20.8	13.9	34.7	50.1	66.9	70
			5.0	3.73	7.6	50	20.8	13.9	34.7	50.1	72.1	80
			7.5	5.59	11.4	50	20.8	13.9	34.7	50.1	76.9	80
CAELHEAT027A00	40RM016,024 40RMS016,024	575-3-60	3.0	2.24	3.8	50	30.0	20.0	50.0	50.2	67.5	70
			5.0	3.73	5.1	50	30.0	20.0	50.0	50.2	69.1	70
			7.5	5.59	7.8	50	30.0	20.0	50.0	50.2	72.5	80
CAELHEAT028A00	40RM028,034 40RMS028,034	208-3-60	7.5	5.59	22.4	20	15.0	—	15.0	41.7	80.1	90
			10.0	7.46	29.3	20	15.0	—	15.0	41.7	88.7	100
		240-3-60	7.5	5.59	19.4	20	20.0	—	20.0	48.1	84.3	90
			10.0	7.46	26.8	20	20.0	—	20.0	48.1	94.0	110
		240-3-50	7.5	5.59	22.8	20	20.0	—	20.0	48.1	88.6	90
			10.0	7.46	32.2	20	20.0	—	20.0	48.1	100.4	110
CAELHEAT029A00	40RM028,034 40RMS028,034	480-3-60	7.5	5.59	9.7	20	20.0	—	20.0	24.1	42.2	50
			10.0	7.46	13.4	20	20.0	—	20.0	24.1	46.8	50
		400-3-50	7.5	5.59	11.4	20	13.9	—	13.9	20.0	39.3	40
10.0	7.46		16.1	20	13.9	—	13.9	20.0	45.2	50		
CAELHEAT030A00	40RM028,034 40RMS028,034	575-3-60	7.5	5.59	7.8	20	20.0	—	20.0	20.1	34.9	35
			10.0	7.46	10.3	20	20.0	—	20.0	20.1	38.0	40
CAELHEAT031A00	40RM028,034 40RMS028,034	208-3-60	7.5	5.59	22.4	40	15.0	15.0	30.0	83.4	132.2	150
			10.0	7.46	29.3	40	15.0	15.0	30.0	83.4	140.9	150
		240-3-60	7.5	5.59	19.4	40	20.0	20.0	40.0	96.2	144.5	150
			10.0	7.46	26.8	40	20.0	20.0	40.0	96.2	153.8	175
CAELHEAT032A00	40RM028,034 40RMS028,034	240-3-50	7.5	5.59	22.8	40	20.0	20.0	40.0	96.2	148.8	150
			10.0	7.46	32.2	40	20.0	20.0	40.0	96.2	160.5	175
		480-3-60	7.5	5.59	9.7	40	20.0	20.0	40.0	48.1	72.3	80
10.0	7.46		13.4	40	20.0	20.0	40.0	48.1	76.9	80		
CAELHEAT033A00	40RM028,034 40RMS028,034	400-3-50	7.5	5.59	11.4	40	13.9	13.9	27.8	40.1	64.4	70
			10.0	7.46	16.1	40	13.9	13.9	27.8	40.1	70.2	80
CAELHEAT033A00	40RM028,034 40RMS028,034	575-3-60	7.5	5.59	7.8	40	20.0	20.0	40.0	40.2	60.0	60
			10.0	7.46	10.3	40	20.0	20.0	40.0	40.2	63.1	70

40RM/RMS

LEGEND

- FLA** — Full Load Amps
- Hp** — Horsepower
- MCA** — Minimum Circuit Amps
- MOCP** — Maximum Overcurrent Protection (Amps)

*Values shown are for single-point connection of electric heat accessory and air handler.

†Single-phase motors. All other motors are 3-phase.

NOTES:

1. Electrical resistance heaters are rated at 240 v, 480 v, or 575 v. To determine heater capacity (kW) at unit nameplate multiply the 240-v, 480-v, or 575-v capacity (kW) by the factor shown in the table below for the unit voltage.

HEATER RATING VOLTAGE	ACTUAL HEATER VOLTAGE										
	200	208	230	240	400	440	460	480	550	575	600
240	0.694	0.751	0.918	1	—	—	—	—	—	—	—
480	—	—	—	—	0.694	0.84	0.918	1	—	—	—
575	—	—	—	—	—	—	—	—	0.915	1	1.089

2. The following equation converts kW of heat energy to Btuh:
kW x 3,412 = Btuh.
3. Heater contactor coils are 24 v and require 8 va holding current.
4. Electric heaters are tested and ETL approved at maximum total external static pressure of 1.9 in. wg.
5. MCA and MOCP values apply to both standard and alternate factory-supplied motors.

Electrical data (cont)

ELECTRIC HEATER DATA (cont)

HEATER PART NO.	UNIT	V-PH-Hz	FAN MOTOR			ELECTRIC HEATER(S)					MCA*	MOCP*
			Hp	kW	FLA	Nominal Capacity (kW)	Actual Capacity (kW)			FLA		
							Stage 1	Stage 2	Total			
CAELHEAT034A00	40RM028,034 40RMS028,034	208-3-60	7.5 10.0	5.59 7.46	22.4 29.3	50 50	22.6 22.6	15.0 15.0	37.6 37.6	104.3 104.3	158.3 166.9	175 175
		240-3-60	7.5 10.0	5.59 7.46	19.4 26.8	50 50	30.0 30.0	20.0 20.0	50.0 50.0	120.3 120.3	174.6 183.9	200 200
		240-3-50	7.5 10.0	5.59 7.46	22.8 32.2	50 50	30.0 30.0	20.0 20.0	50.0 50.0	120.3 120.3	178.9 190.6	200 200
CAELHEAT035A00		480-3-60	7.5 10.0	5.59 7.46	9.7 13.4	50 50	30.0 30.0	20.0 20.0	50.0 50.0	60.1 60.1	87.3 91.9	90 100
		400-3-50	7.5 10.0	5.59 7.46	11.4 16.1	50 50	20.8 20.8	13.9 13.9	34.7 34.7	50.1 50.1	76.9 82.8	80 90
CAELHEAT036A00		575-3-60	7.5 10.0	5.59 7.46	7.8 10.3	50 50	30.0 30.0	20.0 20.0	50.0 50.0	50.2 50.2	72.5 75.6	80 80
CAELHEAT037A00		208-3-60	7.5 10.0	5.59 7.46	22.4 29.3	70 70	30.0 30.0	22.6 22.6	52.6 52.6	145.9 145.9	173.9 182.6	175 200
		240-3-60	7.5 10.0	5.59 7.46	19.4 26.8	70 70	40.0 40.0	30.0 30.0	70.0 70.0	168.4 168.4	192.6 201.9	200 225
		240-3-50	7.5 10.0	5.59 7.46	22.8 32.2	70 70	40.0 40.0	30.0 30.0	70.0 70.0	168.4 168.4	196.9 208.6	200 225
CAELHEAT038A00		480-3-60	7.5 10.0	5.59 7.46	9.7 13.4	70 70	40.0 40.0	30.0 30.0	70.0 70.0	84.2 84.2	96.3 100.9	100 110
		400-3-50	7.5 10.0	5.59 7.46	11.4 16.1	70 70	27.8 27.8	20.8 20.8	48.6 48.6	70.2 70.2	84.4 90.3	90 100
CAELHEAT039A00		575-3-60	7.5 10.0	5.59 7.46	7.8 10.3	70 70	40.0 40.0	30.0 30.0	70.0 70.0	70.3 70.3	80.0 83.2	90 90

LEGEND

- FLA** — Full Load Amps
Hp — Horsepower
MCA — Minimum Circuit Amps
MOCP — Maximum Overcurrent Protection (Amps)

*Values shown are for single-point connection of electric heat accessory and air handler.

†Single-phase motors. All other motors are 3-phase.

NOTES:

- Electrical resistance heaters are rated at 240 v, 480 v, or 575 v. To determine heater capacity (kW) at unit nameplate multiply the 240-v, 480-v, or 575-v capacity (kW) by the factor shown in the table below for the unit voltage.

HEATER RATING VOLTAGE	ACTUAL HEATER VOLTAGE										
	200	208	230	240	400	440	460	480	550	575	600
240	0.694	0.751	0.918	1	-	-	-	-	-	-	-
480	-	-	-	-	0.694	0.84	0.918	1	-	-	-
575	-	-	-	-	-	-	-	-	0.915	1	1.089

- The following equation converts kW of heat energy to Btuh:
 $\text{kW} \times 3,412 = \text{Btuh}$
- Heater contactor coils are 24 v and require 8 va holding current.
- Electric heaters are tested and ETL approved at maximum total external static pressure of 1.9 in. wg.
- MCA and MOCP values apply to both standard and alternate factory-supplied motors.

Typical piping and wiring

VERTICAL INSTALLATION - 40RM (TYPICAL)

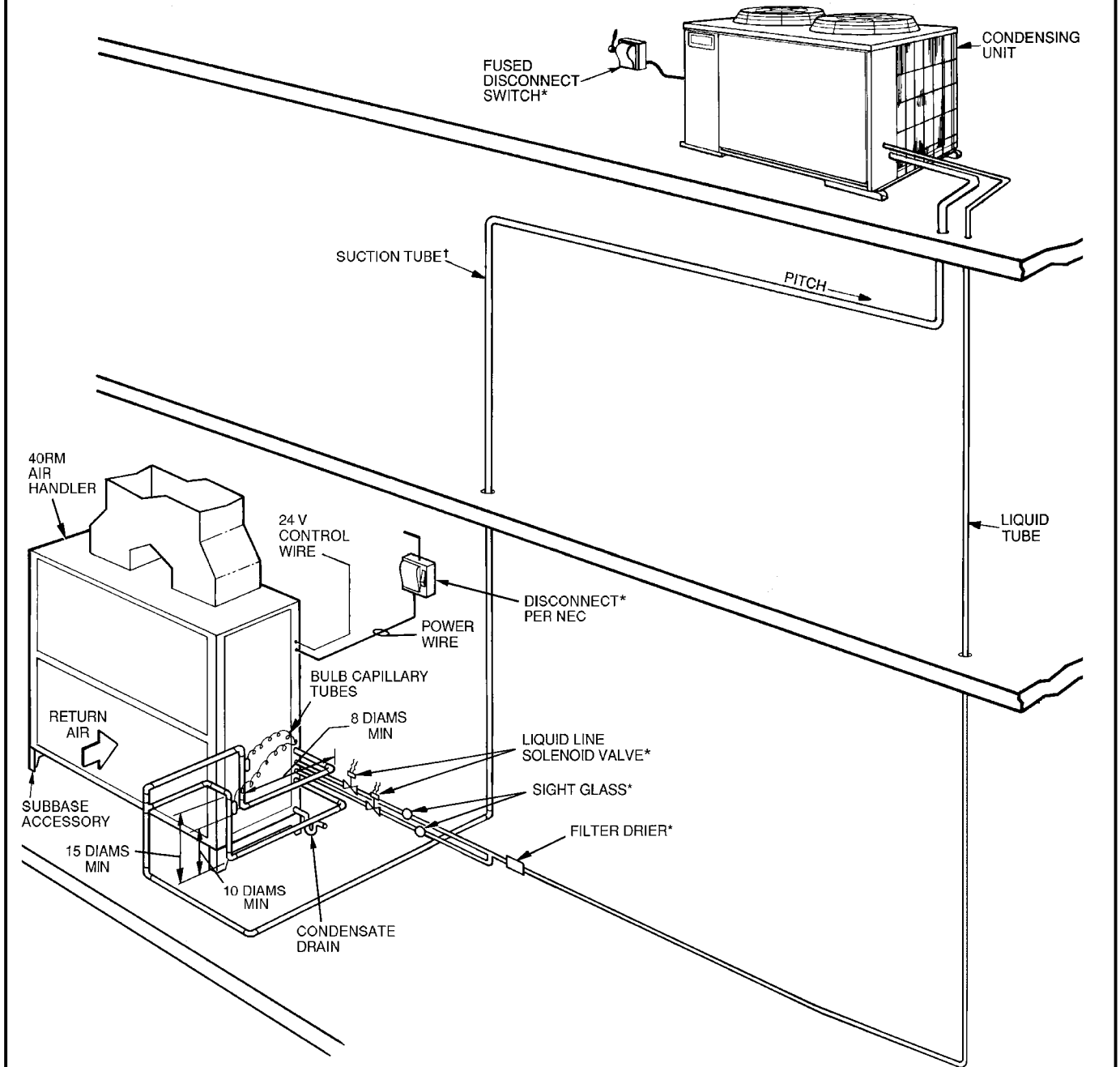

40RM/RMS

LEGEND

- NEC** - National Electrical Code
- TXV** - Thermostatic Expansion Valve
- Piping

*Field supplied.

²Double riser may be required. Consult condensing unit product data catalog for details.

NOTES:

1. All piping must follow standard refrigerant piping techniques. Refer to Carrier System Design Manual for details.
2. All wiring must comply with the applicable local and national codes.
3. Wiring and piping shown are general points-of-connection guides only and are not intended for, or to include all details for, a specific installation.
4. Liquid line solenoid valve (solenoid drop control) is recommended to prevent refrigerant migration to the compressor.
5. Internal factory-supplied TXVs not shown.

Typical piping and wiring (cont)

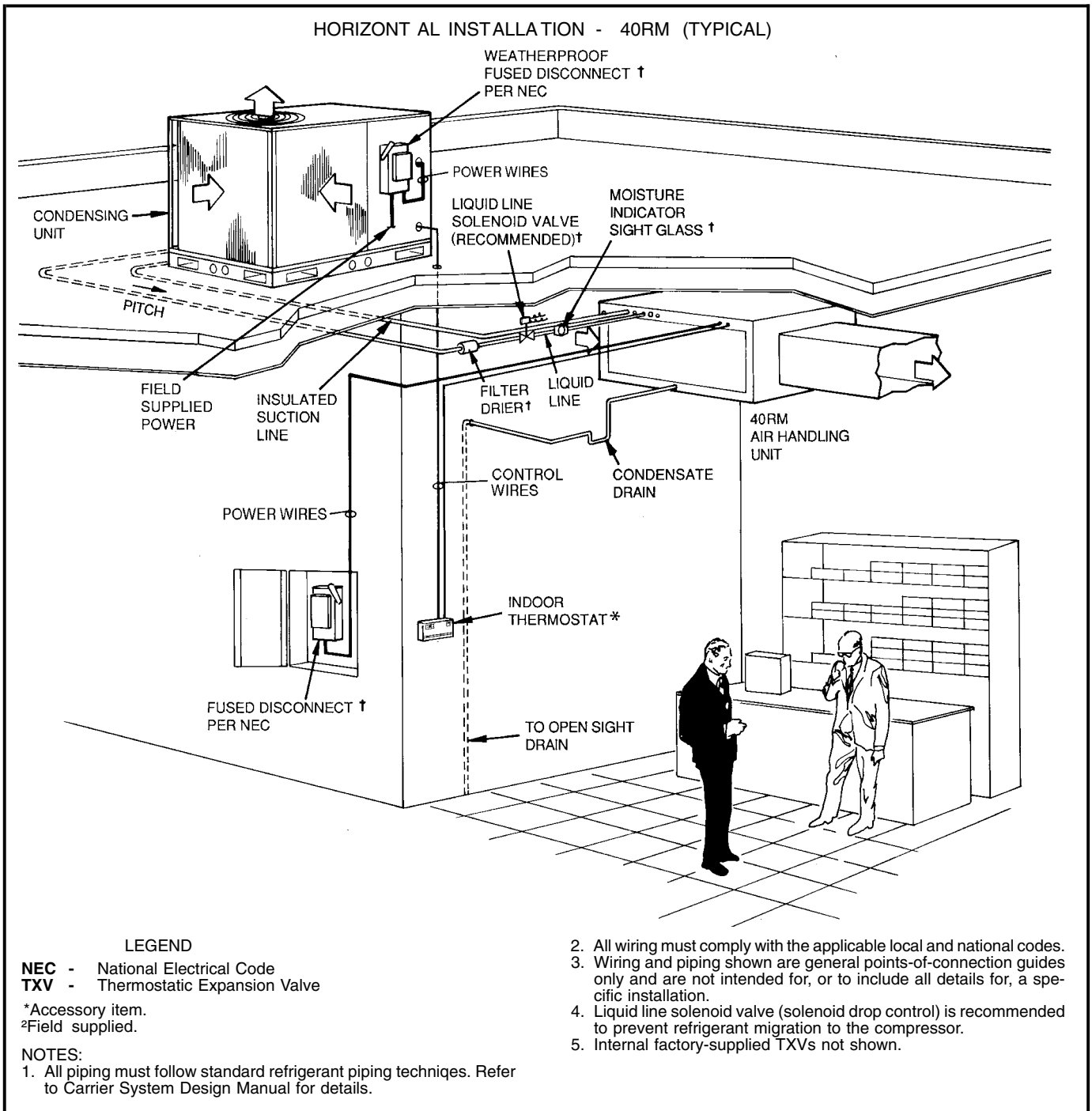

WIRE ROUTING, BASE UNIT - 40RM, 40RMS

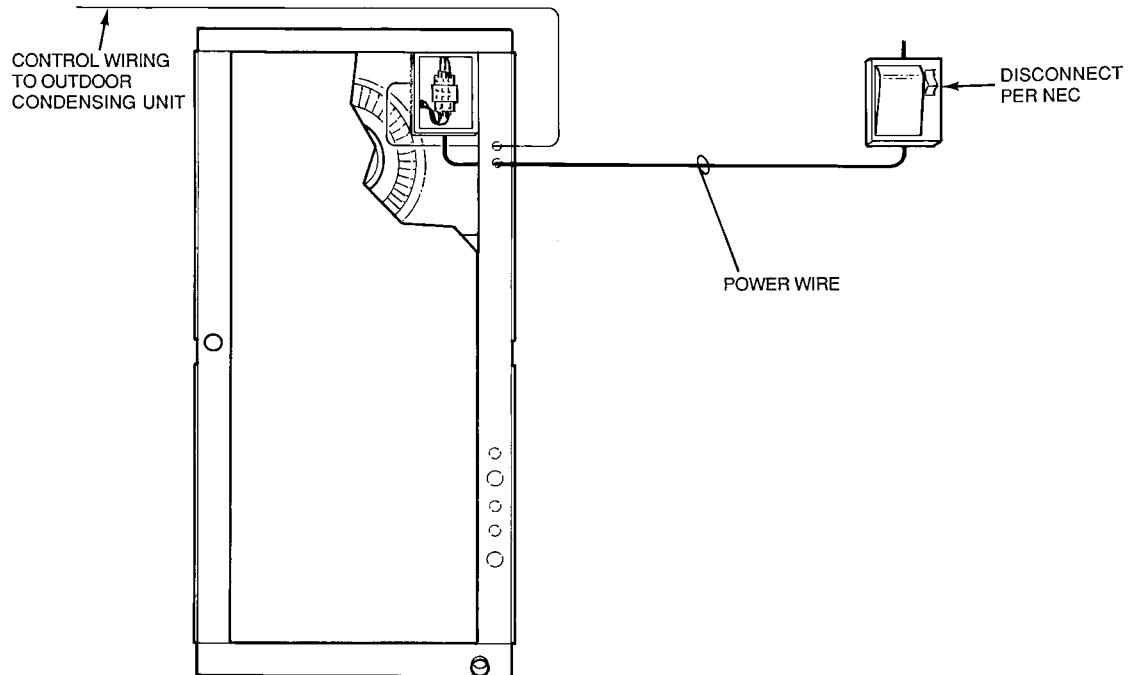

WIRE ROUTING, UNIT WITH ELECTRIC HEAT - 40RM, 40RMS

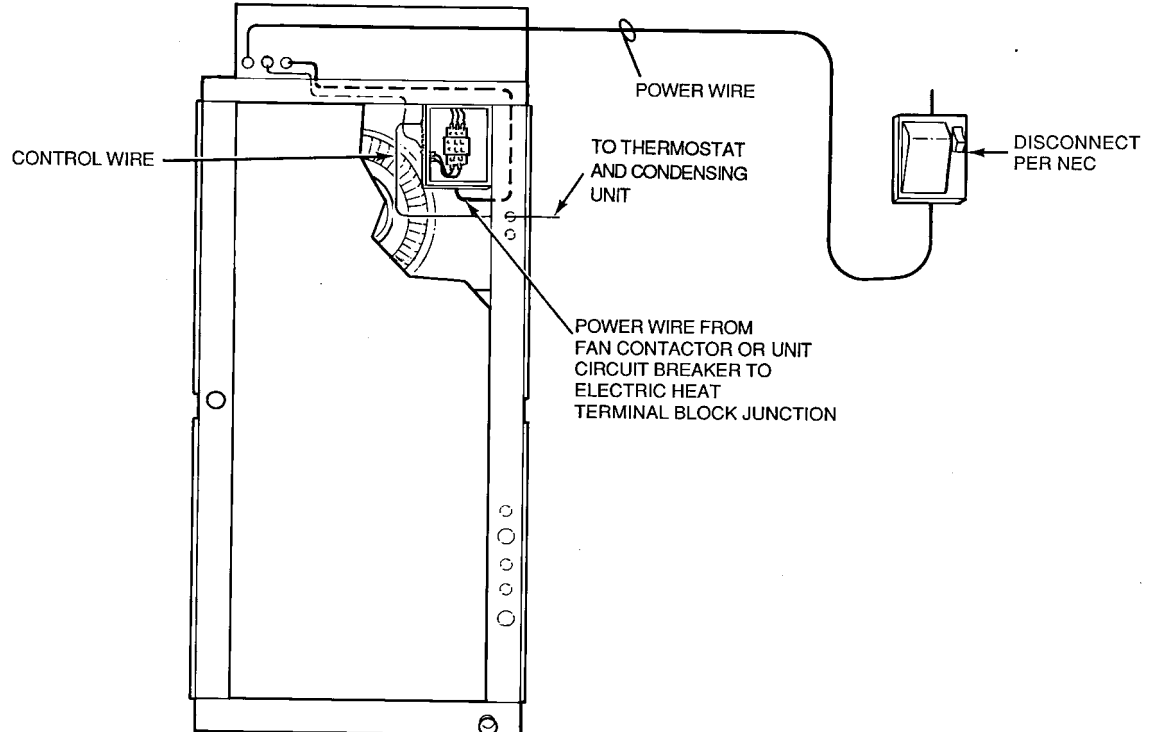

NEC - National Electrical Code

40RM/RMS

Typical piping and wiring (cont)

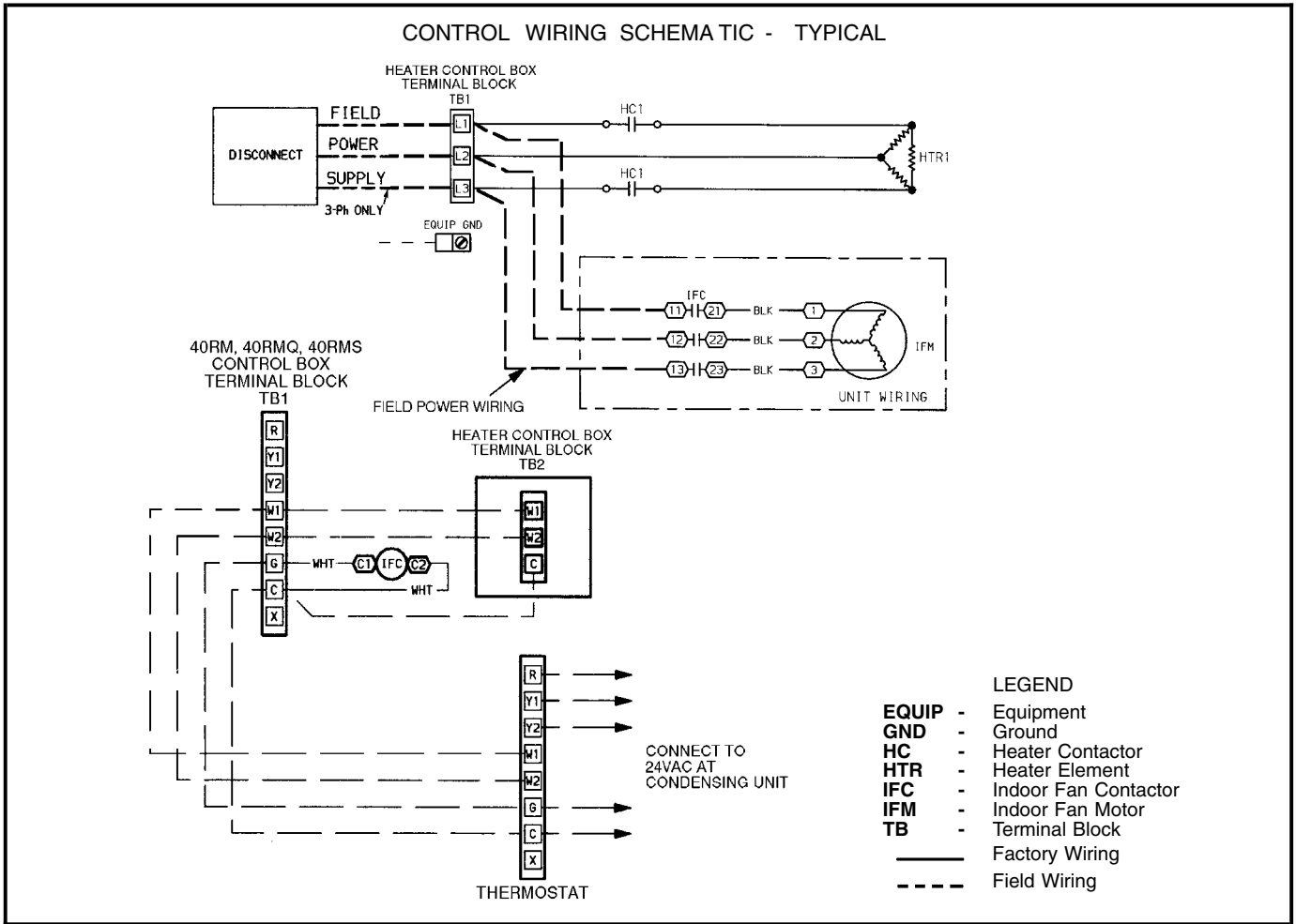

Application data

Operating limits

Maximum fan speed- 40RM007-024,
 40RMS008-024 1200 rpm (20 r/s)
 Maximum fan speed- 40RM and
 40RMS028,034 1100 rpm (18.3 r/s)

General

Select equipment to match or to be slightly less than peak load. This provides better humidity control, less unit cycling, and less part-load operation. Equipment should be selected to perform at no less than 300 cfm/ton (40 L/s per kW).

The air handler fan must always be operating when the condensing unit is operating.

Ductwork should be sized according to unit size, not building load. For larger units with two fans, a split duct transition is recommended at the fan outlets, but a plenum can be used with slight reduction in external static pressure capability.

For variable air volume (VAV) systems with supply-to-return air recycling, use the equipment room as a return air plenum.

FACTOR Y-INSTALLED NOZZLE AND DISTRIBUTOR DATA

UNIT	TXV Qty...Part No.*	DISTRIBUTOR Qty...Part No.*	FEEDER TUBES PER DISTRIBUTOR Qty...Size (in.)	NOZZLE Qty...Part No.
40RM007	1...XVE-5	1...1116	12... ^{1/4}	1...E5
40RM008	1...SVE-8	1...1126	15... ^{1/4}	1...C6
40RM012	2...XVE-4	2...1115	9... ^{1/4}	2...E4
40RM014	2...XVE-5	2...1115	9... ^{1/4}	2...E5
40RM016	2...XVE-8	2...1116	12... ^{1/4}	2...E6
40RM024	2...XVE-10	2...1116	13... ^{1/4}	2...E8
40RM028	2...EBSVE-11	2...1126	15... ^{1/4}	2...C10
40RM034	2...SVE-15	2...1126	18... ^{1/4}	2...C12

*Sporlan Valve Co. part numbers shown.

40RM/RMS

Application data (cont)

FAN MOTOR DATA STANDARD MOTOR - ENGLISH

UNIT	40RM 007	40RM 40RMS 008	40RMS 010	40RM 40RMS 012	40RM 40RMS 014	40RM 40RMS 016	40RM 40RMS 024	40RM 40RMS 028	40RM 40RMS 034
208/230-1-60									
Speed (rpm)	1725	1725	1725	-	-	-	-	-	-
Hp	1.3	2.4	2.4	-	-	-	-	-	-
Frame (NEMA)	56Y	56Y	56Y	-	-	-	-	-	-
Shaft Dia (in.)	5/8	5/8	5/8	-	-	-	-	-	-
208/230-3-60 and 460-3-60									
Speed (rpm)	1725	1725	1725	1725	1725	1725	1745	1745	1745
Hp	2.4	2.4	2.4	2.4	2.9	3.7	5.0	7.5	10.0
Frame (NEMA)	56Y	56Y	56Y	56Y	56Y	56Y	S184T	S213T	S215T
Shaft Dia (in.)	5/8	5/8	5/8	5/8	7/8	7/8	1 1/8	1 3/8	1 3/8
575-3-60									
Speed (rpm)	1725	1725	1725	1725	1725	1725	1745	1755	1755
Hp	1.0	2.0	2.0	2.0	3.0	3.0	5.0	7.5	10.0
Frame (NEMA)	56	56HZ	56HZ	56HZ	56HZ	56HZ	184T	S213T	D215T
Shaft Dia (in.)	5/8	7/8	7/8	7/8	7/8	7/8	1 1/8	1 3/8	1 3/8
230-3-50 and 400-3-50									
Speed (rpm)	1425	1425	1425	1425	1425	1425	1425	1425	1425
Hp	2.4	2.4	2.4	2.9	2.9	2.9	5.0	7.5	10.0
Frame (NEMA)	56Y	56Y	56Y	56Y	56Y	56Y	184T	S213T	S215T
Shaft Dia (in.)	5/8	5/8	5/8	7/8	7/8	7/8	1 1/8	1 3/8	1 3/8

NEMA - National Electrical Manufacturers Association (U.S.A.)

ALTERNATE MOTOR - ENGLISH

UNIT	40RM 007	40RM 40RMS 008	40RMS 010	40RM 40RMS 012	40RM 40RMS 014	40RM 40RMS 016	40RM 40RMS 024	40RM 40RMS 028
208/230-1-60								
Speed (rpm)	1725	1725	1725	-	-	-	-	-
Hp	2.4	2.4	2.4	-	-	-	-	-
Frame (NEMA)	56Y	56Y	56Y	-	-	-	-	-
Shaft Dia (in.)	5/8	7/8	7/8	-	-	-	-	-
208/230-3-60 and 460-3-60								
Speed (rpm)	1725	1725	1725	1725	1725	1725	1745	1745
Hp	2.9	2.9	2.9	3.7	3.7	5.0	7.5	10.0
Frame (NEMA)	56Y	56Y	56Y	Y56Y	Y56Y	S184T	S213T	S215T
Shaft Dia (in.)	7/8	7/8	7/8	7/8	7/8	1 1/8	1 3/8	1 3/8
575-3-60								
Speed (rpm)	1725	1725	1725	1725	1745	1745	1755	1750
Hp	2.0	3.0	3.0	3.0	5.0	5.0	7.5	10.0
Frame (NEMA)	56HZ	56HZ	56HZ	56HZ	184T	184T	S213T	D215T
Shaft Dia (in.)	7/8	7/8	7/8	7/8	1 1/8	1 1/8	1 3/8	1 3/8
230-3-50 and 400-3-50								
Speed (rpm)	1425	1425	1425	1425	1425	1425	1425	1425
Hp	2.4	2.9	2.9	5.0	5.0	5.0	7.5	10.0
Frame (NEMA)	56Y	56Y	56Y	S184T	S184T	S184T	S213T	S215T
Shaft Dia (in.)	7/8	7/8	7/8	7/8	1 1/8	1 1/8	1 3/8	1 3/8

NEMA - National Electrical Manufacturers Association (U.S.A.)

FAN MOTOR DRIVE (cont)

STANDARD MOTOR - SI

UNIT	40RM 007	40RM 40RMS 008	40RMS 010	40RM 40RMS 012	40RM 40RMS 014	40RM 40RMS 016	40RM 40RMS 024	40RM 40RMS 028	40RM 40RMS 034
208/230-1-60									
Speed (r/s)	28.75	28.75	28.75	-	-	-	-	-	-
Shaft kW	0.97	1.79	1.79	-	-	-	-	-	-
Frame (NEMA)	56Y	56Y	56Y	-	-	-	-	-	-
Shaft Dia (mm)	15.9	15.9	15.9	-	-	-	-	-	-
208/230-3-60 and 460-3-60									
Speed (r/s)	28.75	28.75	28.75	28.75	28.75	28.75	29.08	29.08	29.08
Shaft kW	1.79	1.79	1.79	1.79	2.16	2.76	3.73	5.60	7.46
Frame (NEMA)	56Y	56Y	56Y	56Y	56Y	56Y	S184T	S213T	S215T
Shaft Dia (mm)	15.9	15.9	15.9	15.9	22.2	22.2	28.6	34.9	34.9
575-3-60									
Speed (r/s)	28.75	28.75	28.75	28.75	28.75	28.75	29.08	29.25	29.25
Shaft kW	0.75	1.49	1.49	1.49	2.24	2.24	3.73	5.60	7.46
Frame (NEMA)	56	56HZ	56HZ	56HZ	56HZ	56HZ	184T	S213T	S215T
Shaft Dia (mm)	15.9	22.2	22.2	22.2	22.2	22.2	28.6	34.9	34.9
230-3-50 and 400-3-50									
Speed (r/s)	23.75	23.75	23.75	23.75	23.75	23.75	23.75	23.75	23.75
Shaft kW	1.79	1.79	1.79	2.16	2.16	2.16	3.73	5.60	7.46
Frame (NEMA)	56Y	56Y	56Y	56Y	56Y	56Y	184T	S213T	S215T
Shaft Dia (mm)	15.9	15.9	15.9	22.2	22.2	22.2	28.6	34.9	34.9

NEMA - National Electrical Manufacturers Association (U.S.A.)

ALTERNATE MOTOR - SI

UNIT	40RM 007	40RM 40RMS 008	40RMS 010	40RM 40RMS 012	40RM 40RMS 014	40RM 40RMS 016	40RM 40RMS 024	40RM 40RMS 028
208/230-1-60								
Speed (r/s)	28.75	28.75	28.75	-	-	-	-	-
Shaft kW	1.79	1.79	1.79	-	-	-	-	-
Frame (NEMA)	56Y	56Y	56Y	-	-	-	-	-
Shaft Dia (mm)	15.9	22.2	22.2	-	-	-	-	-
208/230-3-60 and 460-3-60								
Speed (r/s)	28.75	28.75	28.75	28.75	28.75	29.08	29.08	29.17
Shaft kW	2.16	2.16	2.16	2.76	2.76	3.73	5.60	7.46
Frame (NEMA)	56Y	56Y	56Y	Y56Y	Y56Y	S184T	S213T	S215T
Shaft Dia (mm)	22.2	22.2	22.2	22.2	22.2	28.6	34.9	34.9
575-3-60								
Speed (r/s)	28.75	28.75	28.75	28.75	29.08	29.08	29.25	29.17
Shaft kW	1.50	2.24	2.24	2.24	3.73	3.73	5.60	7.46
Frame (NEMA)	56HZ	56HZ	56HZ	56HZ	184T	184T	S213T	D215T
Shaft Dia (mm)	22.2	22.2	22.2	22.2	28.6	28.6	34.9	34.9
230-3-50 and 400-3-50								
Speed (r/s)	23.75	23.75	23.75	23.75	23.75	23.75	23.75	23.75
Shaft kW	1.79	2.16	2.16	3.73	3.73	3.73	5.60	7.46
Frame (NEMA)	56Y	56Y	56Y	S184T	S184T	S184T	S213T	S215T
Shaft Dia (mm)	22.2	22.2	22.2	22.2	28.6	28.6	34.9	34.9

NEMA - National Electrical Manufacturers Association (U.S.A.)

40RM/RMS

Application data (cont)

STANDARD DRIVE DATA, 60 Hz - ENGLISH

UNIT	40RM 007	40RM 40RMS 008	40RMS 010	40RM 40RMS 012	40RM 40RMS 014	40RM 40RMS 016	40RM 40RMS 024	40RM 40RMS 028	40RM 40RMS 034
MOTOR DRIVE									
Motor Pulley Pitch Diameter (in.)	2.4-3.4	2.8-3.8	2.8-3.8	3.4-4.4	2.8-3.8	2.8-3.8	3.7-4.7	4.3-5.3	4.3-5.3
Pulley Factory Setting Full Turns Open	2.5	2.5	2.5	2.5	2.5	2.5	3.0	3.0	3.0
FAN DRIVE									
Pulley Pitch Dia (in.)	8.8	8.8	8.8	8.8	9.0	9.0	9.4	11.0	11.0
Pulley Bore (in.)	1	1	1	1	1 7/16	1 7/16	1 7/16	1 15/16	1 15/16
Belt No. - Section	1-A	1-A	1-A	1-A	1-A	1-A	2-B	2-B*	2-B*
Belt Pitch (in.)	40.3	41.3	41.3	42.3	42.3	42.3	41.8	(2) 42.8 (2) 43.8	(2) 42.8 (2) 43.8
FAN SPEEDS (rpm)									
Factory Setting	568	647	647	764	632	632	771	752	752
Range	470-666	549-745	549-745	666-863	537-728	537-728	679-863	682-841	674-831
Max Allowable Speed (rpm)	1200	1200	1200	1200	1200	1200	1200	1100	1100
Change per 1/2 Turn of Moveable Motor Pulley Flange	19.6	19.6	19.6	19.7	19.1	19.1	15.3	13.1	13.1
MAX FULL TURNS FROM CLOSED POSITION	5	5	5	5	5	5	6	6	6
SHAFTS CENTER DISTANCE (in.)	10.44-12.32	10.44-12.32	10.44-12.32	10.44-12.32	10.44-12.32	10.44-12.32	9.12-10.99	6.67-9.43	6.67-9.43

*Four belts shipped with unit. Use correct set of 2 belts sized according to the pulley setting.

MEDIUM-STATIC DRIVE DATA, 60 Hz - ENGLISH

UNIT	40RM 007	40RM 40RMS 008	40RMS 010	40RM 40RMS 012	40RM 40RMS 014	40RM 40RMS 016	40RM 40RMS 024	40RM 40RMS 028	40RM 40RMS 034
MOTOR DRIVE									
Motor Pulley Pitch Diameter (in.)	3.4-4.4	3.4-4.4	3.4-4.4	3.4-4.4	3.4-4.4	3.7-4.7	4.3-5.3	4.3-5.3	4.3-5.3
Pulley Factory Setting Full Turns Open	2.5	2.5	2.5	2.5	2.5	3.0	3.0	3.0	3.0
FAN DRIVE									
Pulley Pitch Dia (in.)	8.8	8.0	8.0	8.0	8.2	8.6	9.4	9.4	9.4
Pulley Bore (in.)	1	1	1	1	1 7/16	1 7/16	1 7/16	1 15/16	1 15/16
Belt No. - Section	1-A	1-A	1-A	1-A	1-A	1-B	2-B	2-B*	2-B*
Belt Pitch (in.)	42.3	40.3	40.3	40.3	41.3	41.8	41.8	(2) 38.8 (2) 39.8	(2) 38.8 (2) 39.8
FAN SPEEDS (rpm)									
Factory Setting	764	841	841	841	820	842	881	881	881
Range	666-863	733-949	733-949	733-949	715-926	742-943	798-984	798-984	798-984
Max Allowable Speed (rpm)	1200	1200	1200	1200	1200	1200	1200	1100	1100
Change per 1/2 Turn of Moveable Motor Pulley Flange	19.7	21.6	21.6	21.6	21.1	16.7	15.3	15.3	15.3
MAX FULL TURNS FROM CLOSED POSITION	5	5	5	5	5	6	6	6	6
SHAFTS CENTER DISTANCE (in.)	10.44-12.32	10.44-12.32	10.44-12.32	10.44-12.32	10.44-12.32	10.44-12.32	9.16-10.99	6.67-9.43	6.67-9.43

*Four belts shipped with unit. Use correct set of 2 belts sized according to the pulley setting.

HIGH-STATIC DRIVE DATA, 60 Hz - ENGLISH

UNIT	40RM 007	40RM 40RMS 008	40RMS 010	40RM 40RMS 012	40RM 40RMS 014	40RM 40RMS 016	40RM 40RMS 024	40RM 40RMS 028	40RM 40RMS 034
MOTOR DRIVE									
Motor Pulley Pitch Diameter (in.)	3.4-4.4	3.4-4.4	3.4-4.4	3.4-4.4	3.7-4.7	4.3-5.3	4.3-5.3	4.3-5.3	4.3-5.3
Pulley Factory Setting Full Turns Open	2.5	2.5	2.5	2.5	3.0	3.0	3.0	3.0	3.0
FAN DRIVE									
Pulley Pitch Dia (in.)	7.0	6.0*	6.0	6.0	7.4	7.9	7.4	8.6	8.6
Pulley Bore (in.)	1	1	1	1	1 7/16	1 7/16	1 7/16	1 15/16	1 15/16
Belt No. - Section	1-A	1-A	1-A	1-A	1-B	1-B	2-B	2-B	2-B
Belt Pitch (in.)	41.3	37.3	37.3	37.3	39.8	39.8	36.8	37.8	37.8
FAN SPEEDS (rpm)									
Factory Setting	961	1121	1121	1121	979	1060	1118	1024	1024
Range	838-1084	978-1200*2	978-1200 ²	978-1200 ²	873-1096	950-1171	1014-1200 ²	873-1075	873-1075
Max Allowable Speed (rpm)	1200	1200	1200	1200	1200	1200	1200	1100	1100
Change per 1/2 Turn of Moveable Motor Pulley Flange	24.6	28.7	28.7	28.7	19.4	18.4	19.4	16.7	16.7
MAX FULL TURNS FROM CLOSED POSITION	5	5	5	5	6	6	6	6	6
SHAFTS CENTER DISTANCE (in.)	10.44-12.32	10.44-12.32	10.44-12.32	10.44-12.32	10.44-12.32**	9.16-10.99	8.16-10.02	6.67-9.43	6.67-9.43

*Values for 3-phase motor shown. For single-phase motor, pulley pitch diameter is 7 in. and resulting fan speed is 837-1096 rpm.

²It is possible to adjust drive so that fan speed exceeds maximum allowable. DO NOT exceed 1200 rpm.

**575-v unit has a center distance of 9.16-10.99.

STANDARD DRIVE DATA, 50 Hz - ENGLISH

UNIT	40RM 007	40RM 40RMS 008	40RMS 010	40RM 40RMS 012	40RM 40RMS 014	40RM 40RMS 016	40RM 40RMS 024	40RM 40RMS 028	40RM 40RMS 034
MOTOR DRIVE									
Motor Pulley Pitch Diameter (in.)	2.4-3.4	2.8-3.8	2.8-3.8	3.4-4.4	3.4-4.4	3.4-4.4	4.3-5.3	4.3-5.3	4.3-5.3
Pulley Factory Setting Full Turns Open	2.5	2.5	2.5	2.5	2.5	2.5	3.0	3.0	3.0
FAN DRIVE									
Pulley Pitch Dia (in.)	8.0	8.0	8.0	8.0	9.0	9.0	8.6	11.0	11.0
Pulley Bore (in.)	1	1	1	1	1 7/16	1 7/16	1 7/16	1 15/16	1 15/16
Belt No. - Section	1-A	1-A	1-A	1-A	1-A	1-A	1-B	2-B	2-B
Belt Pitch (in.)	39.3	39.3	39.3	40.3	42.3	42.3	41.8	43.8	43.8
FAN SPEEDS (rpm)									
Factory Setting	517	588	588	695	618	618	795	622	622
Range	428-606	499-677	449-677	606-784	538-697	538-697	713-878	557-687	557-687
Max Allowable Speed (rpm)	1200	1200	1200	1200	1200	1200	1200	1100	1100
Change per 1/2 Turn of Moveable Motor Pulley Flange	17.8	17.8	17.8	17.8	15.9	15.9	13.8	10.8	10.8
MAX FULL TURNS FROM CLOSED POSITION	5	5	5	5	5	5	6	6	6
SHAFTS CENTER DISTANCE (in.)	10.44-12.32	10.44-12.32	10.44-12.32	10.44-12.32	10.44-12.32	10.44-12.32	9.12-10.99	6.67-9.43	6.67-9.43

40RM/RMS

Application data (cont)

MEDIUM-STATIC DRIVE DATA, 50 Hz - ENGLISH

UNIT	40RM 007	40RM 40RMS 008	40RMS 010	40RM 40RMS 012	40RM 40RMS 014	40RM 40RMS 016	40RM 40RMS 024	40RM 40RMS 028	40RM 40RMS 034
MOTOR DRIVE									
Motor Pulley Pitch Diameter (in.)	3.4-4.4	3.4-4.4	3.4-4.4	3.4-4.4	3.4-4.4	3.7-4.7	4.0-5.0	4.3-5.3	4.3-5.3
Pulley Factory Setting Full Turns Open	2.5	2.5	2.5	2.5	2.5	3.0	2.5	3.0	3.0
FAN DRIVE									
Pulley Pitch Dia (in.)	8.0	7.0	7.0	6.0	7.5	7.9	7.0	9.4	9.4
Pulley Bore (in.)	1	1	1	1	1 7/16	1 7/16	1 7/16	1 15/16	1 15/16
Belt No. - Section	1-A	1-A	1-A	1-A	1-A	1-B	2-A	2-B	2-B
Belt Pitch (in.)	40.3	41.3	41.3	37.3	39.3	39.8	36.8	39.8	39.8
FAN SPEEDS (rpm)									
Factory Setting	695	794	794	926	741	756	916	728	728
Range	606-784	692-896	692-896	808-1045	646-836	667-848	814-1018	652-803	652-803
Max Allowable Speed (rpm)	1200	1200	1200	1200	1200	1200	1200	1100	1100
Change per 1/2 Turn of Moveable Motor Pulley Flange	17.8	20.4	20.4	23.7	19.0	15.1	20.4	12.6	12.6
MAX FULL TURNS FROM CLOSED POSITION	5	5	5	5	5	6	5	6	6
SHAFTS CENTER DISTANCE (in.)	10.44-12.32	10.44-12.32	10.44-12.32	10.44-12.32	10.44-12.32	9.16-10.99	9.16-10.99	6.67-9.43	6.67-9.43

HIGH-STATIC DRIVE DATA, 50 Hz - ENGLISH

UNIT	40RM 007	40RM 40RMS 008	40RMS 010	40RM 40RMS 012	40RM 40RMS 014	40RM 40RMS 016	40RM 40RMS 024	40RM 40RMS 028	40RM 40RMS 034
MOTOR DRIVE									
Motor Pulley Pitch Diameter (in.)	3.4-4.4	3.4-4.4	3.4-4.4	4.0-5.0	3.4-4.4	4.0-5.0	4.0-5.0	4.3-5.3	4.3-5.3
Pulley Factory Setting Full Turns Open	2.5	2.5	2.5	3.0	2.5	3.0	3.0	3.0	3.0
FAN DRIVE									
Pulley Pitch Dia (in.)	6.0	5.5	5.5	5.5	6.0	7.0	6.4	8.0	8.6
Pulley Bore (in.)	1	1	1	1	1 7/16	1 7/16	1 7/16	1 15/16	1 15/16
Belt No. - Section	1-A	1-A	1-A	1-A	2-A	2-A	2-A	2-B	2-B
Belt Pitch (in.)	37.3	37.3	37.3	36.3	36.3	39.3	34.3	36.8	37.8
FAN SPEEDS (rpm)									
Factory Setting	926	1010	1010	1166	926	916	1002	855	795
Range	808-1045	881-1140	881-1140	1036-1200*	808-1045	814-1018	891-1113	766-944	713-878
Max Allowable Speed (rpm)	1200	1200	1200	1200	1200	1200	1200	1100	1100
Change per 1/2 Turn of Moveable Motor Pulley Flange	23.7	25.9	25.9	21.6	23.7	17.0	18.5	14.8	13.8
MAX FULL TURNS FROM CLOSED POSITION	5	5	5	6	5	6	6	6	6
SHAFTS CENTER DISTANCE (in.)	10.44-12.32	10.44-12.32	10.44-12.32	9.16-10.99	9.16-10.99	9.16-10.99	8.16-10.02	6.67-9.43	6.67-9.43

*It is possible to adjust drive so that fan speed exceeds maximum allowable. DO NOT exceed 1200 rpm.

STANDARD DRIVE DATA, 60 Hz - SI

UNIT	40RM 007	40RM 40RMS 008	40RMS 010	40RM 40RMS 012	40RM 40RMS 014	40RM 40RMS 016	40RM 40RMS 024	40RM 40RMS 028	40RM 40RMS 034
MOTOR DRIVE									
Motor Pulley Pitch Diameter (mm)	61.0-86.4	71.1-96.5	71.1-96.5	86.4-111.8	71.1-96.5	71.1-96.5	94.0-119.4	109.2-134.6	109.2-134.6
Pulley Factory Setting Full Turns Open	2.5	2.5	2.5	2.5	2.5	2.5	3.0	3.0	3.0
FAN DRIVE									
Pulley Pitch Dia (mm)	224	224	224	224	229	229	239	279	279
Pulley Bore (mm)	25.4	25.4	25.4	25.4	36.5	36.5	36.5	49.2	49.2
Belt No. - Section	1-A	1-A	1-A	1-A	1-A	1-A	2-B	2-B*	2-B*
Belt Pitch (mm)	1024	1049	1049	1074	1074	1074	1062	(2) 1087 (2) 1113	(2) 1087 (2) 1113
FAN SPEEDS (r/s)									
Factory Setting	9.5	10.8	10.8	12.7	10.5	10.5	12.9	12.5	12.5
Range	7.8-11.1	9.2-12.4	9.2-12.4	11.1-14.4	9.0-12.1	9.0-12.1	11.3-14.4	11.4-14.0	11.2-13.9
Max Allowable Speed (r/s)	20.0	20.0	20.0	20.0	20.0	20.0	20.0	18.3	18.3
Change per 1/2 Turn of Moveable Motor Pulley Flange	0.327	0.327	0.327	0.328	0.318	0.318	0.255	0.218	0.218
MAX FULL TURNS FROM CLOSED POSITION	5	5	5	5	5	5	6	6	6
SHAFTS CENTER DISTANCE (mm)	265-313	265-313	265-313	265-313	265-313	265-313	232-279	169-240	169-240

*Four belts shipped with unit. Use correct set of 2 belts sized according to the pulley setting.

MEDIUM-STATIC DRIVE DATA, 60 Hz - SI

UNIT	40RM 007	40RM 40RMS 008	40RMS 010	40RM 40RMS 012	40RM 40RMS 014	40RM 40RMS 016	40RM 40RMS 024	40RM 40RMS 028	40RM 40RMS 034
MOTOR DRIVE									
Motor Pulley Pitch Diameter (mm)	86.4-111.8	86.4-111.8	86.4-111.8	86.4-111.8	86.4-111.8	94.0-119.4	109.2-134.6	109.2-134.6	109.2-134.6
Pulley Factory Setting Full Turns Open	2.5	2.5	2.5	2.5	2.5	3.0	3.0	3.0	3.0
FAN DRIVE									
Pulley Pitch Dia (mm)	224	203	203	203	208	218	239	239	239
Pulley Bore (mm)	25.4	25.4	25.4	25.4	36.5	36.5	36.5	49.2	49.2
Belt No. - Section	1-A	1-A	1-A	1-A	1-A	1-B	2-B	2-B*	2-B*
Belt Pitch (mm)	1074	1024	1024	1024	1049	1062	1062	(2) 986 (2) 1011	(2) 986 (2) 1011
FAN SPEEDS (r/s)									
Factory Setting	12.7	14.0	14.0	14.0	13.7	14.0	14.7	14.7	14.7
Range	11.1-14.4	12.2-15.8	12.2-15.8	12.2-15.8	11.9-15.4	12.4-15.7	13.3-16.4	13.3-16.4	13.3-16.4
Max Allowable Speed (r/s)	20.0	20.0	20.0	20.0	20.0	20.0	20.0	18.3	18.3
Change per 1/2 Turn of Moveable Motor Pulley Flange	0.328	0.360	0.360	0.360	0.352	0.278	0.255	0.255	0.255
MAX FULL TURNS FROM CLOSED POSITION	5	5	5	5	5	6	6	6	6
SHAFTS CENTER DISTANCE (mm)	265-313	265-313	265-313	265-313	265-313	265-313	232-279	169-240	169-240

*Four belts shipped with unit. Use correct set of 2 belts sized according to the pulley setting.

40RM/RMS

Application data (cont)

HIGH-STATIC DRIVE DATA, 60 Hz - SI

UNIT	40RM 007	40RM 40RMS 008	40RMS 010	40RM 40RMS 012	40RM 40RMS 014	40RM 40RMS 016	40RM 40RMS 024	40RM 40RMS 028	40RM 40RMS 034
MOTOR DRIVE									
Motor Pulley Pitch Diameter (mm)	86.4-111.8	86.4-111.8	86.4-111.8	86.4-111.8	94.0-119.4	109.2-134.6	109.2-134.6	109.2-134.6	109.2-134.6
Pulley Factory Setting Full Turns Open	2.5	2.5	2.5	2.5	3.0	3.0	3.0	3.0	3.0
FAN DRIVE									
Pulley Pitch Dia (mm)	178	152*	152	152	188	201	188	203	203
Pulley Bore (mm)	25.4	25.4	25.4	25.4	36.5	36.5	36.5	49.2	49.2
Belt No. - Section	1-A	1-A	1-A	1-A	1-B	1-B	2-B	2-B	2-B
Belt Pitch (mm)	1049	947	947	947	1011	1011	935	935	960
FAN SPEEDS (r/s)									
Factory Setting	16.0	18.7	18.7	18.7	16.3	17.7	18.6	17.1	17.1
Range	14.0-18.1	16.3-20.0*2	16.3-20.0 ²	16.3-20.0 ²	14.4-18.3	15.8-19.5	16.9-20.0 ²	14.6-17.9	14.6-17.9
Max Allowable Speed (r/s)	20.0	20.0	20.0	20.0	20.0	20.0	20.0	18.3	18.3
Change per 1/2 Turn of Moveable Motor Pulley Flange	0.410	0.478	0.478	0.478	0.323	0.307	0.323	0.278	0.278
MAX FULL TURNS FROM CLOSED POSITION	5	5	5	5	6	6	6	6	6
SHAFTS CENTER DISTANCE (mm)	265-313	265-313	265-313	265-313	265-313**	232-279	207-255	169-240	169-240

*Values for 3-phase motor shown. For single-phase motor, pulley pitch diameter is 178 mm and resulting fan speed is 14.0-18.3 r/s.

²It is possible to adjust drive so that fan speed exceeds maximum allowable. DO NOT exceed 20 r/s.

**575-v unit has a center distance of 233-279.

STANDARD DRIVE DATA, 50 Hz - SI

UNIT	40RM 007	40RM 40RMS 008	40RMS 010	40RM 40RMS 012	40RM 40RMS 014	40RM 40RMS 016	40RM 40RMS 024	40RM 40RMS 028	40RM 40RMS 034
MOTOR DRIVE									
Motor Pulley Pitch Diameter (mm)	61.0-86.4	71.1-96.5	71.1-96.5	86.4-111.8	86.4-111.8	86.4-111.8	109.2-134.6	109.2-134.6	109.2-134.6
Pulley Factory Setting Full Turns Open	2.5	2.5	2.5	2.5	2.5	2.5	3.0	3.0	3.0
FAN DRIVE									
Pulley Pitch Dia (mm)	203	203	203	203	229	229	218	279	279
Pulley Bore (mm)	25.4	25.4	25.4	25.4	36.5	36.5	36.5	49.2	49.2
Belt No. - Section	1-A	1-A	1-A	1-A	1-A	1-A	1-B	2-B	2-B
Belt Pitch (mm)	998	998	998	1024	1074	1074	1062	1113	1113
FAN SPEEDS (r/s)									
Factory Setting	8.6	9.8	9.8	11.6	10.3	10.3	13.3	10.4	10.4
Range	7.1-10.1	8.3-11.3	8.3-11.3	10.1-13.1	9.0-11.6	9.0-11.6	11.9-14.6	9.3-11.5	9.3-11.5
Max Allowable Speed (r/s)	20.0	20.0	20.0	20.0	20.0	20.0	20.0	18.3	18.3
Change per 1/2 Turn of Moveable Motor Pulley Flange	0.297	0.297	0.297	0.297	0.265	0.265	0.230	0.180	0.180
MAX FULL TURNS FROM CLOSED POSITION	5	5	5	5	5	5	6	6	6
SHAFTS CENTER DISTANCE (mm)	265-313	265-313	265-313	265-313	265-313	265-313	232-279	169-240	169-240

MEDIUM-STATIC DRIVE DATA, 50 Hz - SI

UNIT	40RM 007	40RM 40RMS 008	40RMS 010	40RM 40RMS 012	40RM 40RMS 014	40RM 40RMS 016	40RM 40RMS 024	40RM 40RMS 028	40RM 40RMS 034
MOTOR DRIVE									
Motor Pulley Pitch Diameter (mm)	86.4-111.8	86.4-111.8	86.4-111.8	86.4-111.8	86.4-111.8	94.0-119.4	101.6-127.0	109.2-134.6	109.2-134.6
Pulley Factory Setting Full Turns Open	2.5	2.5	2.5	2.5	2.5	3.0	2.5	3.0	3.0
FAN DRIVE									
Pulley Pitch Dia (mm)	203	178	178	152	191	201	178	239	239
Pulley Bore (mm)	25.4	25.4	25.4	25.4	36.5	36.5	36.5	49.2	49.2
Belt No. - Section	1-A	1-A	1-A	1-A	1-A	1-B	2-A	2-B	2-B
Belt Pitch (mm)	1024	1049	1049	947	998	1011	922	1011	1011
FAN SPEEDS (r/s)									
Factory Setting	11.6	13.2	13.2	15.4	12.4	12.6	15.3	12.1	12.1
Range	10.1-13.1	11.5-14.9	11.5-14.9	13.5-17.4	10.8-13.9	11.1-14.1	13.6-17.0	10.9-13.4	10.9-13.4
Max Allowable Speed (r/s)	20.0	20.0	20.0	20.0	20.0	20.0	20.0	18.3	18.3
Change per 1/2 Turn of Moveable Motor Pulley Flange	0.297	0.340	0.340	0.395	0.317	0.252	0.340	0.210	0.210
MAX FULL TURNS FROM CLOSED POSITION	5	5	5	5	5	6	5	6	6
SHAFTS CENTER DISTANCE (mm)	265-313	265-313	265-313	265-313	265-313	232-279	232-279	169-240	169-240

HIGH-STATIC DRIVE DATA, 50 Hz - SI

UNIT	40RM 007	40RM 40RMS 008	40RMS 010	40RM 40RMS 012	40RM 40RMS 014	40RM 40RMS 016	40RM 40RMS 024	40RM 40RMS 028	40RM 40RMS 034
MOTOR DRIVE									
Motor Pulley Pitch Diameter (mm)	86.4-111.8	86.4-111.8	86.4-111.8	101.6-127.0	86.4-111.8	101.6-127.0	101.6-127.0	109.2-134.6	109.2-134.6
Pulley Factory Setting Full Turns Open	2.5	2.5	2.5	3.0	2.5	3.0	3.0	3.0	3.0
FAN DRIVE									
Pulley Pitch Dia (mm)	152	140	140	140	152	178	163	203	218
Pulley Bore (mm)	25.4	25.4	25.4	25.4	36.5	36.5	36.5	49.2	49.2
Belt No. - Section	1-A	1-A	1-A	1-A	2-A	2-A	2-A	2-B	2-B
Belt Pitch (mm)	947	947	947	922	922	998	871	935	960
FAN SPEEDS (r/s)									
Factory Setting	15.4	16.8	16.8	19.4	15.4	15.3	16.7	14.3	13.3
Range	13.5-17.4	14.7-19.0	14.7-19.0	17.3-20.0*	13.5-17.4	13.6-17.0	14.9-18.6	12.8-15.7	11.9-14.6
Max Allowable Speed (r/s)	20.0	20.0	20.0	20.0	20.0	20.0	20.0	18.3	18.3
Change per 1/2 Turn of Moveable Motor Pulley Flange	0.395	0.432	0.432	0.360	0.395	0.283	0.308	0.247	0.230
MAX FULL TURNS FROM CLOSED POSITION	5	5	5	6	5	6	6	6	6
SHAFTS CENTER DISTANCE (mm)	265-313	265-313	265-313	234-279	232-279	232-279	207-255	169-240	169-240

*It is possible to adjust drive so that fan speed exceeds maximum allowable. DO NOT exceed 20 r/s.

40RM/RMS

Guide specifications

Commercial Packaged Air-Handling Unit

HVAC Guide Specifications

Size Range: 2,400 to 12,000 CFM (1150 to 5650 L/s),
Nominal Airflow 6 to 30 Tons (21 to 105 kW), Nominal Cooling

Carrier Model Numbers: 40RM (Direct-Expansion Coil)
40RMS (Chilled Water Coil)

Part 1 - GENERAL

1.01 SYSTEM DESCRIPTION

- A. Indoor, packaged air-handling unit for use in commercial split systems. Unit shall have a multiposition design and shall be capable of horizontal or vertical installation on a floor or in a ceiling, with or without ductwork. (Only vertical units are to be applied without ductwork.)
- B. Unit with direct-expansion coil shall be used in a refrigerant circuit with a matching air-cooled condensing unit. Unit with chilled water coil shall be used in a chilled water circuit.

1.02 QUALITY ASSURANCE

- A. Coils shall be designed & tested in accordance with ASHRAE 15 Safety Code for Mechanical Refrigeration (U.S.A.), latest edition.
- B. Unit shall be constructed in accordance with ETL (U.S.A.) and ETL, Canada, standards and shall carry the ETL and ETL, Canada, labels.
- C. Unit insulation and adhesive shall comply with NFPA-90A (U.S.A.) requirements for flame spread and smoke generation.
- D. Unit shall be manufactured in a facility registered to the ISO 9002 manufacturing quality standard.
- E. Direct-expansion and chilled water coils shall be burst and leak tested at 435 psi (2999 kPa).

1.03 DELIVERY AND STORAGE

Units shall be stored and handled per manufacturer's recommendations.

Part 2 - Products

2.01 EQUIPMENT

Indoor mounted, draw-thru, packaged air-handling unit that can be used in a suspended horizontal configuration or a vertical configuration. Unit shall consist of forward-curved belt-driven centrifugal fan(s), motor & drive assembly, prewired fan motor contactor, factory-installed refrigerant metering devices (direct-expansion coil units), cooling coil, 1-in. (25.4-mm) washable air filters, and condensate drain pans for vertical or horizontal configurations.

A. Base Unit (Painted):

1. Cabinet shall be constructed of zinc coated steel and polyester powder painted to protect them from corrosion in the harsh Middle Eastern climate and also to increase the colour life in high ultra-violet (UV) radiation regions.
2. Cabinet panels shall be fully insulated with 1/2 in. (12.7-mm) fire-retardant material.
3. Unit shall contain PVC condensate drain pans for both vertical and horizontal applications. Drain pans shall have connections on right and left sides of unit to facilitate field connection. Drain pans shall have the ability to be sloped toward the right or left side of the unit to prevent standing water from accumulating in pans.
4. Unit shall have factory-supplied 1-in. (25.4 mm) washable-type filters installed upstream from the cooling coil. Filter access shall be from the front of the unit.

B. Coils:

Coils shall consist of 3 rows (40RM, 40RMS), of copper tubes with sine-wave aluminum fins bonded to the tubes by mechanical expansion. Suction and liquid line connections or supply and discharge connections shall be made on the same side of the coil.

1. Direct-expansion coils shall feature factory-installed thermostatic expansion valves (TXVs) for refrigerant control. The TXVs shall be capable of external adjustment. Direct-expansion heat pump coils shall have a factory-installed bypass line and check valve assembly around the TXVs to allow liquid flow from the coil to the outdoor unit during the heating mode. Coil tubing shall be internally rifled to maximize heat transfer.
2. Chilled water coils shall be rated for an operating pressure of not less than 300 psig (2069 kPag).

C. Operating Characteristics:

Unit shall be capable of providing _____ cfm (L/s) airflow at an external static pressure of _____ in. wg (kPag).

D. Motor:

Fan motor of the size and electrical characteristics specified on the equipment schedule shall be factory supplied and installed.

Motors rated at 1.3 through 3.7 hp (0.97 through 2.76 kW) shall have internal thermal overload protection. Motors rated at 5, 7^{1/2}, and 10 hp (3.73, 5.60, and 7.46 kW) shall be protected by a circuit breaker.

E. Factory-Installed Options:

1. Alternate Motor and Drive:

An alternate motor and/or medium- or high-static drive shall be available to meet the airflow and external static pressure requirements specified on the equipment schedule.

F. Field-Installed Accessories (ordered from NAO):

1. Hot Water Coil:

Coil shall be 2-row, U-bend coil with copper tubes and aluminum plate fins bonded to the tubes by mechanical expansion. Coil shall be mounted in a galvanized steel housing that shall be fastened to the unit's fan deck for blow-thru heating operation. Coil shall have maximum working pressure of 150 psig (1034 kPag).

2. Steam Distributing Coil:

Coil shall consist of one row of copper tubes with aluminum plate fins, and shall have inner steam distributing tubes. Coil shall be mounted in a galvanized steel housing and shall be fastened to the unit's fan deck for blow-thru heating operation. Coil shall have maximum working pressure of 175 psig at 400 F (1207 kPag at 204.4 C).

3. Electric Heaters:

Heaters for nominal 240, 480, or 575-volt, 3-phase, 60 Hz; and 240, 400-volt, 3 phase, 50 Hz power supply shall be factory-supplied for field installation as shown on the equipment drawings. Electric heat assembly shall be ETL (U.S.A.) and ETL, Canada, agency approved, and shall have single-point power wiring. Heater assembly shall include contactors with 24-V coils, power wiring, 24-v control wiring terminal blocks, and a hinged access panel. Electric heaters shall not be used with air discharge plenum.

4. Air Discharge Plenum:

Plenum shall be factory supplied to provide free-blow air distribution for vertical floor-mounted units. A grille with moveable vanes for horizontal or vertical airflow adjustment shall be included. Plenum shall be field-assembled and field-installed on the unit's fan deck for blow-thru air distribution. Plenum shall not be used with electric heaters.

5. Return Air Grille:

Grille shall be factory supplied for field installation on the unit's return air opening.

6. Unit Subbase:

Subbase assembly shall be factory supplied for field installation. Subbase shall elevate floor-mounted vertical units to provide access for correct condensate drain connection.

7. Economizer:

Economizer for ventilation or "free" cooling shall be factory provided for field installation on either return air opening of air handler. For free cooling applications, economizer shall be compatible with separate thermostat; economizer dampers shall open when outdoor air enthalpy is suitable for free cooling. Economizer shall be compatible with separate CO₂ sensor accessory; economizer dampers shall open when indoor CO₂ level rises above predetermined setpoint. Economizer shall include enthalpy control and damper actuator.

8. Thermostat Controls:

- Debonair programmable multi-stage thermostat with 7-day clock, holiday scheduling, large Thermoglow^Y display, remote sensor capability, and Title 24 compliance.
- TEMP System programmable communicating multi-stage thermostat with fan switch, time clock, LCD display, ÉF/ÉC capability and CCN compatibility.
- Commercial Electronic Thermostat with 7-day time clock, auto-changeover, multi-stage capability, and large LCD temperature display.
- Non-programmable thermostat with fan switch subbase.

9. Overhead Suspension Package:

Package shall include necessary brackets to support units in a horizontal ceiling installation.

10. CO₂ Sensor:

Sensor shall provide the ability to signal the economizer to open when the space CO₂ level exceeds the predetermined set point. Sensor shall have the capability of being connected to Comfort System relay pack or to economizer using field-supplied and -installed Honeywell dc adapter no. Q769C1004.

11. Condensate Drain Trap:

Trap shall have transparent, serviceable design for easy cleaning. Kit shall include overflow shut-off switch and wiring harness for connection to an alarm if desired.

NOTES

NOTES



turn to the experts™ 

Manufacturer reserves the right to discontinue, or change at any time, specifications or designs without notice and without incurring obligations